

TM 9-4120-428-14

TECHNICAL MANUAL

**OPERATOR'S, UNIT, DIRECT SUPPORT, AND
GENERAL SUPPORT MAINTENANCE MANUAL**

FOR

**AIR CONDITIONER
HORIZONTAL, COMPACT, 9000 BTU/HR
208 VOLT, THREE PHASE, 400 HERTZ**

MODEL NO. F9000H-4SPFI

(NSN 4120-01-502-1319)

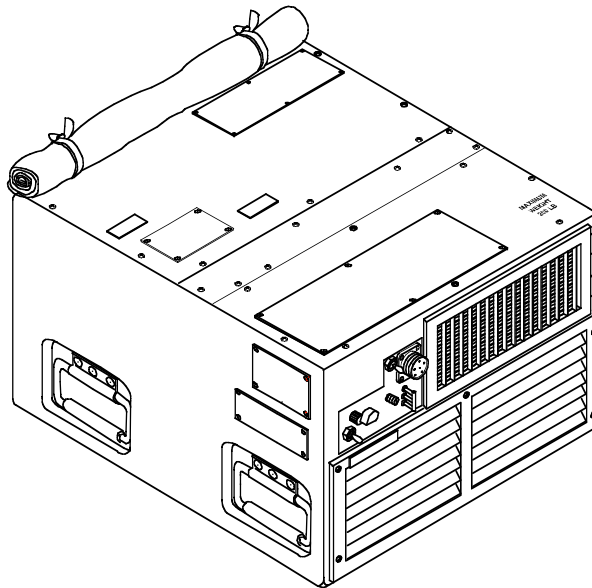

DISTRIBUTION STATEMENT A: Approved for public release; distribution is unlimited.

HEADQUARTERS, DEPARTMENT OF THE ARMY

1 OCTOBER 2003

WARNING SUMMARY

This warning summary contains general safety warnings and hazardous materials warnings that must be understood and applied during operation and maintenance of this equipment. Failure to observe these precautions could result in serious injury or death to personnel. Also included are explanations of safety and hazardous materials icons used within the technical manual.

EXPLANATION OF SAFETY WARNING ICONS



ELECTRICAL - electrical wire to hand with electricity symbol running through hand shows that shock hazard is present.



HEAVY OBJECT - human figure stooping over heavy object shows physical injury potential from improper lifting technique.

GENERAL SAFETY WARNINGS DESCRIPTION

WARNING



Whenever possible shut off system power before beginning work on equipment.

Do not come in contact with electrical connectors.

Don't be misled by low voltage.

Do not work on electrical equipment alone. Be sure another person is nearby who can give first aid.

WARNING



Some objects covered in this manual are heavy and need two soldiers to lift them.

EXPLANATION OF HAZARDOUS MATERIALS ICONS



CHEMICAL - drops of liquid on hand shows that the material will cause burns or irritation to human skin or tissue.



VAPOR - human figure in a cloud shows that material vapors present a danger to life or health.



FIRE - flame shows that a material may ignite and cause burns.



EYE PROTECTION - person with goggles shows that the material will injure the eyes.

HAZARDOUS MATERIALS DESCRIPTION

WARNING



DRYCLEANING SOLVENT P-D-680

P-D-680 solvent vapors are toxic. Avoid prolonged or repeated breathing of vapors or solvent contact with skin. Use only with adequate ventilation. Solvent is flammable and should not be used near open flame. Fire extinguishers should be readily available when solvent is used.

LIST OF EFFECTIVE PAGES/WORK PACKAGES

Date of issue for the original manual is: 1 Oct 2003

Original 1 Oct 2003

TOTAL NUMBER OF PAGES FOR FRONT AND REAR MATTER IS 18 AND TOTAL NUMBER OF WORK PACKAGES IS 94, CONSISTING OF THE FOLLOWING:

Page/WP No.	* Change No.	Page/WP No.	* Change No.	Page/WP No.	* Change No.
Cover	0	WP 0024 00 (2 pgs)	0	WP 0056 00 (2 pgs)	0
Warnings	0	WP 0025 00 (6 pgs)	0	WP 0057 00 (4 pgs)	0
I	0	WP 0026 00 (2 pgs)	0	WP 0058 00 (2 pgs)	0
WP 0001 00 (2 pgs)	0	WP 0027 00 (2 pgs)	0	WP 0059 00 (2 pgs)	0
Chp 1 title page	0	WP 0028 00 (2 pgs)	0	WP 0060 00 (4 pgs)	0
WP 0002 00 (6 pgs)	0	WP 0029 00 (4 pgs)	0	WP 0061 00 (2 pgs)	0
WP 0003 00 (4 pgs)	0	WP 0030 00 (2 pgs)	0	WP 0062 00 (2 pgs)	0
Chp 2 title page	0	WP 0031 00 (4 pgs)	0	WP 0063 00 (4 pgs)	0
WP 0004 00 (4 pgs)	0	WP 0032 00 (2 pgs)	0	WP 0064 00 (2 pgs)	0
WP 0005 00 (8 pgs)	0	WP 0033 00 (2 pgs)	0	WP 0065 00 (2 pgs)	0
WP 0006 00 (4 pgs)	0	WP 0034 00 (2 pgs)	0	WP 0066 00 (6 pgs)	0
Chp 3 title page	0	WP 0035 00 (2 pgs)	0	WP 0067 00 (2 pgs)	0
WP 0007 00 (4 pgs)	0	WP 0036 00 (2 pgs)	0	WP 0068 00 (2 pgs)	0
Chp 4 title page	0	WP 0037 00 (2 pgs)	0	WP 0069 00 (4 pgs)	0
WP 0008 00 (10 pgs)	0	WP 0038 00 (2 pgs)	0	WP 0070 00 (2 pgs)	0
Chp 5 title page	0	WP 0039 00 (2 pgs)	0	WP 0071 00 (2 pgs)	0
WP 0009 00 (6 pgs)	0	WP 0040 00 (2 pgs)	0	WP 0072 00 (2 pgs)	0
Chp 6 title page	0	WP 0041 00 (2 pgs)	0	WP 0073 00 (2 pgs)	0
WP 0010 00 (4 pgs)	0	WP 0042 00 (2 pgs)	0	WP 0074 00 (2 pgs)	0
WP 0011 00 (2 pgs)	0	WP 0043 00 (2 pgs)	0	WP 0075 00 (2 pgs)	0
WP 0012 00 (2 pgs)	0	WP 0044 00 (4 pgs)	0	WP 0076 00 (2 pgs)	0
Chp 7 title page	0	WP 0045 00 (2 pgs)	0	WP 0077 00 (2 pgs)	0
WP 0013 00 (14 pgs)	0	WP 0046 00 (4 pgs)	0	WP 0078 00 (2 pgs)	0
WP 0014 00 (8 pgs)	0	WP 0047 00 (4 pgs)	0	WP 0079 00 (2 pgs)	0
WP 0015 00 (2 pgs)	0	WP 0048 00 (2 pgs)	0	WP 0080 00 (2 pgs)	0
WP 0016 00 (2 pgs)	0	WP 0049 00 (2 pgs)	0	WP 0081 00 (2 pgs)	0
WP 0017 00 (2 pgs)	0	WP 0050 00 (2 pgs)	0	WP 0082 00 (2 pgs)	0
WP 0018 00 (2 pgs)	0	WP 0051 00 (2 pgs)	0	WP 0083 00 (2 pgs)	0
WP 0019 00 (2 pgs)	0	WP 0052 00 (2 pgs)	0	WP 0084 00 (2 pgs)	0
WP 0020 00 (2 pgs)	0	WP 0053 00 (2 pgs)	0	WP 0085 00 (4 pgs)	0
WP 0021 00 (2 pgs)	0	Chp 8 title page	0	WP 0086 00 (2 pgs)	0
WP 0022 00 (4 pgs)	0	WP 0054 00 (2 pgs)	0	Chp 9 title page	0
WP 0023 00 (2 pgs)	0	WP 0055 00 (2 pgs)	0	WP 0087 00 (2 pgs)	0

TM 9-4120-428-14

Page/WP No.	* Change No.	Page/WP No.	* Change No.	Page/WP No.	* Change No.
WP 0088 00 (2 pgs)	0	WP 0090 00 (2 pgs)	0	WP 0094 00 (2 pgs)	0
Chp 10 title page	0	WP 0091 00 (4 pgs)	0	Glossary	0
WP 0089 00 (16 pgs)	0	WP 0092 00 (4 pgs)	0	Index	0
Chp 11 title page	0	WP 0093 00 (2 pgs)	0		

*Zero in this column indicates an original page.

TECHNICAL MANUAL

**OPERATOR, UNIT, DIRECT SUPPORT,
AND GENERAL SUPPORT MAINTENANCE MANUAL**

**AIR CONDITIONER, 9,000 BTU
HORIZONTAL, COMPACT
208 V, 3 PH, 400HZ
F9000H-4SPFI
NSN 4120-01-502-1319**

REPORTING ERRORS AND RECOMMENDING IMPROVEMENTS

You can help improve this manual. If you find any mistakes, or if you know of a way to improve the procedures, please let us know. We'd prefer that you submit your recommended changes electronically, either by e-mail (AMSEL-LC-LEO-PUBS-CHG@mail1.monmouth.army.mil) or online (<http://edm.monmouth.army.mil/pubs/2028.html>). Alternatively, you may mail or fax your letter, DA Form 2028 (Recommended Changes to Publications and Blank Forms) or DA Form 2028-2 located in back of this manual to: Commander, US Army Communications-Electronics Command and Fort Monmouth, ATTN: AMSEL-LC-LEO-E-ED, Fort Monmouth, NJ 07703-5006. The fax number is 732-532-3421, DSN 992-3421.

For Air Force, submit AFTO Form 22 (Technical Order System Publication Improvement Report and Reply) in accordance with paragraph 6-5, Section VI, TO 00-5-1. Forward direct to prime ALC/MST.

For Navy, mail comments to the Commander, Space and Naval Warfare Systems Command, ATTN: SPAWAR 8122, Washington, DC 20363-5100.

Marine Corps units, submit NAVMC 10772 (Recommended Changes to Technical Publications) to: Commanding General, Marine Corps Logistics Base (Code 850), Albany, Georgia 31704-5000.

In any case, we will send you a reply.

TABLE OF CONTENTS

	<u>WP Sequence No.</u>
WARNING SUMMARY	
General Information.....	0001 00
CHAPTER 1. DESCRIPTION AND THEORY OF OPERATION	
Equipment Description and Data.....	0002 00
Theory of Operation, Cooling and Heating.....	0003 00
CHAPTER 2. OPERATOR INSTRUCTIONS	
Description and Use of Operator Controls and Indicators.....	0004 00
Operation Under Usual Conditions	0005 00
Operation Under Unusual Conditions	0006 00

CHAPTER 3. OPERATOR TROUBLESHOOTING PROCEDURES
 Troubleshooting Index and Operational Checkout and Troubleshooting Procedures..... 0007 00

CHAPTER 4. UNIT TROUBLESHOOTING PROCEDURES
 Troubleshooting Index and Operational Checkout and Troubleshooting Procedures..... 0008 00

CHAPTER 5. DIRECT SUPPORT TROUBLESHOOTING PROCEDURES
 Troubleshooting Index and Operational Checkout and Troubleshooting Procedures..... 0009 00

CHAPTER 6. OPERATOR MAINTENANCE INSTRUCTIONS
 Preventative Maintenance Checks and Services (PMCS) 0010 00
 Maintenance Items (Various)..... 0011 00
 Lubrication Instructions 0012 00

CHAPTER 7. UNIT MAINTENANCE INSTRUCTIONS
 Service Upon Receipt..... 0013 00
 Preventive Maintenance Checks and Services 0014 00
 Fabric Cover Removal, Cleaning and Installation 0015 00
 Top Panel Removal, Cleaning and Installation 0016 00
 Rear Screen and Guard Cleaning and Replacement 0017 00
 Return Air Louver and Air Filter Removal, Cleaning, Inspection, and Installation 0018 00
 Supply Air Louver Removal, Cleaning and Installation 0019 00
 Information Plates Inspection and Replacement..... 0020 00
 Mist Eliminator Replacement, Cleaning, and Inspection 0021 00
 Condenser Air Discharge Louver and Linkage Cleaning, Inspection, and Replacement 0022 00
 Fresh Air Damper and Actuator Cleaning and Inspection..... 0023 00
 Condensate Drain Inspection, Cleaning, and Replacement..... 0024 00
 Electrical Wiring Repair 0025 00
 Control Module Assembly Removal, Repair and Installation..... 0026 00
 Temperature Selector Switch S3 Removal, Inspection, and Testing, and Installation..... 0027 00
 Evaporator Fan Speed Toggle Switch (S2) Removal, Inspection, Testing, and Installation 0028 00
 Mode Selector Switch (S1) Removal, Inspection, Testing, and Installation 0029 00
 Compressor Circuit Breaker (CB1) Removal, Inspection, Testing, and Installation 0030 00
 Control Module Rotary Switch Relay Inspection, Removal, Testing, Repair, and Installation 0031 00
 Control Module Wiring Harness Inspection, Removal, Testing, Repair, and Installation..... 0032 00
 Junction Box Removal, Inspection, Repair, and Installation 0033 00
 Junction Box Wiring Harness Inspection, Removal, Testing, Repair, and Installation 0034 00
 Time Delay Relay K1 Testing, Inspection, Removal, and Installation..... 0035 00
 Phase Sequence Relay (K5) Testing and Replacement 0036 00
 Relays K2 and K3 Inspection, Testing, and Replacement..... 0037 00
 Relay K4 Inspection, Testing, and Replacement 0038 00
 Control Circuit Breaker CB2 Inspection, Testing, and Replacement 0039 00
 Miscellaneous Cables, Harnesses, and Terminal Boards Inspection, Testing, Repair, and Replacement..... 0040 00
 Rectifier CR1 and Capacitors (C1 and C2) Inspection, Testing, and Replacement 0041 00
 Transformer T1 Inspection and Replacement 0042 00
 Power Factor Improvement Assembly Testing, Removal, and Installation 0043 00
 Evaporator Fan, Motor, and Housing Cleaning, Inspection, Testing, Removal, Assembly, and Installation..... 0044 00
 Heater Thermostat (S6) Removal, Inspection, Testing, Replacement, and Installation..... 0045 00
 Heater Elements Inspection, Testing, Removal, Cleaning, Replacement, and Installation 0046 00
 Condenser Fan and Motor and Inspection, Testing, Removal, and Installation..... 0047 00
 Evaporator Coil Inspection and Cleaning 0048 00
 Solenoid Valve (Coil) Testing, Repair, Removal, and Installation..... 0049 00
 Low Pressure Cutout Switch (LPCO) Bypass Installation..... 0050 00
 Condenser Coil Inspection and Cleaning 0051 00
 Connectors Inspection and Replacement 0052 00
 Installation Hardware Inspection and Replacement 0053 00

CHAPTER 8. DIRECT SUPPORT MAINTENANCE INSTRUCTIONS

General Maintenance Instructions	0054 00
Top Panels Repair and Replacement	0055 00
Fresh Air Damper and Actuator Removal, Replacement, Installation, and Adjustment	0056 00
Condenser Fan and Housing Removal and Installation	0057 00
Screens, Guards, and Louvers Repair and Replacement	0058 00
Service Manifold Removal and Installation	0059 00
Discharging the Refrigerant System	0060 00
Purging the Refrigerant System	0061 00
Brazing, Debrazing, and Cleaning Procedures	0062 00
Flushing the Refrigerant System	0063 00
Leak Testing	0064 00
Evacuating the Refrigerant System	0065 00
Charging the Refrigerant System	0066 00
Refrigeration System Troubleshooting	0067 00
Overheating Checks	0068 00
Refrigerant Pressure Check	0069 00
Dehydrator (Filter/Drier) Replacement	0070 00
Evaporator Coil Replacement	0071 00
Expansion Valve (Primary) Replacement	0072 00
Expansion Valve (Quench)	0073 00
Solenoid Valve (L1) Replacement	0074 00
Solenoid Valve L2 Replacement	0075 00
Pressure Regulator Replacement	0076 00
Actuating Cylinder Replacement	0077 00
High Pressure Switch S4 Inspection, Testing, and Replacement	0078 00
Low Pressure Switch S5 Inspection, Testing, and Replacement	0079 00
Service (Charging) Valves	0080 00
Pressure Relief Valve Replacement	0081 00
Condenser Coil Replacement	0082 00
Liquid Indicator (Sight Glass) Replacement	0083 00
Receiver Replacement	0084 00
Compressor Testing, Removal, Repair, and Installation	0085 00
Tubing and Fitting Replacement	0086 00

CHAPTER 9. GENERAL SUPPORT MAINTENANCE INSTRUCTIONS

General Information	0087 00
Housing Repair and Replacement	0088 00

CHAPTER 10. OPERATOR'S, UNIT, DIRECT SUPPORT, GENERAL SUPPORT MAINTENANCE INSTRUCTIONS

Illustrated List of Manufactured Items	0089 00
--	---------

CHAPTER 11. SUPPORTING INFORMATION

References	0090 00
Introduction for Maintenance Allocation Chart (MAC)	0091 00
Maintenance Allocation Chart (MAC)	0092 00
Components of End Item (COEI) and Basic Issue Items (BII) List	0093 00
Expendable and Durable Supplies and Materials List	0094 00

OPERATOR'S, UNIT, DIRECT SUPPORT, AND GENERAL SUPPORT MAINTENANCE**AIR CONDITIONER, HORIZONTAL, COMPACT****(NSN 4120-01-502-1319)****GENERAL INFORMATION**

SCOPE

This technical manual contains instructions for operation and maintenance of the Keco model F9000H-4SPFI Compact Horizontal 9,000 BTU/HR 208 Volt 3 Phase 400 Hertz Air Conditioner. Operators, Unit, Direct Support, and General Support Maintenance. The air conditioner is used primarily to cool and heat an enclosed space (shelter). The unit covered by this manual is designed for cooling and heating air to a desired predetermined range and circulating the conditioned air to provide heating and cooling of equipment or personnel within the conditioned area.

MAINTENANCE FORMS, RECORDS, AND REPORTS

Department of the Army forms and procedures used for equipment maintenance will be those prescribed by (as applicable) DA Pam 738-750, Functional Users Manual for the Army Maintenance Management System (TAMMS); DA PAM 738-751, Functional Users Manual for the Army Maintenance Management Systems - Aviation (TAMMS-A); or AR 700-138, Army Logistics Readiness and Sustainability.

REPORTING EQUIPMENT IMPROVEMENT RECOMMENDATIONS (EIR)

If your air conditioner needs improvement, let us know. Send us an EIR. You, the user, are the only one who can tell us what you don't like about your equipment. Let us know why you don't like the design or performance. Put it on an SF 368 (Product Quality Deficiency Report). Mail it to:

Commander, US Army Communications
Electronics Command and Fort Monmouth
Attention: AMSEL-LC-LEO-D-CS-CFO
Fort Monmouth, New Jersey 07703 - 5006

We will send you a reply.

CORROSION PREVENTION AND CONTROL (CPC)

Corrosion Prevention and Control (CPC) of Army materiel is a continuing concern. It is important that any corrosion problems with this item be reported so that the problem can be corrected and improvements can be made to prevent problems in future items.

While corrosion is typically associated with rusting of metals, it can also include deterioration of other materials, such as rubber and plastic. Unusual cracking, softening, swelling, or breaking of these materials may be a corrosion problem.

If a corrosion problem is identified, it can be reported using SF 368, Product Quality Deficiency Report. Use of key words such as "corrosion," "rust," "deterioration," or "cracking" will ensure that the information is identified as a CPC problem.

The form should be submitted to the address specified in DA PAM 738-750, Functional Users Manual for the Army Maintenance Management System (TAMMS).

DESTRUCTION OF ARMY MATERIEL TO PREVENT ENEMY USE

Refer to TM 750-244-3 Procedures for Destruction of Equipment to Prevent Enemy Use, for information about destruction.

PREPARATION FOR STORAGE

See Work Package 0005 00, Preparation for Movement, for instruction covering short and long term storage of the air conditioner as well as shipping container specifications.

WARRANTY INFORMATION

The Keco Industries, Inc. Model F9000H-4SPFI is warranted for one year. The warranty starts on the date found in block 23 of DA Form 2408-9, Equipment Control Record. Report all defects to your supervisor, who will take appropriate action.

LIST OF ABBREVIATIONS/ACRONYMS

Abbreviation/Acronym	Description
----------------------	-------------

COMMON TOOLS AND EQUIPMENT

For authorized common tools and equipment, refer to the Modified Table of Organization and Equipment (MTOE), CTA 50-970, Expendable/Durable Items (Except: Medical, Class V, Repair Parts, and Heraldic Items), or CTA 8-100, Army Medical Department Expendable/Durable Items, as applicable to your unit.

SPECIAL TOOLS, TMDE, AND SUPPORT EQUIPMENT

Special tools, TMDE, and support equipment are listed in the Maintenance Allocation Chart (MAC) Work Package 0000 00 of this manual.

REPAIR PARTS

Repair parts are listed and illustrated in the repair parts and special tools list TM 9-4120-428-24P.

END OF WORK PACKAGE

CHAPTER 1.

DESCRIPTION AND THEORY OF OPERATION

OPERATOR'S, UNIT, DIRECT SUPPORT, AND GENERAL SUPPORT MAINTENANCE
AIR CONDITIONER, HORIZONTAL, COMPACT
(NSN 4120-01-502-1319)
EQUIPMENT DESCRIPTION AND DATA

EQUIPMENT CHARACTERISTICS, CAPABILITIES, AND FEATURES

The Keco Industries, Inc. model F9000H-4SPFI Air Conditioner is designed to circulate, filter, and cool or heat air in the room or enclosure in which it is installed. The air conditioner will control and maintain enclosure temperature for efficient operation of electronic equipment and personnel comfort over a wide range of weather conditions.

Table 1. Location and Description of Major Components.

ITEM	COMPONENT	DESCRIPTION
1	Fabric Cover	Protects back or exposed side of the unit during periods of shut down. Must be rolled up when operating in the cool mode or when fresh (outside) air is being used in any mode.
2	Conditioned Air Supply Louver	Provides directional control of conditioned air.
3	Conditioned (Evaporator) Air Fan	Draws the room or enclosure air in over the filter and blow it out over the evaporator and heaters to supply conditioned air. The speed is adjustable. See Item 16.
4	Temperature Selector (Thermostat) Sensing Bulb	Senses the temperature of the room or enclosure air as it is drawn back into the air conditioner. This bulb is part of the TEMPERATURE SELECTOR control (thermostat) that is located on the control panel module.
5	Conditioned Air Filter	Filters room or enclosure air as it is re-circulated.
6	Conditioned Air Fan Motor	Drives the conditioned air fan.
7	Return Air Louver with Filter Clamps	The re-circulated air from the room or enclosure is drawn in through this louver. The conditioned air filter, item 5, is mounted on clips on the inside of this louver.
8	Junction Box and Control Panel Module	Contains major unit controls. See items 9 thru 16 for a description of some of these controls.
9	Control Circuit Breaker	Protects control circuit.
10	Input Power Receptacle (Primary Location)	Connection point for main input power cable. See item 37 for Input Power Receptacle (Alternate Location).
11	Control Panel Module	Contains switches and controls for operating the air conditioner. See items 13, 14, 16, and 17 for a description of these switches and controls.
12	High Refrigerant Pressure Cutout Switch	This switch is factory set to shut the compressor off if the refrigerant discharge line pressure rises to 470 to 490 psig (33.04 to 34.45 kg/cm ²). Note: This switch must be reset by hand after the pressure drops to 320 psig (22.50 kg/cm ²)
13	Compressor Circuit Breaker	Protects the compressor.
14	Mode Selector Switch	Allows selection of unit operating mode.

ITEM	COMPONENT	DESCRIPTION
15	Low Refrigerant Pressure Cutout Switch	This switch is factory set to shut the compressor off if the refrigerant suction line pressure drops to 10 to 20 psig (0.703 to 1.406 kg/cm ²). This switch must be hand reset after the pressure rises above 40 psig (2.812 kg/cm ²).
16	Evaporator Fan Speed Switch	Allows selection of HIGH or LOW unit conditioned air (evaporator) fan speed.
17	Temperature Selector (Thermostat) Switch	This switch allows selection of the desired temperature while operating in the cool or heat modes.
18	Ground Connection Point	Shelter or van electrical ground connection point.
19	Condenser Discharge Air Louver Assembly	The actuating cylinder automatically controls this louver assembly.
20	Condenser Air Inlet Guard	This expanded metal screen protects the condenser from damage.
21	Fresh Air Ventilation Guard	Screens and filters fresh air entering the unit.
22	Relief Valve	This safety valve opens when the refrigerant discharge line pressure rises above 540 psig (37.97 kg/cm ²).
23	Charging Valve Refrigerant Suction Line	Provides a connection point for charging and checking suction line pressure.
24	Charging Valve Refrigerant Discharge Line	Provides a connection point for charging and checking discharge line pressure.
25	Solenoid Valve Pressure Equalizing	This valve is normally open when the compressor is NOT running to equalize the pressure at the suction and discharge sides of the compressor. It closes when the compressor starts.
26	Condenser Fan and Motor	This fan and motor draws outside air over the condenser coil to remove heat from the refrigerant passing through the tubes of the condenser coil.
27	Compressor	Consists of a reciprocating compressor driven by an electrical motor, hermetically sealed inside a steel container with a lifetime charge of oil. An external (crankcase) heater is attached to the lower part of the container. The purpose of the heater is to prevent possible damage to the compressor caused by liquid refrigerant accumulation in the crankcase during a period of shut down. The heater is connected directly to input power and is thermostatically controlled to prevent overheating.
28	Condenser Coil	Made up of interconnected parallel copper tubes retained in a series of multiple, closely spaced aluminum fins. This coil serves as a heat exchanger to remove the heat from the compressed refrigerant vapor so that it will condense into a liquid.
29	Dehydrator, Desiccant, Refrigerant (Filter/Drier)	Removes moisture and contaminants from the refrigerant.
30	Receiver	The receiver acts as a storage tank for the liquid refrigerant.

ITEM	COMPONENT	DESCRIPTION
31	Solenoid Value, Liquid Line	This valve is normally open when the compressor is NOT running and is thermostatically controlled during cooling cycles when operating in the COOL mode.
32	Pressure Regulating Valve	This valve regulates the suction pressure by re-circulating a part of the compressor discharge hot gas to the suction line when the suction pressure drops below a preset value. This action prevents frosting of the evaporator coil.
33	Expansion Valve	Meters refrigerant flow to the evaporator during cooling cycles when operating in the COOL mode.
34	Evaporator Coil	Similar in construction to the multiple tubes, finned condenser coil. This coil serves as a heat exchanger for the refrigerant to absorb heat from the room or enclosure air circulated through the evaporator section.
35	Heating Elements	Consists of two banks of heating elements. Only one bank operates in the LOW HEAT mode. Both banks operate in the HIGH HEAT mode. One bank shuts off when the thermostat is satisfied in both HIGH and LOW HEAT modes.
36	Mist Eliminator	The purpose of the mist eliminator is to trap droplets of condensed water from the evaporator, so that they will not be blown into the air-conditioned space.
37	Input Power Receptacle	This receptacle allows the user to power the unit air conditioner from the room or enclosure being conditioned. Unit modifications have to be made prior to use, see WP 0016.
38	Indicator, Sight, Liquid	The sight allows the user to visually inspect the condition of the refrigerant for charge and moisture content.
39	Actuating Cylinder	Adjusts the condenser discharge air louver assembly (19). The actuator reacts to the changes in refrigerant pressure caused by the operating mode of the air conditioner.

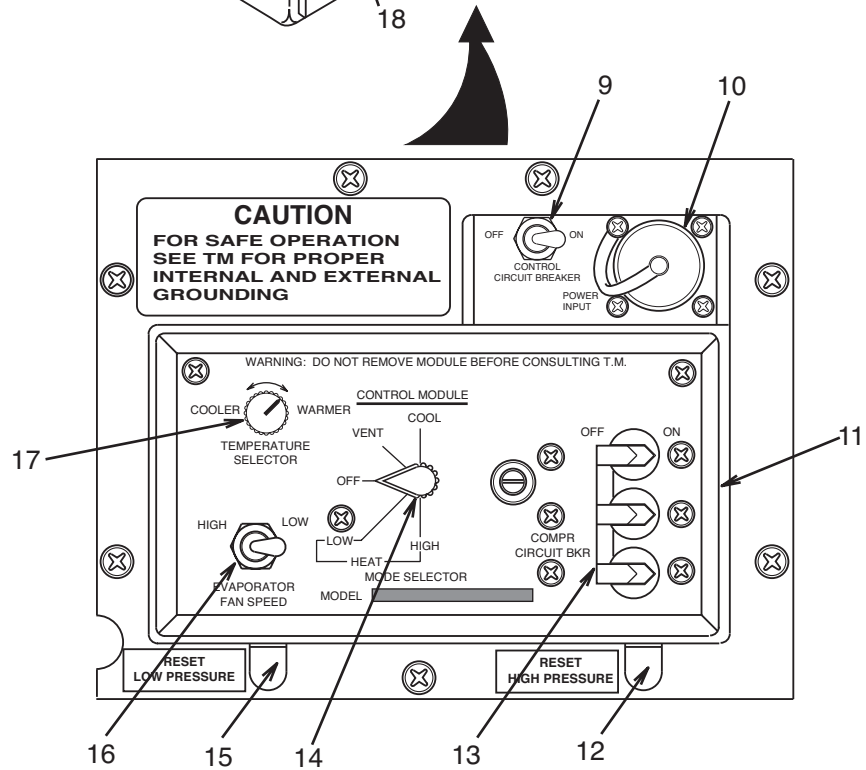
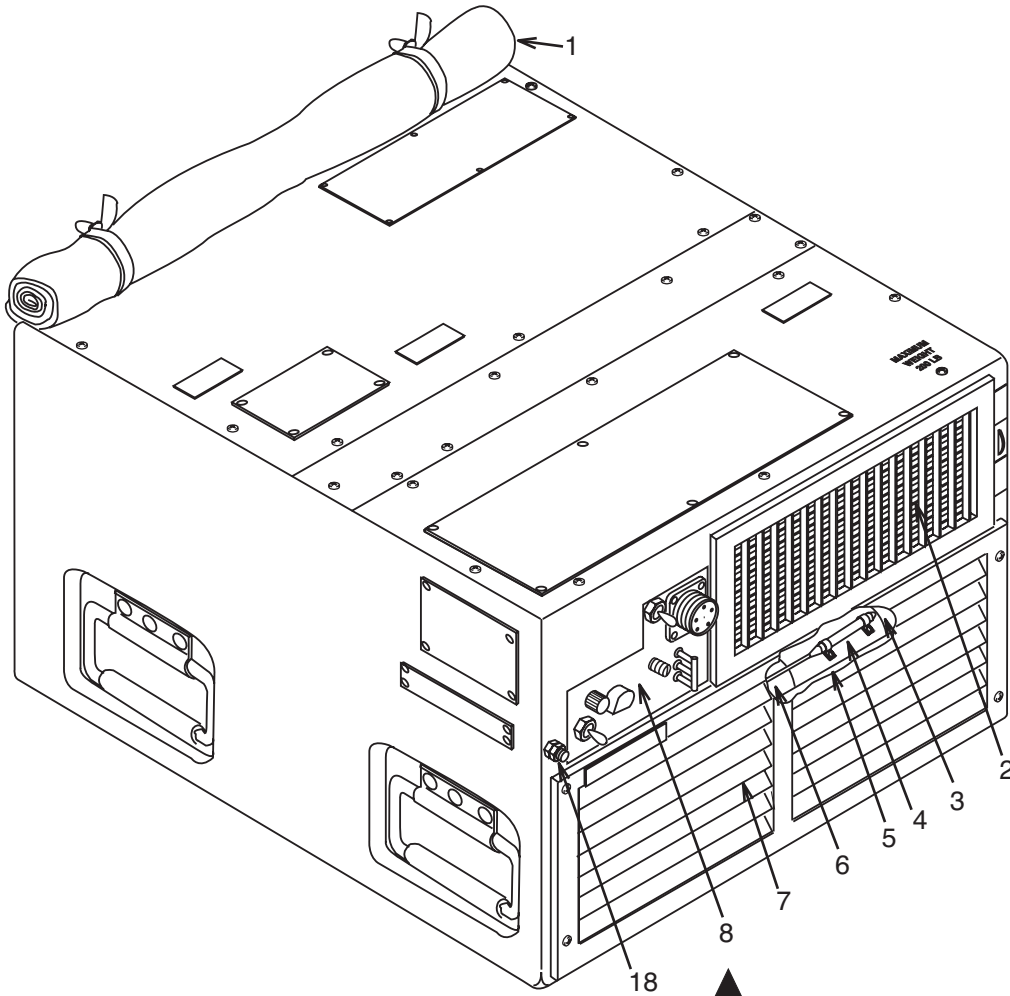

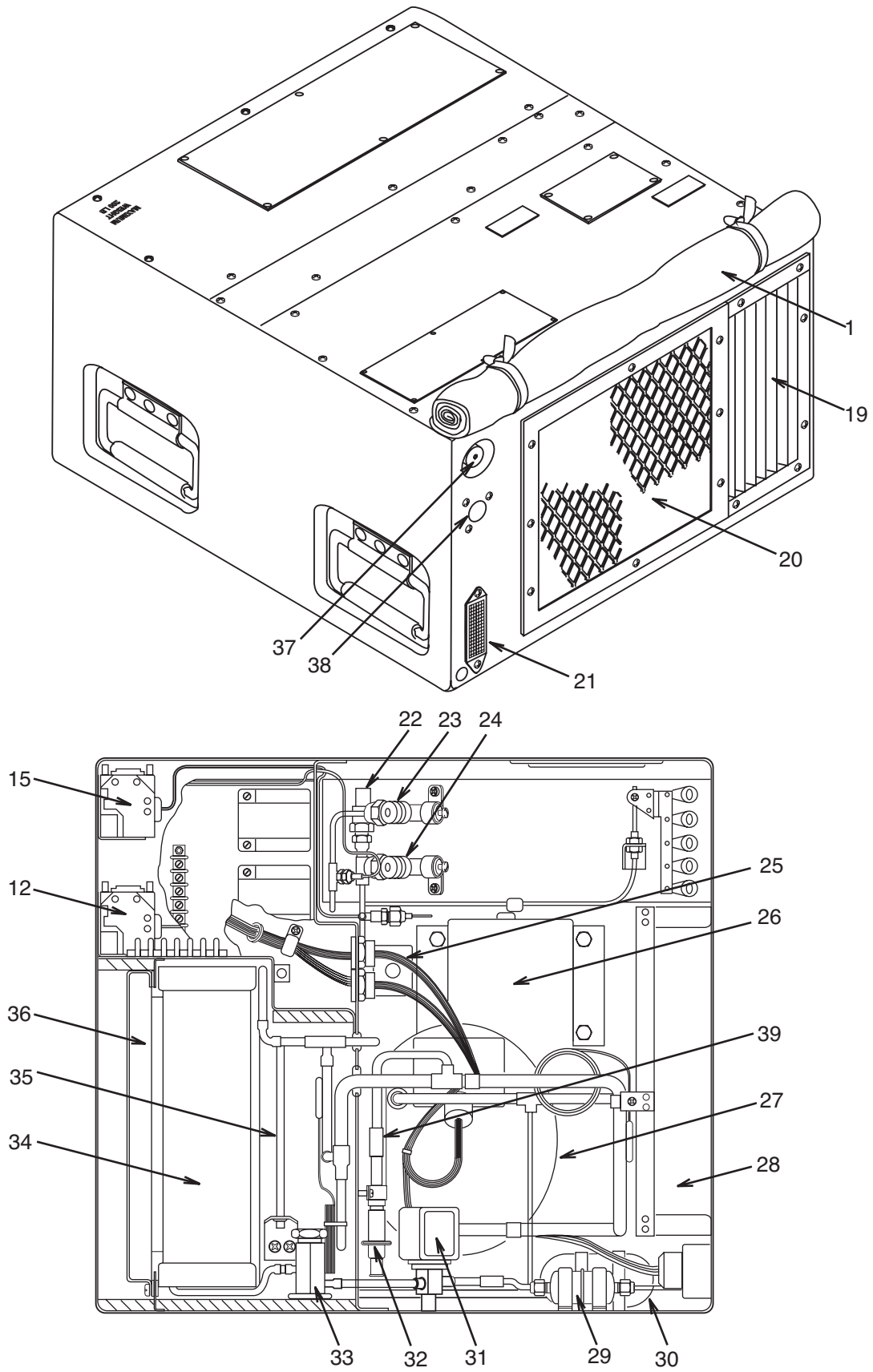

Table 2. Equipment Data.

Operating Temperature Range	Low -50°F (-45°C) High +120°F (+49°C)
Cooling Capacity	9,000 BTU/HR
Heating Capacity	7,000 BTU/HR
Phase	3 ph
Frequency	400 Hz
Voltage	208 Vac
Amperage	10 Amp
Wattage	4 kW
Refrigerant	R-22, 2.2 lbs. (1.0 kg)
Width	24.0 inches (60.96 cm)
Height	16 inches (40.64 cm)
Depth	26.5 inches (67.31 cm)
Weight	200 pounds (91.0 kg)

END OF WORK PACKAGE

OPERATOR'S, UNIT, DIRECT SUPPORT, AND GENERAL SUPPORT MAINTENANCE
AIR CONDITIONER, HORIZONTAL, COMPACT
(NSN 4120-01-502-1319)
THEORY OF OPERATION, COOLING AND HEATING

COOLING

The COMPRESSOR (1) takes cold, low-pressure refrigerant gas and compresses it to a high temperature, high pressure gas. This gas flows through the metal tubing to the CONDENSER COIL (3A) and (3B) and RECEIVER (4).

The condenser fan draws outside ambient air over and through the two section CONDENSER COIL (3A) and (3B). The high temperature, high-pressure gas from the COMPRESSOR (1) is cooled by the flow of air and is changed into a high-pressure liquid.

The LIQUID SIGHT GLASS (5) indicates the presence of moisture and quantity of refrigerant in the system.

The DEHYDRATOR, DESICCANT, REFRIGERANT (filter/drier) (6) removes any moisture (water vapor) or dirt that may be carried by the liquid refrigerant.

The SOLENOID VALVE (7) is controlled by the TEMPERATURE SELECTOR on the control panel. This valve will shut off the flow of refrigerant to the evaporator section when the temperature in the conditioned area reaches the set point.

The EXPANSION VALVE (8) controls the amount and pressure of liquid refrigerant to the EVAPORATOR COIL (9). The EXPANSION VALVE (8) senses the temperature and pressure of the refrigerant as it leaves the evaporator coil. By use of the sensing bulb, the valve constantly adjusts the flow of liquid refrigerant to the EVAPORATOR COIL (9). As the liquid refrigerant leaves the EXPANSION VALVE (8) it enters the EVAPORATOR COIL (9). As the liquid enters the coil at a reduced pressure, the reduction in pressure and the warmer air being forced across the tubes of the coil cause the refrigerant to boil or "flash" to a gas. The evaporator blower circulates the warm air from the conditioned space over and through the evaporator coil. Liquid absorbs heat when it changes from a liquid to a gas. As air from the conditioned spaces comes in contact with the EVAPORATOR COIL (9), the air is cooled.

To prevent compressor overload and damage during start-up, pressure equalizing SOLENOID VALVE (15) is closed at start of cooling cycle. This valve opens when compressor is not running to equalize pressure on both sides of compressor. b. Bypass System.

This unit has a bypass system, which allows cooling operation at low cooling loads without cycling the compressor on and off. In bypass the refrigerant is piped from the discharge to the suction side of the compressor, bypassing the EVAPORATOR COIL (9). When the TEMPERATURE SELECTOR on the control module senses that cooling conditions have reached the set point, it closes the SOLENOID VALVE (7) to shut off refrigerant flow to the EVAPORATOR COIL (9). As the compressor suction pressure starts to drop, the PRESSURE REGULATOR (10) opens to allow flow of hot gas from the compressor. The QUENCH VALVE (16) senses the temperature of the gas at the suction side of the compressor. To prevent excessively hot gas from reaching the compressor the QUENCH VALVE (16) opens to allow liquid refrigerant to mix with the hot gas.

The LINEAR ACTUATING CYLINDER ASSEMBLY (14) automatically controls the condenser discharge louver assembly.

The SERVICE VALVES (11) are provided for charging, and general servicing of the high and low- pressure sides of the refrigerant system.

The LOW PRESSURE SWITCH (17), the HIGH PRESSURE SWITCH (13) and the PRESSURE RELIEF VALVE (12) are provided to protect the unit from damage due to pressure extremes.

The flexible METAL HOSE ASSEMBLIES (2) and (18) provide vibration isolation between the compressor and other components of the refrigeration system.

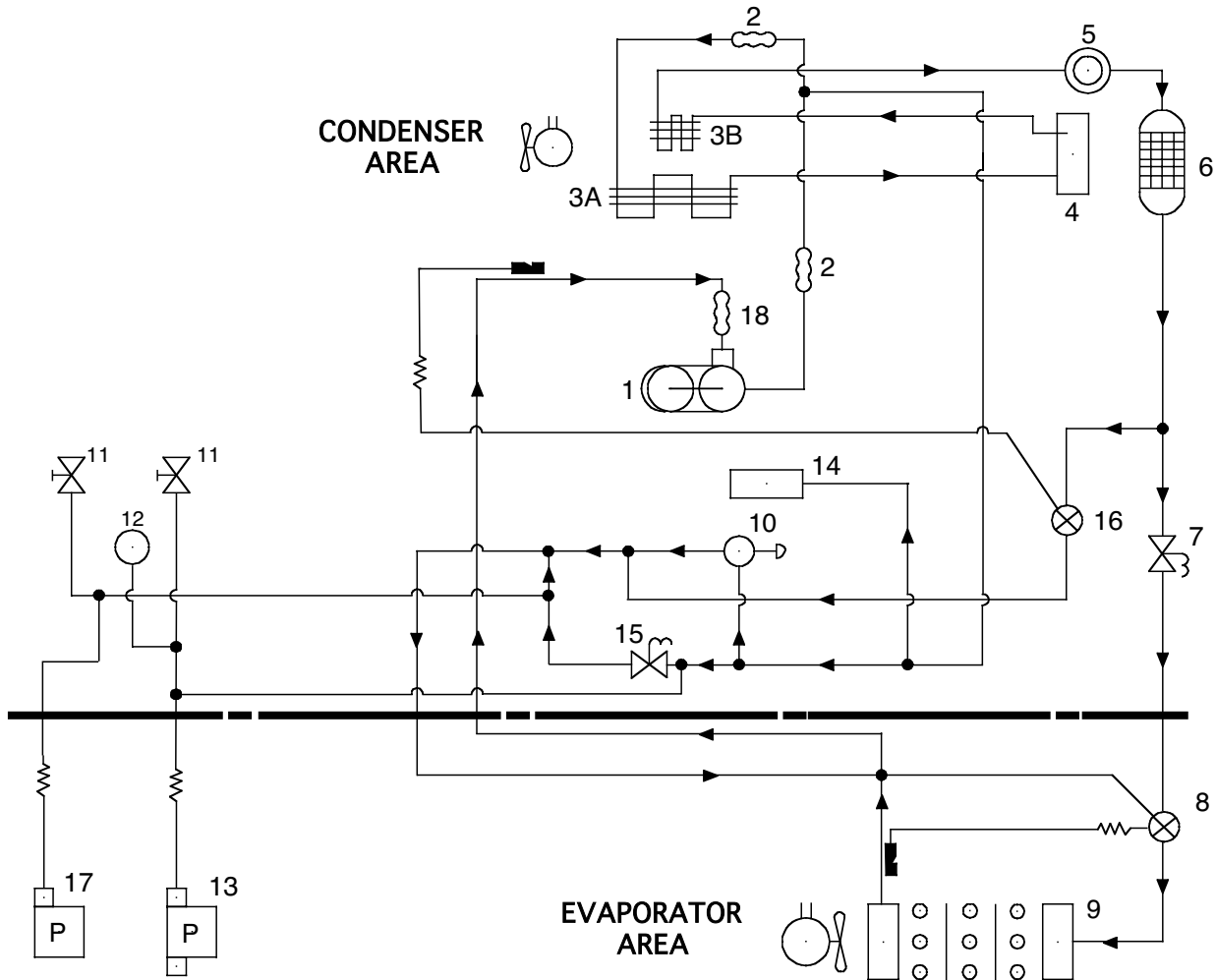

FIND NO.	QTY	NOMENCLATURE
1	1	COMPRESSOR, RECIPROCATING
2	2	HOSE ASSEMBLY, METAL
3A	1	COIL, CONDENSER WITH ANGLE
3B	1	SUB COOLER
4	1	RECEIVER, LIQUID REFRIGERANT
5	1	INDICATOR, SIGHT, LIQUID
6	1	DEHYDRATOR, DESICCANT, REFRIGERANT
7	1	SOLENOID VALVE WITH LEADS
8	1	VALVE, EXPANSION (PRIMARY)
9	1	COIL, EVAPORATOR
10	1	REGULATOR, FLUID PRESSURE
11	2	VALVE, SERVICE
12	1	VALVE, PRESSURE RELIEF
13	1	SWITCH, PRESSURE (HIGH)
14	1	CYLINDER ASSEMBLY, ACTUATING, LINEAR
15	1	SOLENOID VALVE WITH LEADS
16	1	VALVE, EXPANSION (QUENCH)
17	1	SWITCH, PRESSURE (LOW)
18	1	HOSE ASSEMBLY, METAL

HEATING

When the MODE SELECTOR is set for HIGH HEAT, all heating elements, located behind the evaporator coil can be energized. The TEMPERATURE SELECTOR thermostatically controls half of the elements. The remaining half is on all the time. When set for LOW HEAT, only the thermostatically controlled elements can be energized. All of the elements are protected from overheating by a thermal cutout switch

The two speed fan can be set for either HIGH or LOW operation during heating.

END OF WORK PACKAGE

CHAPTER 2.
OPERATOR INSTRUCTIONS

OPERATOR'S MAINTENANCE
AIR CONDITIONER, HORIZONTAL, COMPACT
(NSN 4120-01-502-1319)

DESCRIPTION AND USE OF OPERATOR CONTROLS AND INDICATORS

GENERAL

The Model F9000H-4SPFI air conditioner is designed for a wide variety of installations and for operation under a wide range of climatic conditions. It is designed for continuous or intermittent operation as a self-contained unit. Operator must be aware of any oddities or operational limitations for their specific installation.

Table 3. Operator's Controls and Indicators.

NAME	FUNCTION
Fresh Air Damper Control	Manually controls the position of the fresh air damper to allow more or less outside fresh air to mix with conditioned air.
Conditioned Air Supply Louver	Can be used to direct the flow of conditioned air in the shelter by positioning the individual louver blades.
Return Air Louver Assembly	Can be adjusted to control the amount of air being circulated in the shelter. For optimum performance, the louvers should be fully open.
Fabric Cover	When rolled down in the heating mode, it reduces heat loss from the shelter and minimizes dirt and debris from obstructing the condenser coil.
Mode Selector Switch	A rotary switch used to select the various modes of operation as necessary for shelter requirements or environmental conditions.
Evaporator Fan Speed Switch	A toggle switch used to select either of two fan speeds depending on shelter requirements.
Compressor Circuit Breaker	Provides compressor electrical circuits overload protection. Will automatically trip off if compressor current draw exceeds circuit breaker rating. If tripped, it must be manually reset.
Control Circuit Breaker	Provides control system electrical circuits overload protection. Will automatically trip off if any component in the control system current draw exceeds circuit breaker rating. If tripped, it must be manually reset.
Low Pressure Refrigerant Cutout Switch	Provides low-pressure operation protection. Will automatically trip open if low-pressure (suction) side of refrigerant system drops to switch setting. If tripped, it must be manually reset.
High Pressure Refrigerant Cutout Switch	Provides high-pressure operation protection. Will automatically trip open if high-pressure (discharge) side of refrigerant system rises to switch setting. If tripped, it must be manually reset.
Temperature Selector Switch	Allows the adjustment of air temperature leaving the air conditioner. Capable of adjusting temperature from 60 degrees F to 90 degrees F.
Refrigerant Sight Glass	Allows the operator to visually inspect the condition of the refrigerant, for charge and moisture content. If the refrigerant is milky in appearance and has frequently appearing bubbles, this is an indication of low refrigerant charge. A colored indicator, which is green, will turn greenish yellow to yellow when the moisture level in the refrigerant becomes or is unacceptable. IMPORTANT – if a low charge or high moisture content are suspected, contact direct support maintenance to take appropriate action.

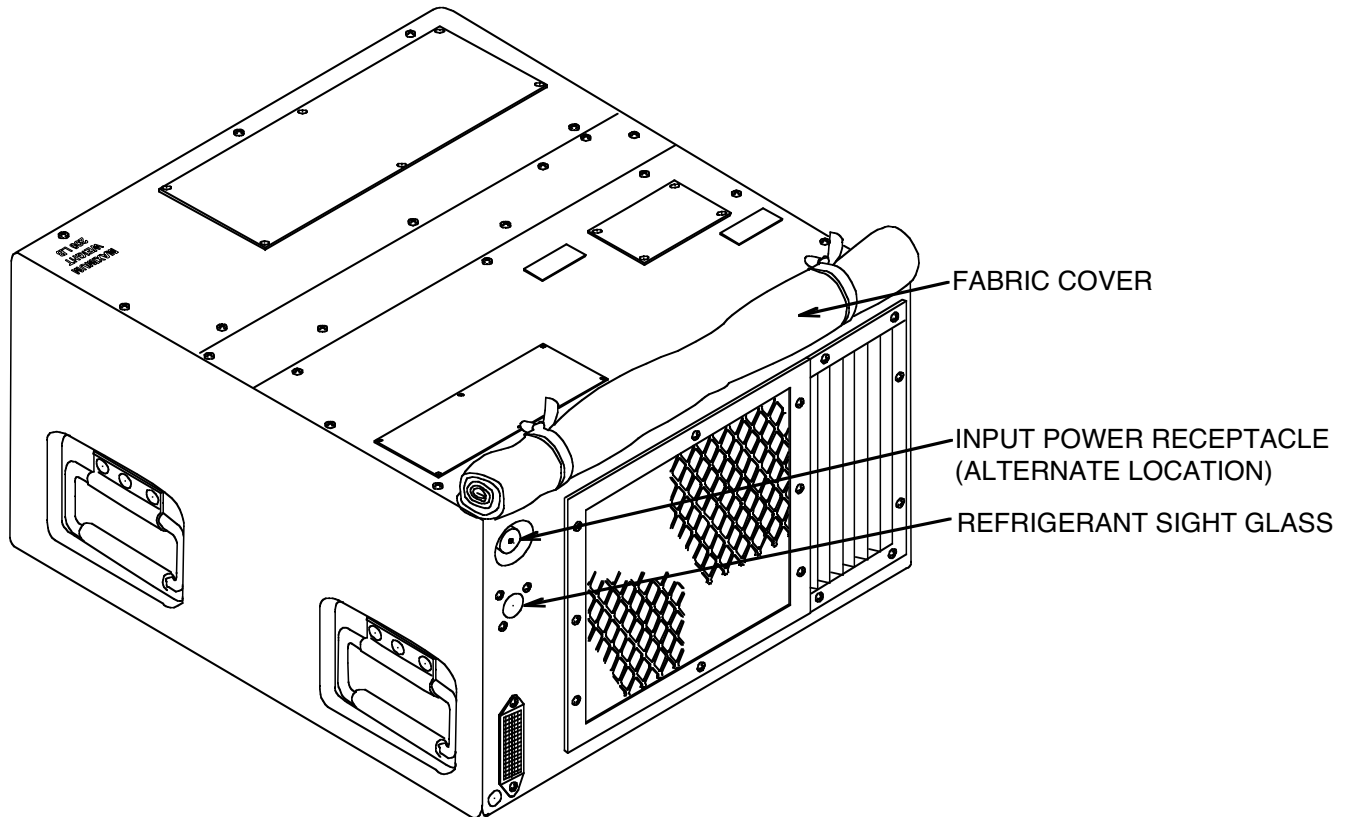
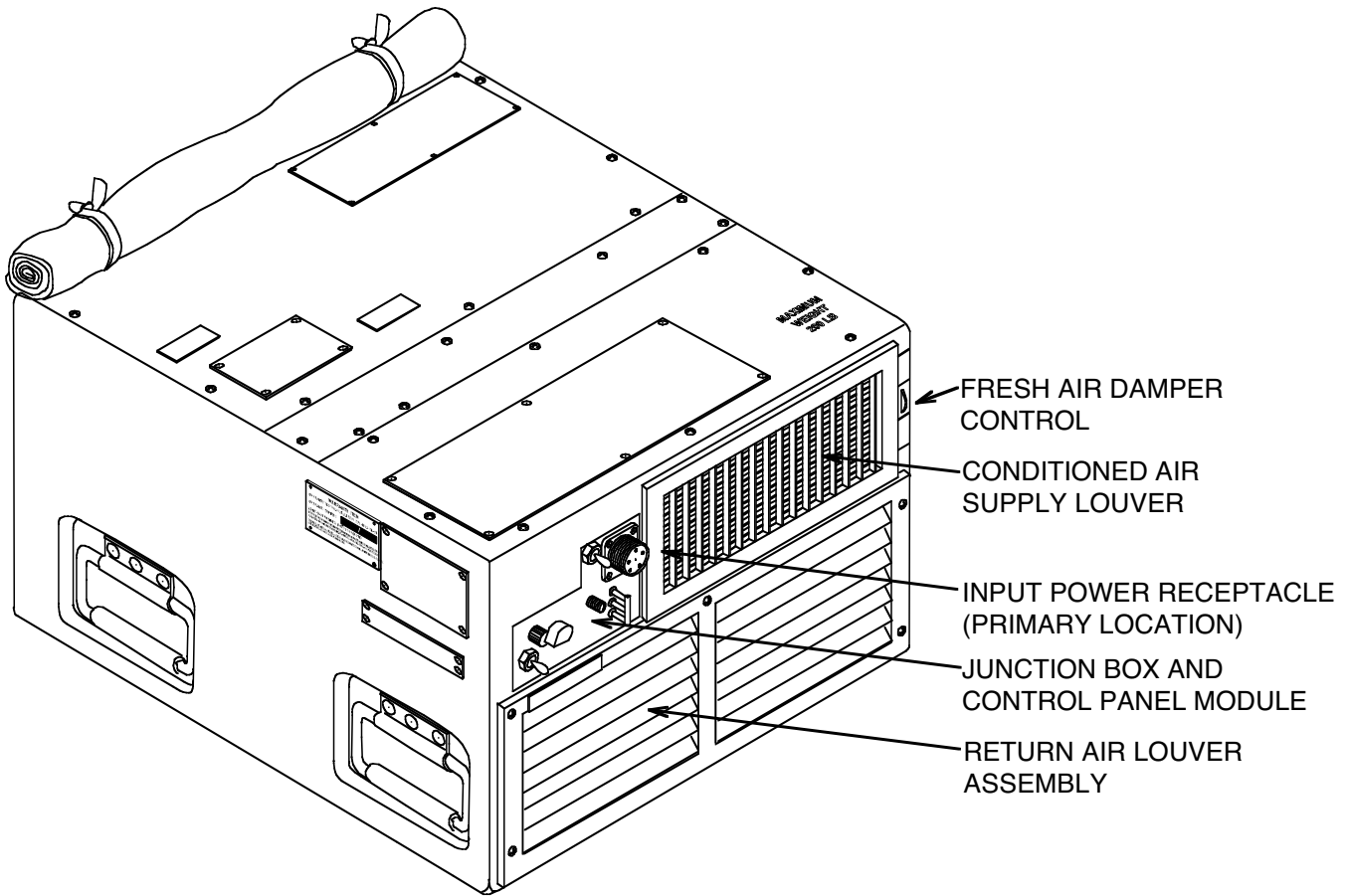

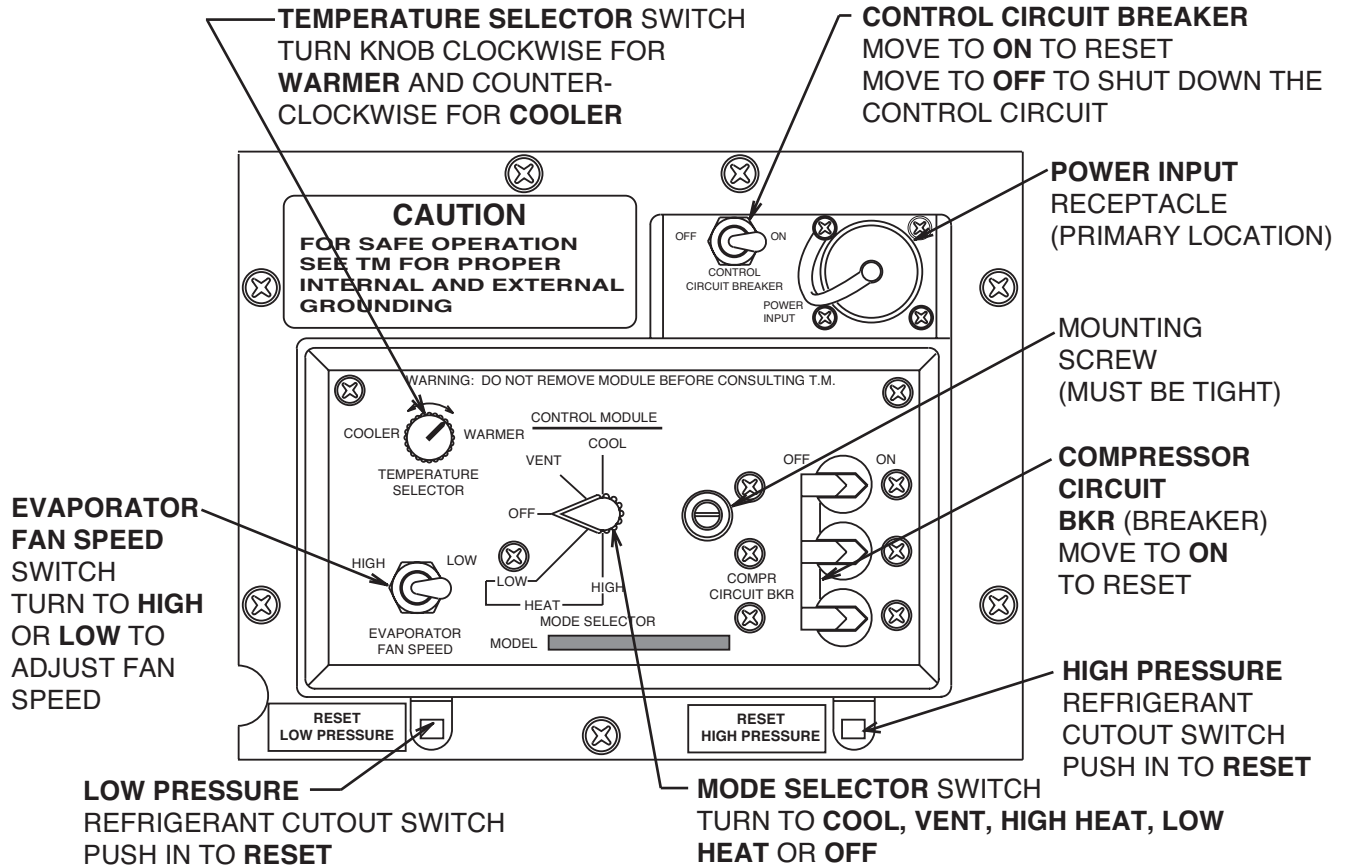

END OF WORK PACKAGE

OPERATOR'S MAINTENANCE
AIR CONDITIONER, HORIZONTAL, COMPACT
(NSN 4120-01-502-1319)
OPERATION UNDER USUAL CONDITIONS

ASSEMBLY AND PREPARATION FOR USE

The Model F9000H-4SPFI air conditioner is completely assembled and self-contained as received. No specific operator preparation for use is required once the unit is in place.

CAUTION

Do not operate the air conditioner immediately after power has been connected. The compressor can be damaged by liquid refrigerant that may have migrated to it. The compressor crankcase heater boils the liquid refrigerant out of the compressor. Power must be connected for at least four hours in moderate climate conditions and at least eight hours in sub-freezing climate conditions.

OPERATIONAL CHECKS

The air conditioner should be checked for operation in each mode after installation is completed and when it is placed back in operation after an extended shut down period.

NOTE

The fresh air damper should be positioned fully closed whenever the fabric cover is rolled down and secured since outside air cannot be drawn in through the fresh air inlet screen.

STARTING AND OPERATING INSTRUCTIONS FOR COOLING

1. Roll up and tie the fabric cover on the back of the cabinet. Secure it in place with two straps.

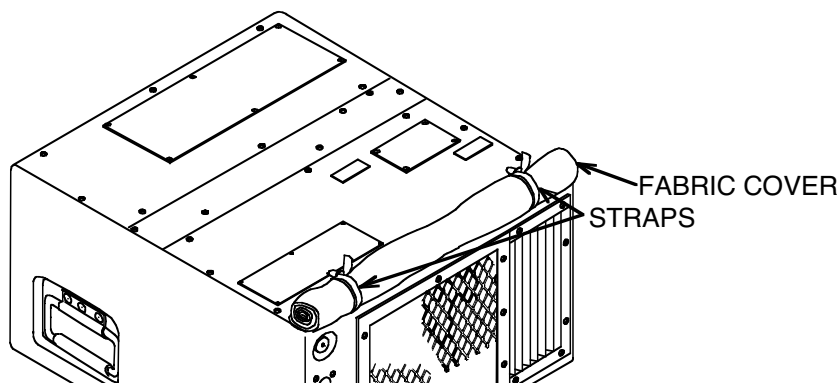

2. Individually adjust all louvers in conditioned air supply louver assembly to the fully open (horizontal) position.
3. Use the operating levers to adjust the louvers in both sections of the return air louver assembly to the fully open position.
4. Turn the fresh air damper control to the fully closed (up) position.
5. Check that the Mode Selector Switch is set to OFF.
6. Turn both circuit breaker switches to OFF.
7. Remove condensate drain for the lower left backside of the unit.

Starting And Operating Instructions For Cooling - Continued

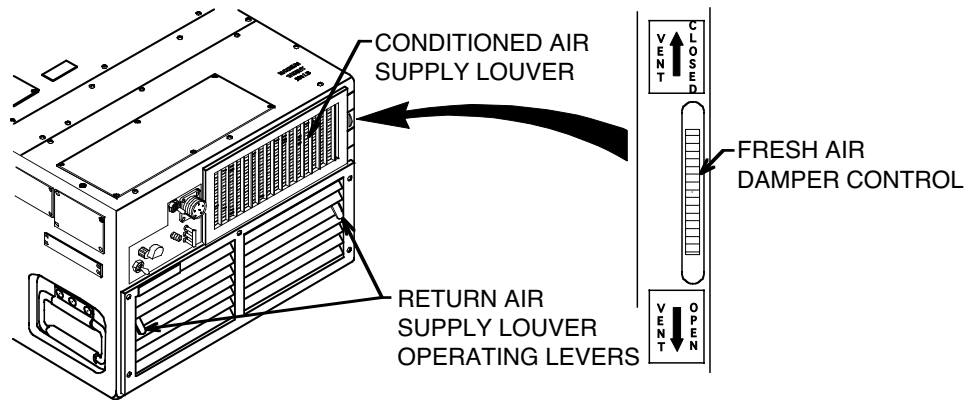

8. Check that the air conditioner is connected to the proper power source (208 volts, 3 phase, 400 hertz) and is properly grounded through a wire connected to the grounding stud at the lower-left corner of the control module. Power must be connected for at least four hours prior to operation (eight hours in sub-freezing climates). Notify Unit Maintenance if you cannot confirm this.

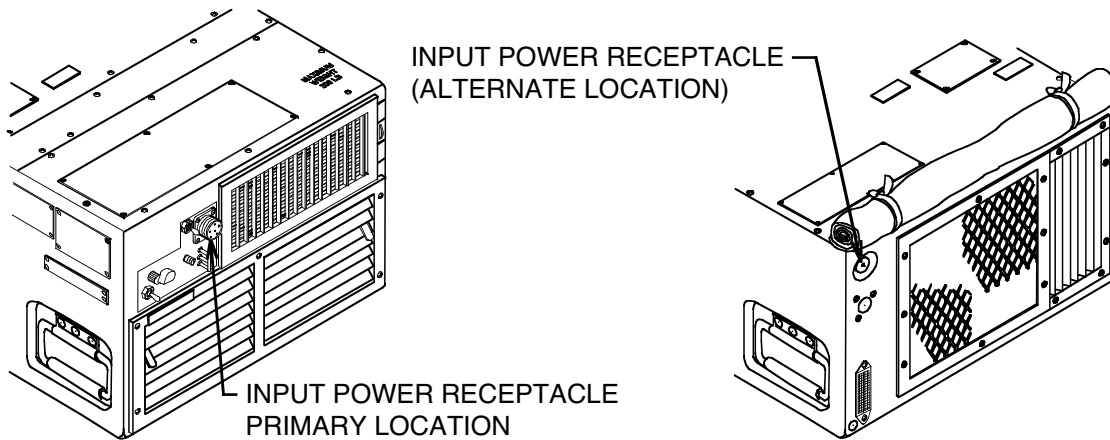

9. Turn the temperature selector switch to WARMER.
10. Position the CONTROL CIRCUIT BREAKER and the COMPRESSOR CIRCUIT BREAKER to "ON."
11. Turn the MODE SELECTOR switch to VENT (ventilate). The evaporator fan should start immediately. Use a paper streamer, or other method, to check the airflow into the return air louver and out of the conditioned air supply louver. Test the EVAPORATOR FAN SPEED switch at both the HIGH and the LOW speed settings. There should be noticeably more airflow at the HIGH-speed setting than at the LOW speed setting.

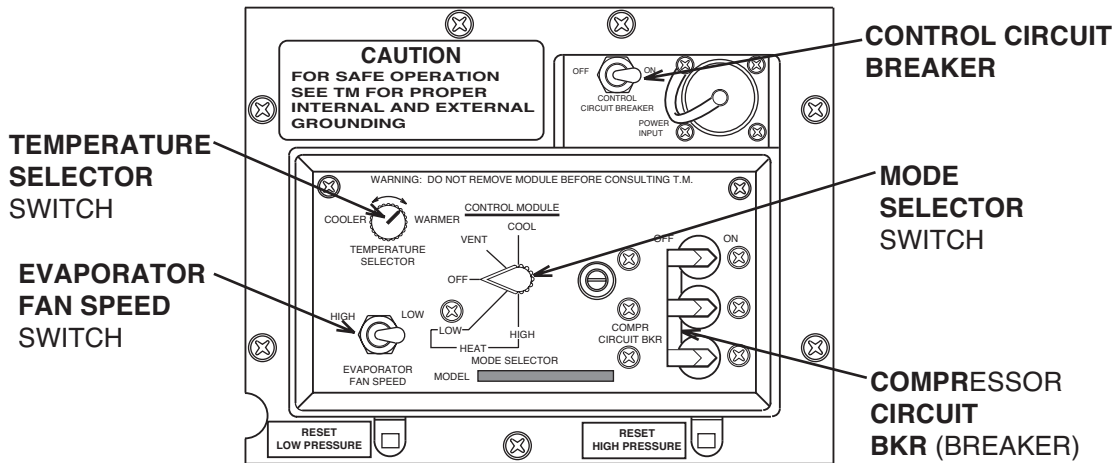
Starting And Operating Instructions For Cooling - Continued

12. Check for maximum ventilation with fresh air by turning the fresh air damper control wheel to open (down), and then adjust the blades in the return air louver to close them. Check the fresh air inlet located on the lower left corner of the back of the unit using a paper streamer or other method to be sure that air is being drawn in.

NOTE

To maximize the introduction of fresh air into the shelter, a door or window must be opened slightly to prevent an overpressure condition that would restrict airflow.

The TEMPERATURE SELECTOR (thermostat) control has an effective functional range between 60°F and 90°F (16°C and 32°C).

13. Turn the TEMPERATURE SELECTOR (thermostat) knob to the full WARMER (clockwise) position and then turn the MODE SELECTOR switch to LOW HEAT. Place your hand in the airflow from the conditioned air supply louver and feel for a temperature rise. When the supply air temperature has reached a relatively stable level, turn the MODE SELECTOR switch to HIGH HEAT and feel for a further temperature rise. Next, turn the TEMPERATURE SELECTOR thermostat control knob to the fully COOLER (counterclockwise) position. Feel that supply air temperature drops to approximately the same relatively stable level previously noted in LOW HEAT. Finally, turn the MODE SELECTOR switch to LOW HEAT and feel the discharge air temperature drop to ambient level (room temperature).

CAUTION

If a knocking or pounding noise is heard when the compressor starts, immediately turn the MODE SELECTOR out of the COOL position. Leave input power connected and wait at least two hours before attempting another start in COOL mode.

14. Turn the TEMPERATURE SELECTOR control knob to the WARMER (clockwise) position, then turn the MODE SELECTOR switch to COOL. Note that the evaporator and condenser fans start immediately and that the compressor starts approximately 30 seconds later. Hold your hand in the airflow from the conditioned air supply louver; there should be no change in temperature. Now turn the TEMPERATURE SELECTOR control knob to the COOLER (counterclockwise) position and feel the supply air temperature begin to drop almost immediately. Leave controls in the present position and perform the next check.

CAUTION

Do not operate the air conditioner in the COOL mode if the sight glass has numerous bubbles going through it or if the indicator color is yellow.

15. After 15 minutes of operation, check the sight glass to determine the refrigerant condition. If the liquid refrigerant observed in the sight glass has a milky appearance or frequent bubbles appear, the volume of refrigerant could be low and the system may need to be charged. The sight glass contains an indicator that is sensitive to water moisture. This

indicator changes color in response to the amount of water moisture that may be contained in the refrigerant. Excessive moisture in the refrigerant may damage or possibly destroy the compressor. If no moisture is present, the indicator will be green. If the moisture content becomes undesirable, the indicator will be greenish yellow. If the moisture content becomes unacceptable, the indicator will be yellow. If a low charge or unacceptable moisture level is indicated, contact direct support maintenance to take appropriate action.

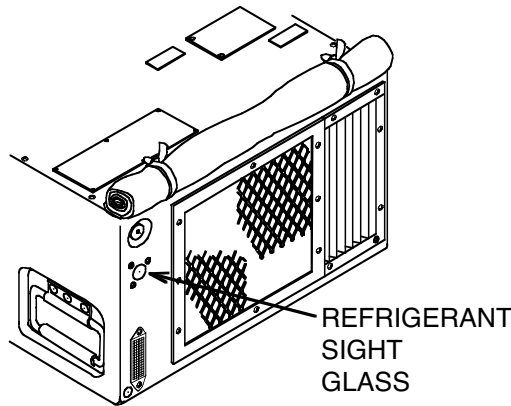

16. Turn the MODE SELECTOR switch to OFF. Observe that all air conditioner functions cease.

GENERAL OPERATING PROCEDURES

The Model F9000H-4SPFI air conditioner is designed for operation in a wide range of climatic conditions either continuously or intermittently. The amount of operator attention required will vary depending on specific local conditions for each installation. Under usual conditions, the air conditioner will be set up for the appropriate mode of operation at the beginning of a season and will only need starting, stopping, and minor adjustments for the rest of the season. The following table provides the recommended initial control settings to establish the desired mode of operation. Minor adjustments may be required to obtain the desired shelter temperature and mixture of re-circulated to fresh air or the airflow patterns of conditioned air inside the shelter.

Table 1. Initial Operator Control Settings.

MODE	MODE SELECTOR	TEMPERATURE SELECTOR	FRESH AIR DAMPER	RETURN AIR LOUVER	CONDITIONED AIR SUPPLY LOUVER	FABRIC COVER
Ventilation with 100% Recirculated Air	VENT	Any Setting	Fully Closed	Fully Open	Optional	Optional
Ventilation with Make-up Fresh Air	VENT	Any Setting	Partially Open	Partially Closed	Optional	Rolled Up
Ventilation with 100% Fresh Air	VENT	Any Setting	Fully Open	Fully Closed	Optional	Rolled Up
Heating with 100% Recirculated Air	LOW or HIGH HEAT	Desired Temperature	Fully Closed	Fully Open	Slightly Upward	Optional
Heating with Make-up Fresh Air	LOW or HIGH HEAT	Desired Temperature	Partially or Fully Closed	Partially or Fully Closed	Slightly Upward	Rolled Up
Cooling with 100% Recirculated Air	COOL	Desired Temperature	Fully Closed	Fully Open	Slightly Upward	Rolled Up
Cooling with Make-up Fresh Air	COOL	Desired Temperature	Partially or Fully Closed	Partially or Fully Closed	Slightly Upward	Rolled Up

OPERATION IN VENTILATION MODE

1. Roll up and tie the canvas cover.
2. Open evaporator discharge louvers.
3. Turn the ventilation damper actuator to open the damper door.
4. Partially close the evaporator intake louver blades.
5. Position the mode selector switch to VENT.

OPERATION IN HEATING MODE

1. Open the evaporator intake louver by moving the blades up or down as required.
2. Open the evaporator discharge louvers.
3. Turn the ventilation damper actuator to close the damper door.
4. Turn the temperature selector switch to the center position.
5. Position main circuit breaker to ON.
6. Position the mode selector switch to LOW HEAT.

NOTE

In LOW HEAT mode, three heaters will cycle on and off as determined by the temperature selector switch. In HIGH HEAT mode, three heaters will be on continuously and three will cycle on and off as determined by the temperature selector switch.

7. Operate in LOW HEAT mode until the temperature selector switch cycles the heaters off indicating that the set point has been reached. If the temperature does not increase to the set point, position the mode selector switch to HIGH HEAT.
8. When the temperature selector switch begins cycling the heaters, make any necessary adjustment to it until the desired shelter temperature is maintained. Allow sufficient time for the heaters to cycle off and on between adjustments.

NOTE

Warm air is less dense than cool air, so it has a tendency to rise. To obtain comfortable temperatures near the floor and lower parts of the room, it is often advisable to adjust the evaporator discharge louver blades to direct the air slightly downward.

9. Adjust the evaporator discharge louver blades to direct the airflow as desired.

OPERATION IN COOLING MODE

1. Open the evaporator intake louver by moving the blades up or down as required.
2. Open the evaporator discharge louvers.
3. Turn the ventilation damper actuator to close the damper door.
4. Turn the temperature selector switch to the center position.
5. Position main circuit breaker to ON.
6. Position the mode selector switch to COOL.

*Operation in Cooling Mode - Continued***NOTE**

The compressor operates on a 30 second time delay and will not come on with the fan and blower motors.

The compressor will operate continuously when in the cool mode. A refrigerant bypass circuit is activated to direct refrigerant around the evaporator coil when the temperature selector switch cycles off.

7. Operate the air conditioner until the temperature selector switch cycles the bypass circuit indicating that the set point has been reached.
8. When the temperature selector switch begins cycling the bypass circuit, make any necessary adjustment to it until the desired shelter temperature is maintained. Allow sufficient time for the bypass circuit to cycle off and on between adjustments.

NOTE

Cold air is denser than warm air, so it has a tendency to fall. To obtain comfortable temperatures near the upper parts of the room, it is often advisable to adjust the evaporator discharge louver blades to direct the air slightly upward.

9. Adjust the evaporator discharge louver blades to direct the airflow as desired.

OPERATION WITH FRESH AIR

1. Roll up and tie canvas cover if it is rolled down and secured.
2. Open the damper door by turning the ventilation damper actuator.
3. Partially close the evaporator intake louver blades.

STOPPING THE AIR CONDITIONER

1. Position the mode selector switch to OFF.
2. Close the evaporator intake louver blades by pushing tabs down.
3. Close the ventilation damper by turning the ventilation damper actuator.
4. If a shutdown is to be for an extended period, cover condenser side of unit with canvas cover and disconnect the power cable.
5. If unit is to be moved, notify unit maintenance to disconnect power and configure for transport.

DECALS AND IDENTIFICATION PLATES

A number of identification plates are provided on the exterior of the air conditioner cabinet. These plates are located on, or adjacent to, the control or device to which they apply. Refer to the following list and illustration for each identification plate location.

High-Pressure Charging Valve Decal	Locates charging valve.
Low-Pressure Charging Valve Decal	Locates charging valve.
Refrigeration Fluid Diagram Plate	Indicates refrigeration components.
Schematic Diagram	Indicates electrical components and wiring.
Vent Closed Decal	Indicates fresh air vent position.
Vent Open Decal	Indicates fresh air vent position.
Power Input Connector Plate	Locates input power connection.
CAUTION Grounding Decal	Grounding stud information.
Reset High Pressure Decal	Indicates location of high-pressure reset control.
Cold Weather Operation Decal	Indicates instructions for condenser louver adjustments for cold weather operation.
Danger Plate	Warning instructions.
Reset Low Pressure Decal	Indicates location of low-pressure reset control.
Military Unit ID Plate	Indicates military model and Serial Number.
Air Filter Access	Indicates location of air filter
Electrical Schematic Diagram Plate	Indicates location of electrical schematics

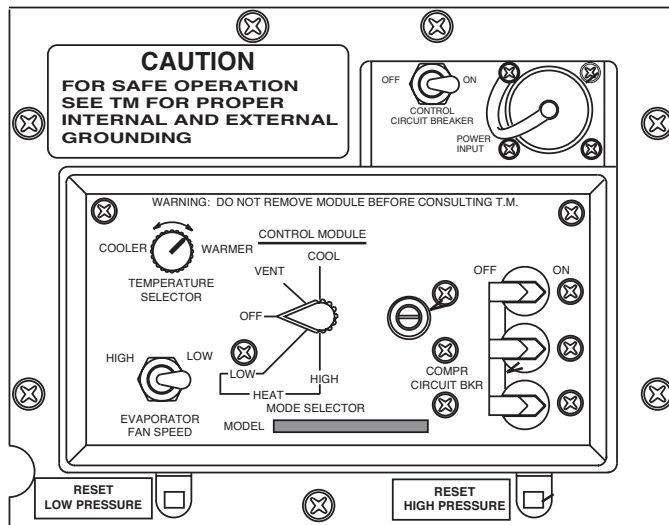
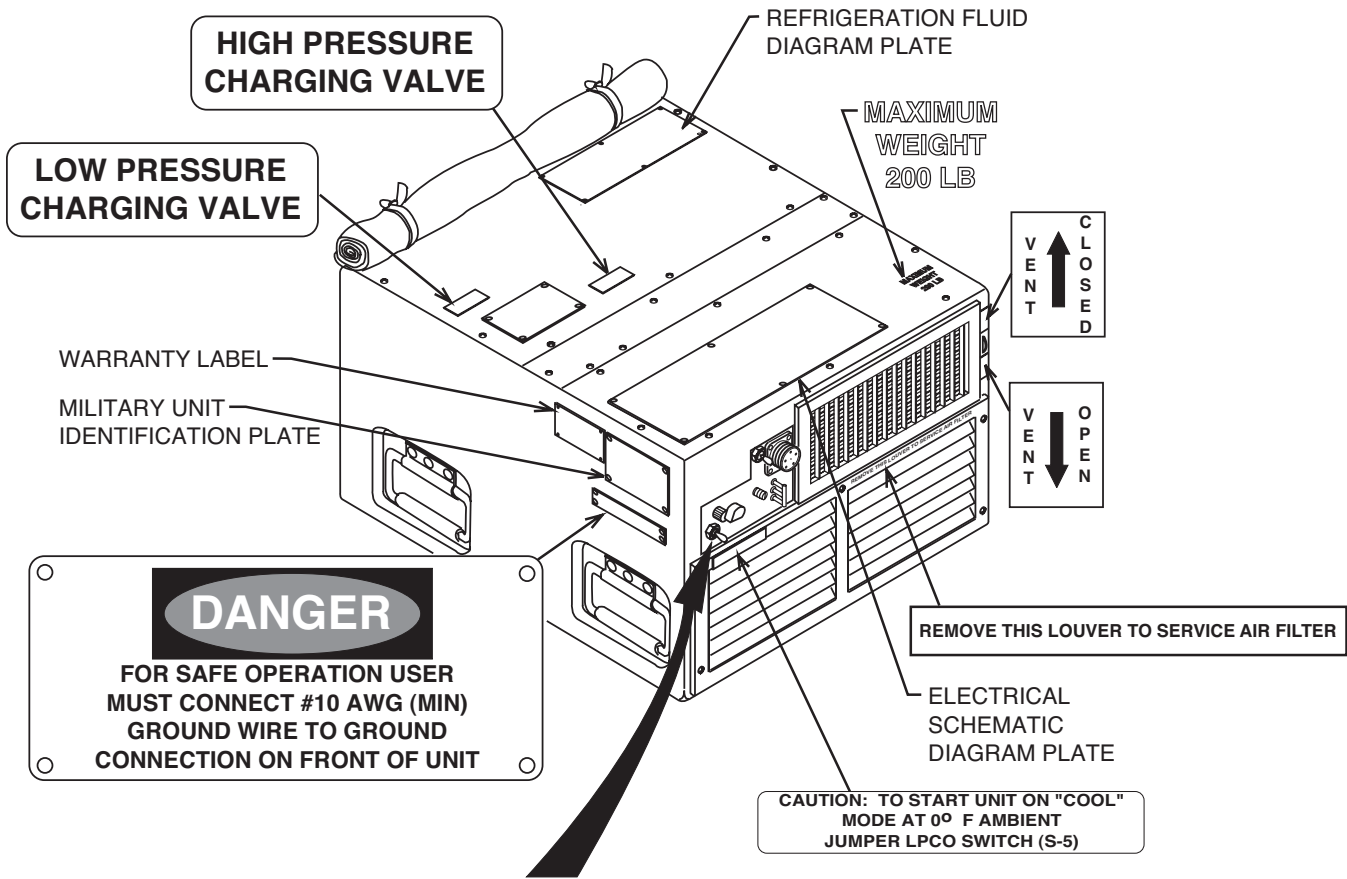

PREPARATION FOR MOVEMENT

Follow appropriate shutdown and PMCS procedures, and then consult further organizational requirements.

END OF WORK PACKAGE

OPERATOR'S MAINTENANCE
AIR CONDITIONER, HORIZONTAL, COMPACT
(NSN 4120-01-502-1319)
OPERATION UNDER UNUSUAL CONDITIONS

GENERAL

The Keco model F9000H-4SPFI air conditioners are designed for operation in a wide range of climatic conditions. However, some extreme conditions require special operating and servicing procedures to prevent un-due loading and excessive wear on the equipment.

CAUTION

Prior to operation ensure that the condenser louver in the rear of the unit is closed when the outside ambient temperature falls below +50°F (+10°C).

Before Operation

Before starting operation, be sure canvas cover is rolled up and secured. Clear all ice and snow from openings. Be sure all dampers are in operating condition.

After Operation

Roll down and snap on canvas cover over condenser intake and outlet.

CAUTION

Do not disturb wiring during cold weather unless absolutely necessary. Cold temperatures make wiring and insulation brittle and easily broken.

NOTE

The fabric cover must be rolled up when operating in the cooling mode. The fabric cover may be rolled down and snapped in place during other modes of operation as appropriate for environmental conditions.

The fresh air damper should be positioned fully closed whenever the fabric cover is rolled down and secured since outside air cannot be drawn in through the fresh air inlet screen.

Under normal operating conditions, before starting the air conditioner in any mode, make sure that the fabric cover on the back of the cabinet is rolled up and secured, that the condenser fan intake screen and fan guard are in place and unobstructed, and that the evaporator fan intake and discharge grille louvers are fully open. **EXCEPTIONS:** Under extreme climatic conditions, such as blowing snow, which might enter the compressor section, the unit may be operated in the VENT, LOW HEAT or HIGH HEAT mode with the fabric cover rolled down and snapped in place. When operated in this manner, outside air cannot be drawn through the fresh air damper, which should be positioned fully closed. The fabric cover cannot be rolled down if the unit is connected to a NBC filter.

Do not operate in the cool mode with the fabric cover rolled down.

OPERATION IN EXTREME HEAT

These air conditioners are designed to operate in temperatures up to 120 F (49 C). Extra care should be taken to minimize the cooling mode when operating in extremely high temperatures.

Some of the steps that may be taken include checking all openings in the enclosure, especially doors and windows, to ensure they are tightly closed; use shades or awnings to shut out direct rays of the sun; limit the use of electrical lights and other heat-producing equipment; Limit the amount of hot air coming in through the fresh air damper that is essential for ventilation; clean the filter, mist eliminator, and coils more frequently; and increase the frequency of PMCS.

FILTERS

To maintain the highest capacity of the unit, the evaporator intake filter and fresh air screen should be cleaned weekly or more often if necessary. Dirty filters reduce the flow of air across the evaporator coil, thereby reducing the capacity of the air conditioner.

GUARDS AND LOUVERS

Keep all guards and louvers clean and free of any obstructions to maintain full airflow through the air conditioner. Ensure the condenser louver in the rear of the unit is open.

COILS

Clean evaporator and condenser coils as frequently as necessary to prevent dirt or other matter from obstructing the airflow.

CAUTION

Do not disturb electrical wiring that has been exposed to extremely low temperatures. Both the wires and the installation brittle and are easily broken.

During cool weather, DO NOT start in COOL mode for at least four hours.

OPERATION IN EXTREME COLD

The air conditioner is designed to work in HEAT mode when outside temperatures are down to -50 F (-45 C), and in the COOL mode when outside temperatures are down to 0 F (-18 C). Extra care should be taken to minimize the heating mode when operating in extremely low temperatures. Some steps that may be taken include checking all of the openings in the enclosed, especially doors and windows, to ensure they are secure; Open shades and awnings on the south-facing side of the enclosure to permit entry of direct rays of the sun; Limit the amount of cold air entering in through the fresh air damper that is essential for ventilation.

NOTE

It is recommended to weather strip the installation of storm doors and windows, if appropriate, when running at extremely LOW temperatures and for extended periods of time.

Before attempting to start the unit in COOL mode, or when fresh air is being used during the HEAT mode, roll up the canvas cover and ensure all exposed air openings are clear of ice and snow.

When the unit is to be used at low temperatures in the COOL mode, jump the low refrigerant pressure cutout switch (WP 0050 00). To obtain maintenance assistance, notify supervisor.

OPERATION IN DUSTY OR SANDY CONDITIONS

Dusty and sandy conditions can seriously reduce the efficiency of the air conditioner by clogging the air filter, mist eliminator, and coils. This will restrict the volume of airflow. Accumulation of dust or sand in the condenser coil and/or in the compressor compartment may cause overheating of the refrigeration system. Dust or sand may clog the condensation trap and water drain lines.

Clean filters, mist eliminators, coils, and all other areas of dust and sand accumulation. In extreme conditions, clean filters daily. Limit the amount of dust and sand entering through the fresh air damper essential for ventilation. Roll down and secure the fabric cover on the back of the cabinet during periods of shutdown and increase the frequency of PMCS.

NOTE

Never operate the unit without having the air filters in place.

OPERATION UNDER WET OR HUMID CONDITIONS

WARNING

Make sure power is disconnected from air conditioner before touching any wiring or other electrical parts.

The Keco model F9000H-4SPFI air conditioner is designed for normal exposure to the elements, so it is reasonably waterproof. Take special precautions to keep equipment dry. If installed outdoors, cover equipment with a waterproof cover when not in use. Remove cover during dry periods. Take all necessary precautions to keep electrical components free from moisture. Keep vent damper actuator closed during heavy rain.

OPERATION IN SALT AIR OR SEA SPRAY AREAS

WARNING

Disconnect power source prior to washing the air conditioner.

Salt air or sea spray may cause similar clogging problems as encountered when operating in a dusty or sandy environment. The nature of salt presents serious corrosion problems. When operating in a salt air or sea spray environment, frequently clean all exposed surfaces with fresh water to remove salt deposits. Roll down and secure the fabric cover on the back of the cabinet whenever the air conditioner is not in operation.

Wash the exterior and the condenser section frequently. Be careful not to damage the electrical system with water.

Paint all exposed areas where paint has cracked, peeled, or blistered, or report condition to unit maintenance. Cover all exposed areas of polished metal with a light coat of grease.

OPERATION DURING EMERGENCY CONDITIONS

When operation is anticipated under potential nuclear-biological-chemical (NBC) conditions, a NBC filtering unit should be fabricated and connected to the fresh air intake.

During periods when full electrical power is in critically short supply and the air conditioner cannot be turned off completely, it should be operated in VENTILATE mode when possible.

END OF WORK PACKAGE

CHAPTER 3.
OPERATOR TROUBLESHOOTING PROCEDURES

**OPERATOR'S MAINTENANCE
AIR CONDITIONER, HORIZONTAL, COMPACT
(NSN 4120-01-502-1319)**

TROUBLESHOOTING INDEX AND OPERATIONAL CHECKOUT AND TROUBLESHOOTING PROCEDURES

TROUBLESHOOTING INDEX

Table 1. Symptom Index.

TROUBLE	MALFUNCTION NO.
Air Conditioner	
Does Not Start in Any Mode-----	1
Reduced Cooling Capacity-----	2
Reduced Heating Capacity-----	3
Too Much Heat-----	4

USE OF TROUBLESHOOTING TABLE

Troubleshooting Procedures (Table 1) contains troubleshooting information useful to operators in diagnosing and correcting malfunctions or unsatisfactory operation of the air conditioner. The table lists the common malfunctions an operator is most likely to encounter. Corrective actions indicate what steps the operator should take.

The operator should determine the malfunction symptom that most closely describes the immediate situation and then perform the corrective action steps in the order listed.

This manual does not list all possible malfunction symptoms that may be encountered, nor can it list all possible corrective actions.

A malfunction or corrective action beyond the scope of the operator's capabilities must be reported to unit maintenance.

Table 1. Troubleshooting Procedures

MALFUNCTION 1

UNIT DOES NOT START

SYMPTOM

Air conditioner does not start in any mode.

MALFUNCTION

No power supplied to unit.

CAUTION

During cool weather, DO NOT start in COOL mode for at least four hours.

CORRECTIVE ACTION

Check input power.

Check to see if CONTROL CIRCUIT BREAKER or COMPR CIRCUIT BKR has tripped.

CORRECTIVE ACTION

Reset the circuit breakers.

NOTE

If power is still not supplied to the unit, notify unit maintenance.

MALFUNCTION 2

REDUCED COOLING CAPACITY

SYMPTOM

Air conditioner is not cooling properly.

MALFUNCTION

Air conditioner is not cooling properly.

CORRECTIVE ACTION

1. Check that the MODE SELECTOR switch is turned to COOL. If not, turn the switch to cool at this time.
2. Check the operation of the TEMPERATURE SELECTOR. Set the maximum control a COOLER; then, if the condition improves, adjust properly.
3. Check that the supply and air return louvers are properly adjusted. Re-adjust louvers when necessary.
4. Check that excessive hot, outside air is not entering through the fresh air damper. If so, fully close the damper and adjust properly when the condition improves.
5. Check that all doors, windows, and other openings in the room or enclosed area are tightly closed. Close all openings when necessary.
6. Check the speed of the EVAPORATOR FAN. Set the switch to HIGH speed.
7. Check the condenser air inlet guard and discharge air louver for obstruction. Remove obstruction as necessary.
8. Check the condition of the refrigerant in the sight glass. If the refrigerant color is greenish-yellow in color or numerous bubble appear in the window, turn the selector to OFF and contact direct support maintenance.

MALFUNCTION 3

REDUCED HEATING CAPACITY

SYMPTOM

Air conditioner is not heating properly.

MALFUNCTION

The mode selector switch is not properly set.

CORRECTIVE ACTION

Set the switch on LOW or HIGH heat.

The temperature selector switch is not properly operating.

CORRECTIVE ACTION

Set the control to WARMER. If condition improves, adjust properly.

The supply and return louvers are not properly adjusted.

CORRECTIVE ACTION

When necessary, adjust the air louvers to the open position.

Cold, outside air is entering through the fresh air damper.

CORRECTIVE ACTION

Make sure the damper is fully closed. If the condition improves, adjust accordingly.

Check that all doors, windows, and other openings in the room or enclosed space are tightly closed.

MALFUNCTION 4

TOO MUCH HEAT

SYMPTOM

The air conditioner is dispensing too much heat.

MALFUNCTION

The mode selector switch is not properly set.

CORRECTIVE ACTION

Set the switch on LOW HEAT. (When the MODE SELECTOR switch is set for HIGH HEAT, half of the heaters will operate ALL of the time).

The TEMPERATURE SELECTOR switch is not operating properly.

CORRECTIVE ACTION

Adjust to a slightly COOLER setting if necessary.

OPERATIONAL CHECKOUT PROCEDURES

Operate the unit per procedures found in WP 0005 00. If the unit fails to operate according to the procedures listed, refer to troubleshooting section to select an appropriate corrective action. If the malfunction does not fall within the capabilities of the operator, contact Unit Maintenance.

END OF WORK PACKAGE

CHAPTER 4.
UNIT TROUBLESHOOTING PROCEDURES

UNIT MAINTENANCE
AIR CONDITIONER, HORIZONTAL, COMPACT
(NSN 4120-01-502-1319)

TROUBLESHOOTING INDEX AND OPERATIONAL CHECKOUT AND TROUBLESHOOTING PROCEDURES

USE OF TROUBLESHOOTING TABLE

Troubleshooting Procedures (Table 1) contains troubleshooting information useful to operators in diagnosing and correcting malfunctions or unsatisfactory operation of the air conditioner. The table lists the common malfunctions an operator is most likely to encounter. Corrective actions indicate what steps the operator should take.

The operator should determine the malfunction symptom that most closely describes the immediate situation and then perform the corrective action steps in the order listed.

This manual does not list all possible malfunction symptoms that may be encountered, nor can it list all possible corrective actions.

A malfunction or corrective action beyond the scope of the operator’s capabilities must be reported to unit maintenance.

Table 1. Troubleshooting Procedures

The Symptom Index contains troubleshooting information useful to unit maintenance technicians in diagnosing and correcting malfunctions or unsatisfactory operation of the air conditioner.

The Troubleshooting Table lists the common malfunction symptoms and unsatisfactory performance characteristics that technicians are most likely to encounter. Included are the test and inspection steps to determine the cause and the corrective action(s) that should be performed for each possible cause lifted.

The technicians should first find the malfunction symptom or unsatisfactory performance characteristic in the table that most closely describes the immediate situation. Then perform the test and inspections, and determine corrective action steps in the order in which they are listed.

This manual cannot list all possible situations that may be encountered, nor can it list all test and inspection and corrective action steps that may be taken. If a condition is encountered that cannot be resolved within the capabilities and experience of unit maintenance personnel, then assistance should be requested from direct support maintenance.

SYMPTOM INDEX

TROUBLE	MALFUNCTION NO.
Air Conditioner	
Unit Does not Start-----	1
Insufficient Cooling-----	4
Unit Operates Continuously on Cooling Cycle -----	8
Unit Fails to Heat -----	11
Excessive Noise -----	12
Evaporator	
Evaporator Fan Does not Start-----	2
Evaporator Fan Stops During Operation -----	2
Evaporator Air Output Volume Low-----	9

Troubleshooting Index - continued

TROUBLE	MALFUNCTION NO.
Condenser	
Condenser Fan Fails to Operate-----	3
Condenser Air Outlet Volume Low-----	10
Compressor	
Compressor Will Not Start-----	5
Compressor Short Cycles-----	6
Compressor Starts Then Stops During Operation-----	7

TROUBLESHOOTING TABLE

MALFUNCTION 1

UNIT DOES NOT START

SYMPTOM

Air Conditioner does not start in any mode

MALFUNCTION

No input power connection.

CORRECTIVE ACTION

If power has been disconnected, re-connect the power.

CAUTION

If the input power has been disconnected for an unknown period of time, DO NOT start the unit in COOL MODE until the power has been reconnected for at least four hours.

Circuit breakers are tripped.

CORRECTIVE ACTION

Reset the circuit breakers.

Loose or damaged electrical connectors and damaged wires in wiring harness.

CORRECTIVE ACTION

Tighten or replace connectors or repair damaged wires as necessary.

No internal wiring for correct connection.

CORRECTIVE ACTION

Be sure internal wiring is connected to terminal board TB3.

There are defective circuit breakers.

CORRECTIVE ACTION

Replace as necessary. (WP 0030 00, WP 0039 00, Compressor Circuit Breakers).

There is a defective MODE SELECTOR switch.

CORRECTIVE ACTION

Replace if defective. (WP 0029 00).

MALFUNCTION 2

EVAPORATOR FAN DOES NOT START OR STOP DURING OPERATION.

SYMPTOM

Conditioned evaporator air fan does not start or stop during operations in any mode.

MALFUNCTION

The evaporator fan motor is not operating.

CORRECTIVE ACTION

Test the motor and replace if defective. (WP 0044 00).

The MODE SELECTOR switch is not operating properly.

CORRECTIVE ACTION

Test the switch and replace if defective. (WP 0029 00).

The electrical connections and wiring are damaged or missing.

CORRECTIVE ACTION

Tighten or replace connectors and repair or replace any damaged wires.
(WP 0025 00).

The fan shows signs of binding.

CORRECTIVE ACTION

Relieve the binding or replace the fan as necessary. (WP 0044 00).

MALFUNCTION 3

CONDENSER FAN FAILS TO OPERATE

SYMPTOM

The condenser fan will not operate.

MALFUNCTION

The condenser fan and motor fails to operate.

CORRECTIVE ACTION

Test the motor and replace if necessary. (WP 0047 00).

Electrical connections and wiring are loose or damaged.

CORRECTIVE ACTION

Tighten or replace connectors and repair or replace any damaged wires.

The fans show signs of binding.

CORRECTIVE ACTION

Relieve the binding or replace the fan as necessary. (WP 0047 00).

The condenser fan relay is not operating properly.

CORRECTIVE ACTION

Replace relay if necessary. (WP 0038 00).

The phase sequence relay is not operating properly.

CORRECTIVE ACTION

Replace relay if necessary. (WP 0036 00).

MALFUNCTION 4

INSUFFICIENT COOLING

SYMPTOM

The unit will not cool properly.

MALFUNCTION

The mode selector switch is improperly set.

CORRECTIVE ACTION

Make sure the MODE SELECTOR switch is properly set in the COOL position.

The sight glass liquid level indicator shows a yellow, milky, or bubble refrigerant.

CORRECTIVE ACTION

If the sight-glass liquid-level indicator shows that the refrigerant is greenish-yellow, milky, or bubbly, low-level or excessive moisture is occurring. Notify your supervisor.

The evaporator and condenser coils are dusty or dirty.

CORRECTIVE ACTION

Clean coils with 25-30 psi compressed air. (WP 0048 00) and (WP 0051 00).

The evaporator's return air filter is dirty.

CORRECTIVE ACTION

Clean the filter when necessary. (WP 0018 00).

The mist eliminator is dirty.

CORRECTIVE ACTION

Remove and clean or replace the mist eliminator. (WP 0021 00).

The airflow is obstructed.

CORRECTIVE ACTION

Remove any obstructions on both the evaporator and condenser sides.

The supply outlet louver is blocked or in a closed position.

CORRECTIVE ACTION

Remove any blockage and/or open the louver.

The evaporator fan motor is worn or defective.

CORRECTIVE ACTION

If necessary, replace the motor.

The evaporator and condenser fans have loose or defective parts.

CORRECTIVE ACTION

Tighten the setscrew or replace the fan.

The ambient temperature exceeds 120 Degrees F (49 C).

CORRECTIVE ACTION

Notify your supervisor.

MALFUNCTION 5

COMPRESSOR WILL NOT START

SYMPTOM

The compressor will not start.

MALFUNCTION

The compressor, control circuit breaker, and selector switches are not properly set.

CORRECTIVE ACTION

Reset the controls.

The contacts of the HIGH-or-LOW cut out switches are open.

CORRECTIVE ACTION

Reset the pressure switches. Notify your supervisor if condition continues.

There are loose electrical connections or faulty wiring.

CORRECTIVE ACTION

Tighten any loose connections and fix any faulty wiring. (WP 0030 00) and (WP 0013 00).

The control circuit breakers or selector switches are not properly set.

CORRECTIVE ACTION

Conduct continuity checks on the control circuit breakers or selector switches to ensure they are properly set. If necessary, fix any open circuits and replace wires.

The phase sequence relay is not operating properly.

CORRECTIVE ACTION

If necessary, replace bad relay.

There is no continuity across primary and secondary winding of the control transformer for defective windings.

CORRECTIVE ACTION

If necessary, replace transformer. (WP 0042 00).

The forward and reverse resistances of the rectifier assembly diodes are not operating properly.

CORRECTIVE ACTION

If necessary, replace the bad rectifier. (WP 0041 00).

The operation of the time delay relay is not timed correctly.

CORRECTIVE ACTION

Observe the operation of the time delay relay. If necessary, replace the bad relay. (WP 0035 00).

The compressor relay is not operating properly.

CORRECTIVE ACTION

Substitute the compressor relay, known to be good, check the operation and replace the bad relay if necessary.

There is no continuity in the pins.

CORRECTIVE ACTION

Test the compressor motor by checking the continuity of the following pins, at the compressor electrical receptacle. (WP 0013 00) and (WP 0085 00).

- a) Continuity should exist in pins A and B, B and C, and C and A.
- b) Continuity should NOT exist in pins A, B, and C, and the compressor housing.
- c) In pins D and E, continuity should exist when the compressor is cool enough for the internal thermostat to be closed. If the compressor is hot, let it cool down and then retest.

MALFUNCTION 6

COMPRESSOR SHORT CYCLES

SYMPTOM

The compressor short cycles.

MALFUNCTION

There are obstructions in front of the condenser screen.

CORRECTIVE ACTION

Remove any obstructions and/or roll up and secure the canvas cover.

There is dirt inside the condenser coil.

CORRECTIVE ACTION

Clean the condenser coil if necessary. (WP 0051 00).

The HIGH PRESSURE cutout switch and RESET is tripped.

CORRECTIVE ACTION

RESET the switch, then push and release the HIGH PRESSURE switch.

The LOW PRESSURE cutout switch is tripped.

CORRECTIVE ACTION

RESET the LOW PRESSURE switch, then push and release the LOW PRESSURE switch.

MALFUNCTION 7

COMPRESSOR STARTS THEN STOPS DURING OPERATION

SYMPTOM

Compressor Starts, then goes out on overload.

MALFUNCTION

The condenser fan motor experiences a failure.

CORRECTIVE ACTION

Observe the condenser fan and motor for failure and replace the motor if necessary. (WP 0047 00).

The condenser coil or guard is dirty.

CORRECTIVE ACTION

Clean the coil and/or the guard.

The air outlet louvers are stuck or jammed in a closed position.

CORRECTIVE ACTION

If necessary, free the louvers and the control cable, adjust the control, or notify your supervisor if actuating cylinder is not working properly.

MALFUNCTION 8

UNIT OPERATES CONTINUOUSLY ON COOLING CYCLE

SYMPTOM

The unit operates continuously on cooling cycle.

MALFUNCTION

The TEMPERATURE SELECTOR switch is in the wrong position.

CORRECTIVE ACTION

Check the position of the TEMPERATURE SELECTOR switch. If necessary, move the selector to WARMER. (WP 0027 00).

The TEMPERATURE SELECTOR is broken or defective.

CORRECTIVE ACTION

Check the TEMPERATURE SELECTOR switch and replace if defective. (WP 0027 00).

MALFUNCTION 9

EVAPORATOR AIR OUTPUT VOLUME LOW

SYMPTOM

The output volume of evaporator air is low.

MALFUNCTION

Louvers or filters are dirty.

CORRECTIVE ACTION

Clean louvers or filters and replace if necessary.

The evaporator coil is dirty or icy.

CORRECTIVE ACTION

De-Ice and clean coil when necessary. (WP 0048 00).

The evaporator fan is damaged.

CORRECTIVE ACTION

Inspect the evaporator fan for damage and replace the fan, if necessary. (WP 0044 00).

The evaporator fan has a bad motor.

CORRECTIVE ACTION

Check for a bad fan motor and replace motor if necessary. (WP 0044 00).

The EVAPORATOR FAN SPEED switch set at a low speed.

CORRECTIVE ACTION

Check to ensure the EVAPORATOR FAN SPEED switch is NOT set at LOW speed. If necessary, reset the switch to HIGH speed.

MALFUNCTION 10

CONDENSER AIR OUTLET VOLUME LOW

SYMPTOM

The condenser air outlet is running low.

MALFUNCTION

The condenser coil or guard is dirty.

CORRECTIVE ACTION

Check for a dirty condenser coil or guard and clean the coil and guard if necessary. (WP 0051 00).

The condenser fan is damaged.

CORRECTIVE ACTION

Inspect the condenser fan for damage and replace fan if necessary. (WP 0047 00).

The air outlet louvers are stuck or jammed in the closed position.

CORRECTIVE ACTION

Check to be sure the air outlet louvers are not stuck or jammed in the closed position. If necessary, free louvers and control cable, adjust the control, and notify your supervisor if the actuating cylinder not working properly.

MALFUNCTION 11

UNIT FAILS TO HEAT

SYMPTOM

The air conditioner will not heat.

MALFUNCTION

The MODE SELECTOR switch is not properly set.

CORRECTIVE ACTION

If necessary, set the MODE SELECTOR switch to the LOW HEAT or the HIGH HEAT setting and wait for temperature change. (WP 0029 00).

The TEMPERATURE SELECTOR switch is not properly set.

CORRECTIVE ACTION

Ensure the TEMPERATURE SELECTOR switch is set properly. Reset the switch if necessary.

The evaporator return air filter is dirty.

CORRECTIVE ACTION

Clean the filter if necessary.

The evaporator fan motor is not operating properly.

CORRECTIVE ACTION

Replace the motor if necessary. (WP 0044 00).

There is no existing continuity of the TEMPERATURE SELECTOR switch and the MODE SELECTOR switch.

CORRECTIVE ACTION

Replace bad switch if necessary.

There are loose connections or damage to the heaters and the wiring.

CORRECTIVE ACTION

Inspect for loose connections or damage the heaters and wiring. If necessary, tighten all loose connections, fix bad wiring, and replace bad heater elements.

There is no existing continuity in the heater relay coils.

CORRECTIVE ACTION

Check for continuity in the heater relay coils and replace the bad relay when necessary.

The heater high-temperature cutout thermostatic switch is not operational.

CORRECTIVE ACTION

Check the operation of the heater high-temperature cutout thermostatic switch. It should open when the temperature rises above setting. Replace bad thermostatic switches when necessary.

MALFUNCTION 12**EXCESSIVE NOISE****SYMPTOM**

The air conditioner is making excessive noise.

MALFUNCTION

The evaporator fan or the condenser fan is vibrating.

CORRECTIVE ACTION

If necessary, tighten fans on the shafts and tighten all mounting screws.

The evaporator fan and the condenser fan show signs of wear.

CORRECTIVE ACTION

Check the evaporator and condenser fan for wear, as indicated from noisy operation or excessive side-to-side movement. If necessary, replace the worn or bad motor. (WP 0044 00 and WP 0047 00).

The compressor makes a consistent “knock” or “chatter” noise.

CORRECTIVE ACTION

If this condition occurs, stop the air conditioner and notify your supervisor.

END OF WORK PACKAGE

CHAPTER 5.

DIRECT SUPPORT TROUBLESHOOTING PROCEDURES

**DIRECT SUPPORT MAINTENANCE
AIR CONDITIONER, HORIZONTAL, COMPACT
(NSN 4120-01-502-1319)**

TROUBLESHOOTING INDEX AND OPERATIONAL CHECKOUT AND TROUBLESHOOTING PROCEDURES

GENERAL

For use of the authorized common tools and equipment, refer to the Modified Table of Organization and Equipment (MTOE) applicable to your unit.

Test, Measurement, and Diagnostic Equipment (TMDE) and all support equipment include electrical test equipment, standard pressure and vacuum gauges, vacuum pumps, and charging manifolds and are found as standard equipment in any direct support refrigeration shop.

Repair parts are listed and illustrated in TM9-4120-428-24P. No special tools are required for direct support maintenance of the air conditioner.

USE OF TROUBLESHOOTING TABLE

The Troubleshooting Table lists the most common malfunctions found during operation or maintenance of the air conditioner. Tests, inspections, and corrective actions should be performed in the order listed.

For a specific malfunction, refer to the Symptom Index before performing the procedures listed in the Troubleshooting Table.

This manual cannot list all malfunctions that may occur. Tests, inspections, and corrective actions are listed for the most common malfunctions only. If a malfunction is not listed, notify your supervisor.

TROUBLESHOOTING INDEX

Symptom Index

TROUBLE	MALFUNCTION NO.
 AIR CONDITIONER	
Insufficient Cooling	3
Noisy During Operation	7
Operates Continuously on Cool	5
 COMPRESSOR	
Will Not Start	1
Short Cycle	2
 REFRIGERANT SYSTEM	
Contamination	6
Continuously Losing Refrigerant	4

NOTE

Before proceeding with the troubleshooting procedures, check Troubleshooting Procedures for Unit Maintenance.

MALFUNCTION 1

COMPRESSOR WILL NOT START.

SYMPTOM

The compressor will not start.

MALFUNCTION

The LOW and HIGH-pressure switches are tripped.

CORRECTIVE ACTION

Check that both the LOW and HIGH PRESSURE switches are not tripped. To reset, press and release the LOW and HIGH PRESSURE switches. If the switch does NOT stay in, check and/or replace the switches. (WP 0079 00) and (WP 0078 00).

The compressor motor thermal cutoff switch is not operational.

CORRECTIVE ACTION

Conduct an operational check on the compressor motor thermal cutoff switch. If the thermal cutoff switch is defective, replace the compressor. (WP 0088 00).

The compressor shows signs of burnout.

CORRECTIVE ACTION

Replace the compressor if it shows signs of burn out. (WP 0088 00).

MALFUNCTION 2

COMPRESSOR SHORT CYCLES

SYMPTOM

The compressor short cycles.

MALFUNCTION

The head pressure is either too high or too low.

CORRECTIVE ACTION

1. Check the head pressure (high pressure side).
 - a) If the pressure is too high, check the HIGH PRESSURE cutout switch and replace if defective. (WP 0078 00).
 - b) If the pressure is excessive and the sight glass is clear, release any excess refrigerant. Release the pressure until the requirements of (WP 0076 00) are met.
2. Check the head pressure (low pressure side) and add refrigerant if low.

The quench valve is defective.

CORRECTIVE ACTION

Check the quench valve and replace if defective.

The internal overload switch on the compressor motor is defective.

CORRECTIVE ACTION

If the internal overload switch is defective, replace the compressor motor.

Solenoid valves L1 and L2 are defective.

CORRECTIVE ACTION

Check and repair solenoid valves L1 and L2 or replace defective valves if necessary.

MALFUNCTION 3

INSUFFICIENT COOLING

SYMPTOM

The air conditioner is not putting out enough cool air.

NOTE

Frost on the evaporator coil is usually caused by either an obstruction to airflow or dirty coils, filters, or mist eliminators.

MALFUNCTION

The condenser air discharge louvers are closed.

CORRECTIVE ACTION

Check the actuating cylinder to ensure that the condenser discharge louvers are open and replace if defective. (WP 0077 00).

The sight glass window displays a bubbly, green refrigerant charge.

CORRECTIVE ACTION

Operate air conditioner for at least 15 minutes with the TEMPERATURE SELECTOR switch in the maximum COOLER position. Check the sight glass window; the center should be bubble-free and green. Add refrigerant if the charge is low.

NOTE

A clogged dehydrator may cause bubbles in the refrigerant. (WP 0070 00).

Refrigerant is leaking from the air conditioner.

CORRECTIVE ACTION

Repair or change defective parts as necessary.

Solenoid Valves L1 and L2 are defective.

CORRECTIVE ACTION

Check solenoid valves L1 and L2 and repair or replace if defective. (WP 0074 00) and (WP 0075 00).

The pressure regulator valve is defective.

CORRECTIVE ACTION

Check the pressure regulator valve and replace if defective. (WP 0076 00).

The primary expansion valve is not operating properly.

CORRECTIVE ACTION

Check the primary expansion valve for proper operation and replace if defective.
(WP 0075 00).

The quench valve is not operating properly.

CORRECTIVE ACTION

Check the quench valve for proper operation and replace if defective. (WP 0073 00).

MALFUNCTION 4

REFRIGERANT SYSTEM CONTINUOUSLY LOSING REFRIGERANT

SYMPTOM

The air conditioner is continuously losing refrigerant.

MALFUNCTION

The refrigerant tubing and its components show signs of leaking.

CORRECTIVE ACTION

WARNING

Unit contains R-22, a chemical substance that harms public health and the environment by destroying ozone in the upper atmosphere.

CAUTION

Qualified personnel should service the equipment.

1. Check the refrigerant tubing and its components for leaks using a leak detector; repair or replace defective parts as necessary. (WP 0086 00).
2. Check the pressure relief valve and replace if defective. (WP 0081 00).

MALFUNCTION 5

UNIT OPERATES CONTINUOUSLY ON COOL

SYMPTOM

The unit continuously operates on cool.

MALFUNCTION

Solenoid valve L1 is defective.

CORRECTIVE ACTION

Check solenoid valve L1 and replace if defective. (WP 0074 00).

MALFUNCTION 6

CONTAMINATED REFRIGERANT

SYMPTOM

The refrigerant is contaminated.

MALFUNCTION

The refrigerant is contaminated.

CORRECTIVE ACTION

The refrigerant is contaminated if the sight glass appears yellow after the compressor has run for about an hour, instead of green. Replace the dehydrator if necessary. (WP 0070 00).

MALFUNCTION 7

AIR CONDITIONER NOISY DURING OPERATION.

SYMPTOM

The air conditioner remains noisy during operation.

MALFUNCTION

The primary expansion valve is defective.

CORRECTIVE ACTION

Check the primary expansion valve and replace if defective. (WP 0072 00).

The quench valve is defective.

CORRECTIVE ACTION

Check the quench valve and replace if defective. (WP 0073 00).

The compressor is making noise internally and is loosely mounted.

CORRECTIVE ACTION

If necessary, tighten the loose mounting and replace the compressor if defective.

END OF WORK PACKAGE

CHAPTER 6.
OPERATOR MAINTENANCE INSTRUCTIONS

OPERATOR'S MAINTENANCE
AIR CONDITIONER, HORIZONTAL, COMPACT
(NSN 4120-01-502-1319)
PREVENTATIVE MAINTENANCE CHECKS AND SERVICES (PMCS)

GENERAL

Preventative Maintenance Checks and Services (PMCS) are essential to the overall efficient operation of the air conditioner and to prevent possible damage that might occur through neglect or failure to observe warning symptoms in a timely manner. Checks and Services performed by operators are limited to those functions that can be accomplished from the outside of the cabinet. The PMCS table lists the inspections for and care of the air conditioner required to keep it in good operating condition.

PREVENTATIVE MAINTENANCE CHECKS AND SERVICES**Before Operation**

Always observe the WARNINGS and CAUTIONS contained in this technical manual. Always read the plates installed on the equipment that are associated with the functions you are about to perform. Perform the before (B) PMCS checks from Table 1.

During Operation

Always observe the WARNINGS and CAUTIONS contained in this technical manual and the plates that are installed on the equipment that are associated with certain operational functions. Perform the during (D) PMCS checks from Table 1.

After Operation

Perform the after (A) PMCS checks from Table 1.

When Equipment Fails To Operate

Troubleshoot within your capabilities and with proper equipment. Report any deficiencies using DA PAM 738-750.

Service Interval Column

The Interval column of PMCS table (Table 1) explains when to complete a service or a check.

Procedure Column

The procedure column of the PMCS table (Table 1) explains how a required service or check should be performed.

Reporting and Correcting Deficiencies

If the air conditioner does not perform as it should, refer to Chapter 3, Operator Troubleshooting Procedures. Report any malfunctions or failures on DA Form 2404 or refer to DA Form 738-750.

When Equipment is Not Ready/Not Available

This column of the PMCS table (Table 1) explains when the air conditioner cannot be used.

NOTE

Within designated intervals, these checks are to be performed in the order listed. If the equipment must be kept in continuous operation, service and check only those items that can be serviced and checked without disturbing operation. Make complete services and checks at a time when equipment can be shut down.

Operator Preventative Maintenance Checks and Services.

OPERATOR PREVENTATIVE MAINTENANCE CHECKS AND SERVICES							
ITEM NO.	INTERVAL				ITEM TO BE CHECKED OR SERVICED	PROCEDURE	EQUIPMENT NOT READY/AVAILABLE IF:
	B-BEFORE		A-AFTER				
	D-DURING		M-MONTHLY				
B	D	A	M				

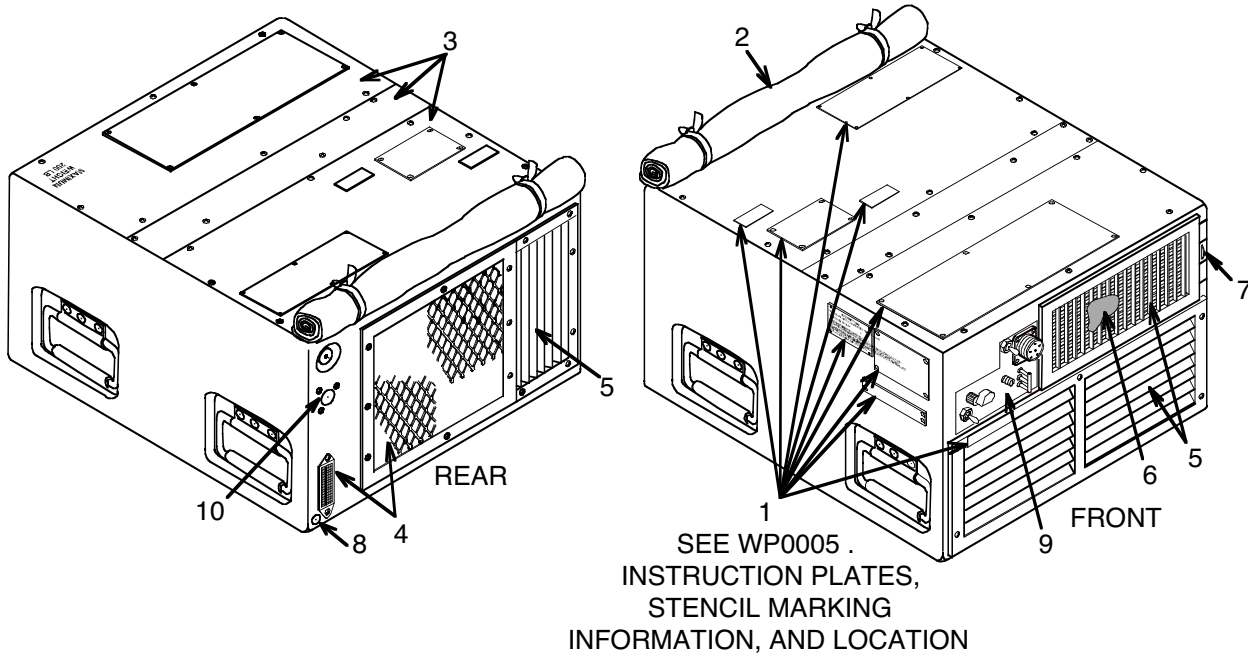

1	*				Information Plates	Check for legibility and loose or missing hardware.	
2	*			*	Fabric Cover	Check that the cover is rolled up for normal operation. Roll cover down and check for condition of snaps, mildew, tears, and worn edges.	
3	*				Panels	Check for cracks, dents, or missing hardware.	
4	*				Screens and Guards	Check for obstructions, damage, and loose or missing hardware.	
5	*				Louvers	Check for obstructions, damage, proper adjustment, and loose or missing hardware. Check Louvers for freedom of operations. Lubricate as required.	

OPERATOR PREVENTATIVE MAINTENANCE CHECKS AND SERVICES							
ITEM NO.	INTERVAL				ITEM TO BE CHECKED OR SERVICED	PROCEDURE	EQUIPMENT NOT READY/AVAILABLE IF:
	B-BEFORE D-DURING		A-AFTER M-MONTHLY				
	B	D	A	M			
6	*			*	Air Filter	Check for cleanliness of filter.	
7	*			*	Fresh Air Damper	Check for freedom of operation and proper adjustment.	The control wheel is either missing or inoperable.
8		*			Condensate Drain	Check that NO water is dripping anywhere, except around the drain.	Water is leaking in an area that would cause damage or be a hazard.
9	*				Control Module	Inspect for damage, secure mounting, and proper operation in accordance with paragraph 2-6.	Control module is damaged or operating improperly.
10		*			Refrigerant Sight Glass	After 15 minutes of operation in the maximum cooling mode, check for bubbles or a milky flow indicating low refrigerant charge. Check for yellow color, which indicates presence of moisture.	Bubbles, milky flow, or yellow color is observed.

END OF WORK PACKAGE

OPERATOR'S MAINTENANCE
AIR CONDITIONER, HORIZONTAL, COMPACT
(NSN 4120-01-502-1319)
MAINTENANCE ITEMS (VARIOUS)

GENERAL:

There are no operator maintenance procedures.

END OF WORK PACKAGE

UNIT MAINTENANCE
AIR CONDITIONER, HORIZONTAL, COMPACT
(NSN 4120-01-502-1319)
LUBRICATION INSTRUCTIONS

GENERAL

The refrigerant compressor and its drive motor are hermetically sealed in a canister. The compressor is supplied with a complete charge of oil and requires no lubrication. The evaporator and condenser fan motors have permanently lubricated, sealed bearings. No lubrication of these items is required.

MECHANICAL LUBRICATION

The only mechanical items that require lubrication are the conditioned air supply and return louvers, the condenser air discharge louver and control linkages, and the devices that operate the fresh air damper door. These points should be checked and lubricated as necessary, during preventative maintenance service. A few drops of light oil should be applied to pivot points, bearing surfaces, and linkages to prevent or eliminate stiffness or binding. Wipe off all excess oil with a cloth or paper towel. These items are in an area of high volume airflow and excess oil will tend to attract and accumulate dust particles from the passing air. Graphite may be used as an alternate lubricant during extreme cold weather conditions.

END OF WORK PACKAGE

CHAPTER 7.
UNIT MAINTENANCE INSTRUCTIONS

UNIT MAINTENANCE
AIR CONDITIONER, HORIZONTAL, COMPACT
(NSN 4120-01-502-1319)
SERVICE UPON RECEIPT

SITE AND SHELTER REQUIREMENTS

The air conditioner is designed so that it is adaptable to a variety of installation arrangements. Most typical installations are made by preparing an opening in an exterior wall of the room, or enclosure to be conditioned, and positioning the air conditioner so that the front of the cabinet is inside the room, or enclosure, and the back of the cabinet is outside of the conditioned area. Minimum requirements for all installation includes:

- A level surface capable of bearing the weight of the air conditioner of which to set the base. To ensure proper condensate drainage, level from side to side and front to back. An unobstructed flow of air from outside the conditioned area to the intake and discharge of the condenser fan (back face of air conditioner). Refer to the illustrations in this work package for mounting dimensions.
- An unobstructed flow of air from inside the conditioned area to the intake and discharge openings (front face of air conditioner).
- An unobstructed flow of air from the outside conditioned area to the fresh air intake. (Back face of air conditioner.)
- Access to the front and back of the air conditioner for routine operation, servicing, and necessary maintenance actions.
- Sufficient access to allow for the removal of the front and rear top panels is necessary.
- A source of 208 volt, 3 phase, 400 hertz input power rated at 10 amps for the F9000H-4SPFI. The power source outlet should be located as near as possible to the installed location of the air conditioner. The power source wiring must include a disconnect switch. Provisions should be made to insure that power is not disconnected during normal operation and that the disconnect switch is not used to turn off the air conditioner for normal shutdown.
- Make sure no sources of dangerous fumes are near the fresh air intake.
- If possible, avoid a location where the condenser and fresh air intake will be laden with dust, soot dirt, smoke, or other debris.

SERVICE UPON RECEIPT OF MATERIAL

UNLOADING

The air conditioner is packaged in a container designed for shipment and handling with the cabinet in the upright position. The base of the container is constructed as a shipping pallet.

To unload the air conditioner:

1. Remove all blocking and tie downs that may have been used to secure the container to the carrier.

CAUTION

Use care in handling to avoid damage to the air conditioner. If an overhead lifting device is used, use an appropriate sling so the weight of the unit is borne by the base of the shipping container.

2. Use a forklift, or other suitable material handling equipment, to remove the packaged unit from the carrier.

To unpack the Air Conditioner:

1. Prior to unpacking, move the air conditioner into the area where it will be installed.

NOTE

The shipping container may be retained for reuse for mobility purposes, if frequent relocation of the air conditioner is expected.

2. To remove the shipping container, cut the metal bands that hold the top and sides of the container to the base. Lift the container vertically and remove it from the base and cabinet.
3. Remove cushioning around the top of the cabinet and retain, if reuse is expected. Remove the presentation barrier by tearing around the bottom of the cabinet. Remove the technical publications envelope and the accessory sack and put them in a secure place.

NOTE

Leave the cabinet bolted to the shipping cabinet until it is time to place it in the installation position. All receiving inspections can be conducted without removal from the pallet.

Receiving inspection

Perform receiving inspection of the air conditioner as follows:

1. Inspect the equipment for damage incurred during shipping. If the equipment has been damaged, report damage on DD Form 6, Packaging Improvement Report.
2. Check for shipment completeness by comparing the equipment to the packing slip. Report all discrepancies in accordance with DA Pamphlet 738-750, The Army Maintenance Management System.
3. Check for equipment modification.

WARNING

The unit weight (less the shipping pallet) is 190 pounds (86.2 kg) for the F9000H-4SPFI. Use a forklift when moving or lifting the unit on the shipping pallet. Use four people, one at each handle, to lift the unit into position.

4. To remove the pallet, raise the unit using a forklift. Remove four bolts from the bottom of the pallet.

INSTALLATION INSTRUCTIONS**Preparation for installation**

Two input power connectors are provided on the air conditioner. Connector J1 is located on the front of the air conditioner, above the control panel module. Connector J11 is located on the rear of the air conditioner, in the upper left corner.

NOTE

Air conditioners are shipped from the factory wired for the use of the J1 power connector. If this connector is used, no change is necessary.

Determine which connector best suits your installation. If power source is inside the conditioned area, use J1. If power source is outside the conditioned area, use J11. If the J11 connector is to be used on the F9000H-4SPFI, leads TB1-1--TB3-1--TB1-2, TB3-2, and TB1-3—TB3-3 on the terminal board, TB3 must be moved from terminals 1, 2, and 3 to terminals 4, 5, and 6 respectively. Proceed as follows:

1. Remove the top front panel (evaporator section) from the air conditioner (See WP 0016 00).
2. Disconnect wire TB1-1—TB3-1 from TB3 terminal 1 and reconnect to terminal 4.

Installation Instructions - continued

3. Disconnect wire TB1-2 –TB3-2 from TB3 terminal 2 and reconnect to terminal 5.
4. Disconnect wire TB1-3 –TB3-3 from TB3 terminal 3 and reconnect to terminal 6.
5. If operating in COOL mode in low ambient conditions, it may be necessary to jump out the Low Pressure Cutout Switch (LPCO). (See WP 0050 00).
6. Attach the top front panel (evaporator section) to the air conditioner.

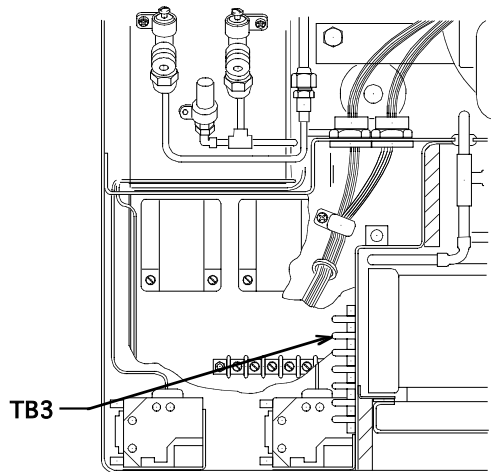
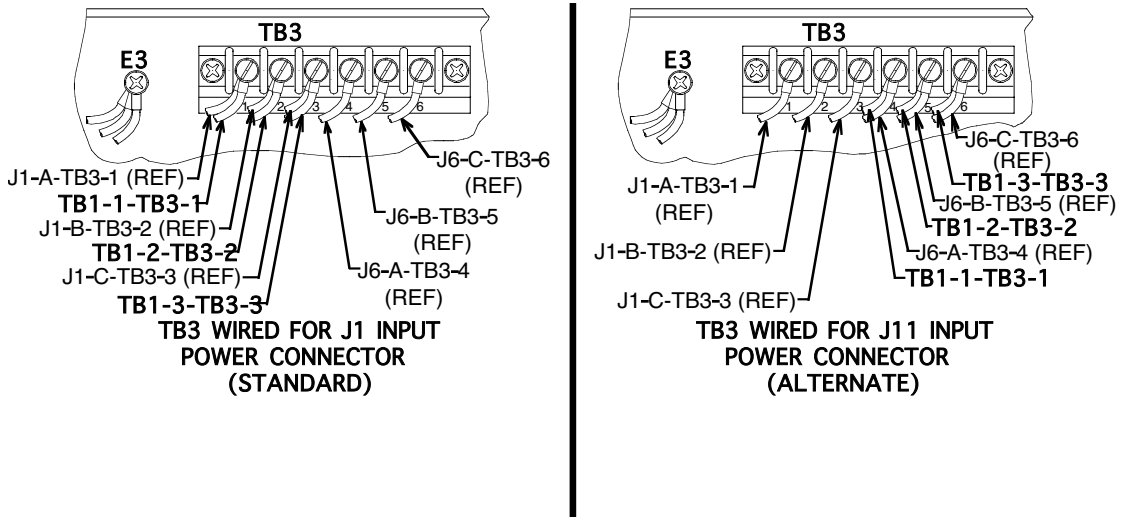

UPPER LEFT CORNER WITH TOP COVERS REMOVED

POWER CONNECTOR CONFIGURATION

Installation Instructions - continued

Connectors are provided to permit remote installation of the control module. To install the control module in a remote location, within the conditioned space, the following steps must be taken.

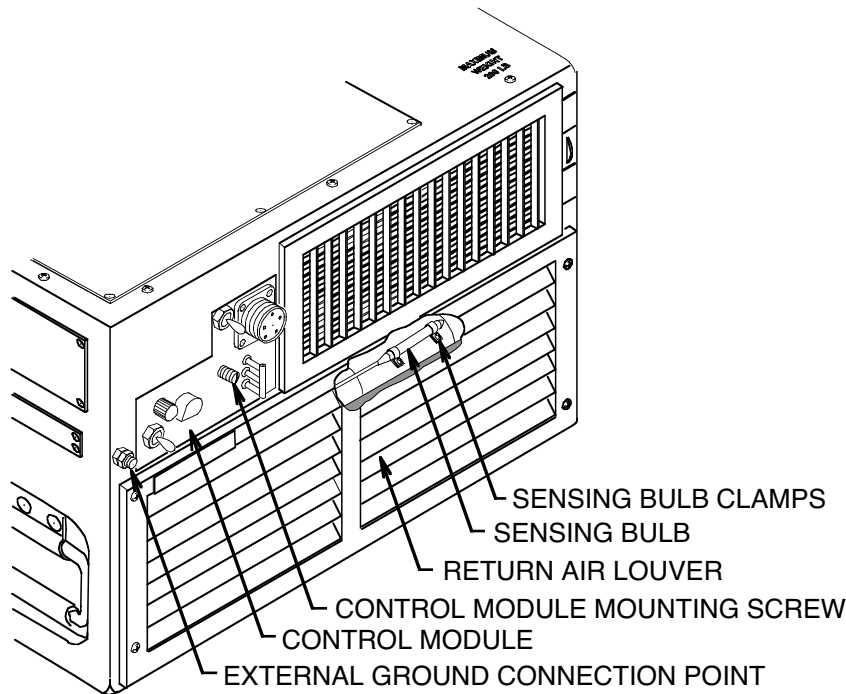

1. Remove the return air louver (WP 0018 00).
2. Loosen the sensing bulb clamp screws and slip the sensing bulb out of clamp.
3. Loosen the control module mounting screw and carefully pull control module out of unit. Use care to avoid damage to sensing line.
4. Carefully work the sensing bulb through the frame and out of the unit.

NOTE

The sensing bulb controls thermostatic action of the TEMPERATURE SELECTOR. It should be mounted where a true room or enclosure temperature will be indicated. Do not place near heat of cool producing items. False temperature control will result.

5. Determine where the control module will be located.
6. Secure the control module and the sensing bulb.
7. The receptacle and plug needed to fabricate the interconnecting cables are provided with the unit. Determine the length of wire needed to connect the plug and the receptacle between the unit and control module.
8. Fabricate the interconnecting cable for the F9000H-4SPFI and connect cable between P2A/B and J2A/B per the Remote Control Cable Diagram.
9. Install the air louver.
10. To reinstall the control module, See WP 0026 00.

No other preparation is necessary if the air conditioner is installed by the typical exterior wall opening method and operated as a self-contained unit.

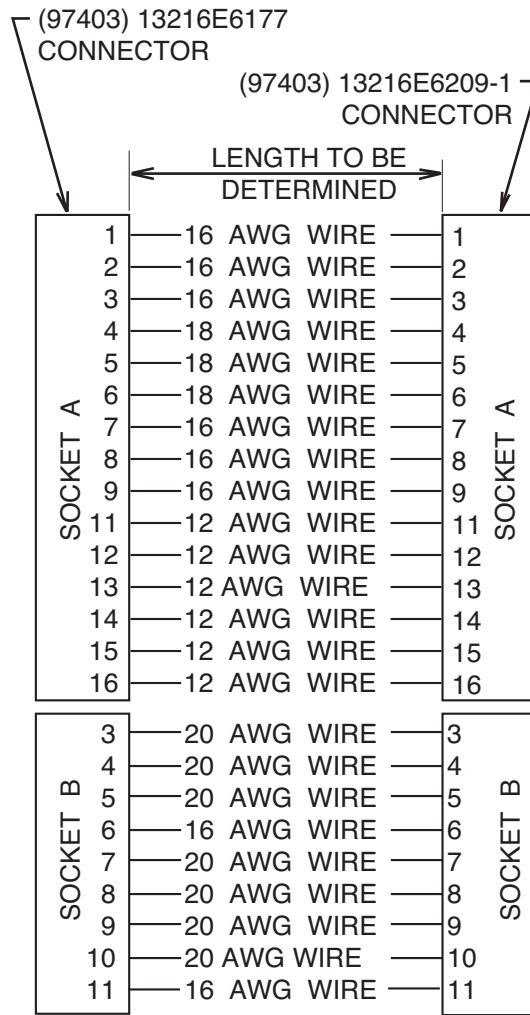

INTERCONNECTING REMOTE CONTROL CABLE DIAGRAMS

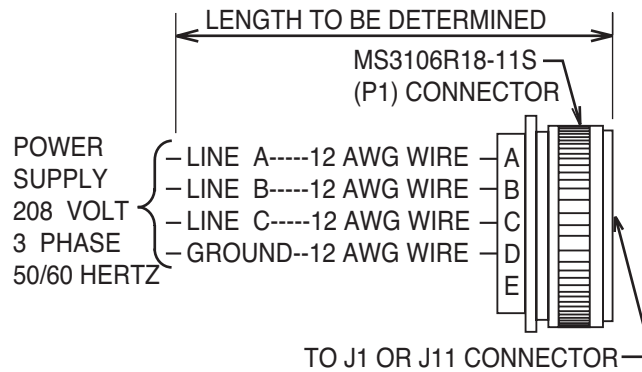

INPUT POWER CABLE DIAGRAM

INSTALLATION

Appropriate alterations to the facility to accommodate the selected method of installation must be completed before actual installation of the air conditioner.

Shelter/Enclosure Preparation

The following information provides a typical through-the-wall type installation. Slightly altering these instructions may be necessary in order to accommodate a specific application. WP 0055 00 provides a through-the-wall installation that allows for the removal of the front and rear panels for service.

1. Determine best location for air conditioner and make a cutout in the wall, slightly larger than the dimension of the air conditioner.
2. Fabricate a mounting platform or brace. Drill mounting holes to match the holes in the bottom of the air conditioner. See illustrations in this work package for dimensions.
3. Use adequate equipment or at least four people to lift the air conditioner into position.
4. Secure the unit to the platform (or brace) with the mounting hardware provided with the unit. See WP 0013 00 for the cross section view of the bottom mounting holes and hardware.

WARNING

Severe injury or death may result if personnel fail to observe safety precautions. For safe operation, connect a 10 AWG (minimum) ground wire to the air conditioner to ensure the shelter is properly grounded.

1. Connect a 10 AWG (minimum) ground wire from the shelter ground to the air conditioner external ground. The air conditioner external ground port is located on the front left side of the control module.
2. Fill in and seal the area around the air conditioner to prevent the loss of conditioned air. Flexible plastic foam and pressure sensitive tape may be used.
3. Fabricate an input cable of required length using the MS3106R18-11S connector, supplied with the air conditioner, for connection to J1 or J11. (See chart below and Figure 4-4, Sheet 7). If J11 connector is used, be sure the wiring to TB3 terminal board is relocated.

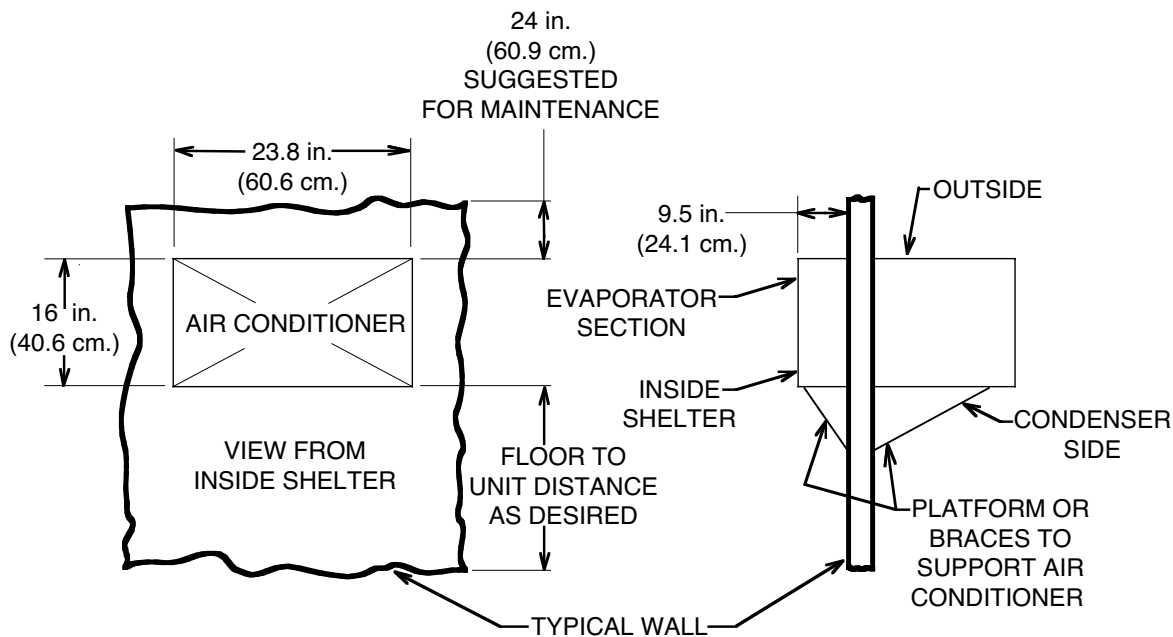

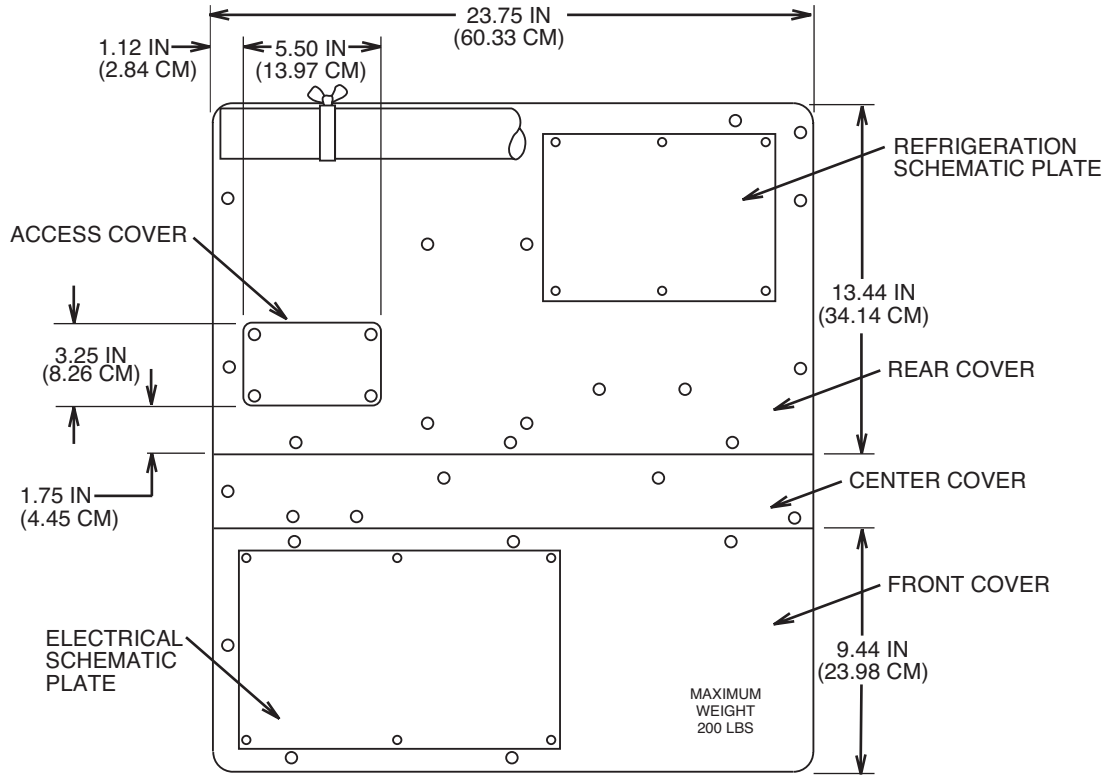

TOP VIEW

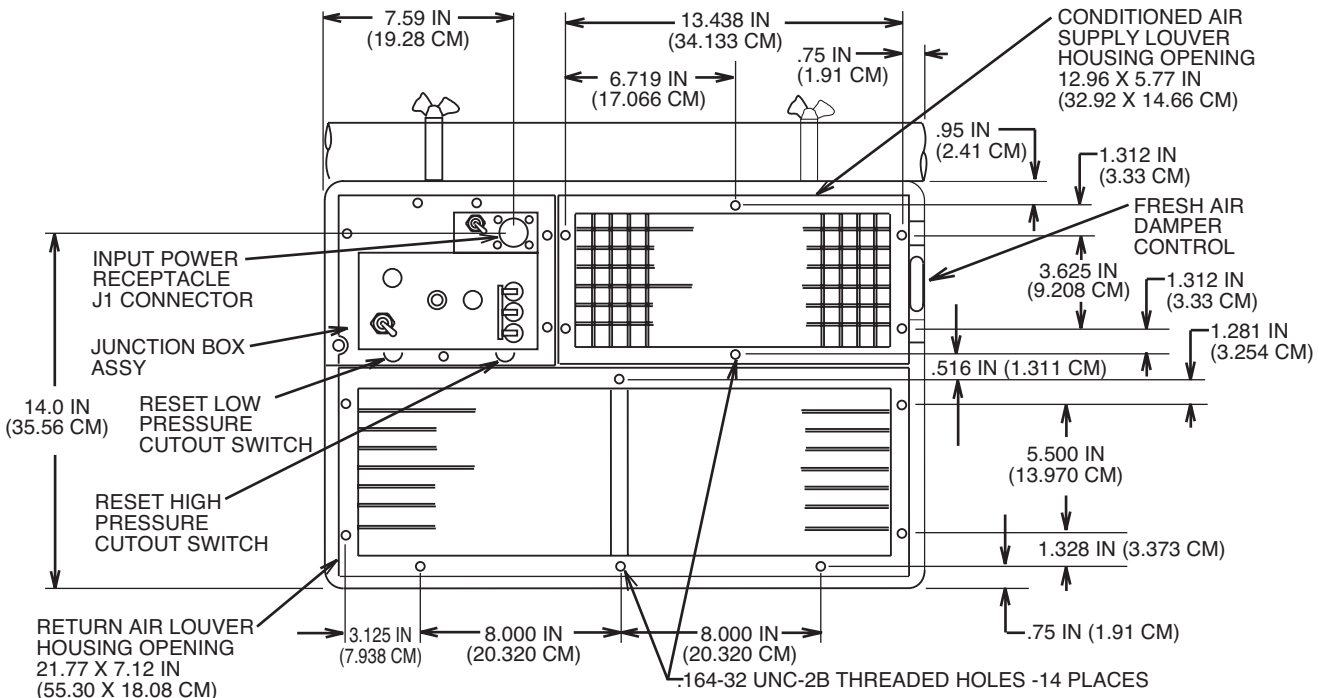

FRONT VIEW

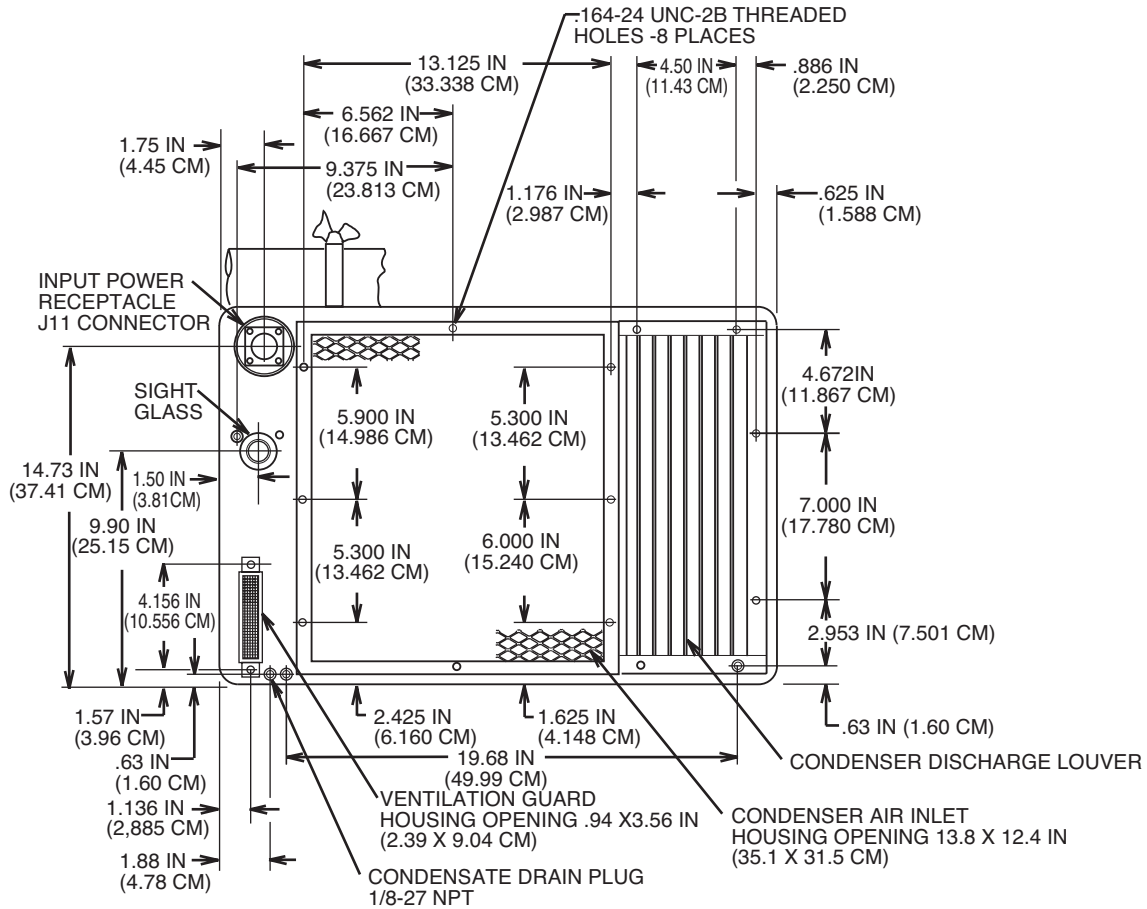

REAR VIEW

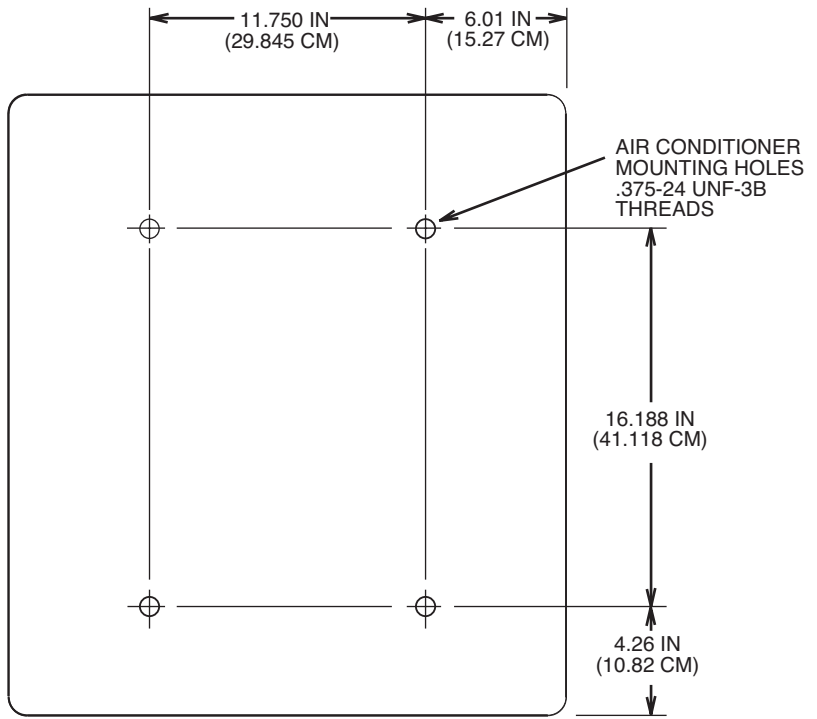

BOTTOM VIEW

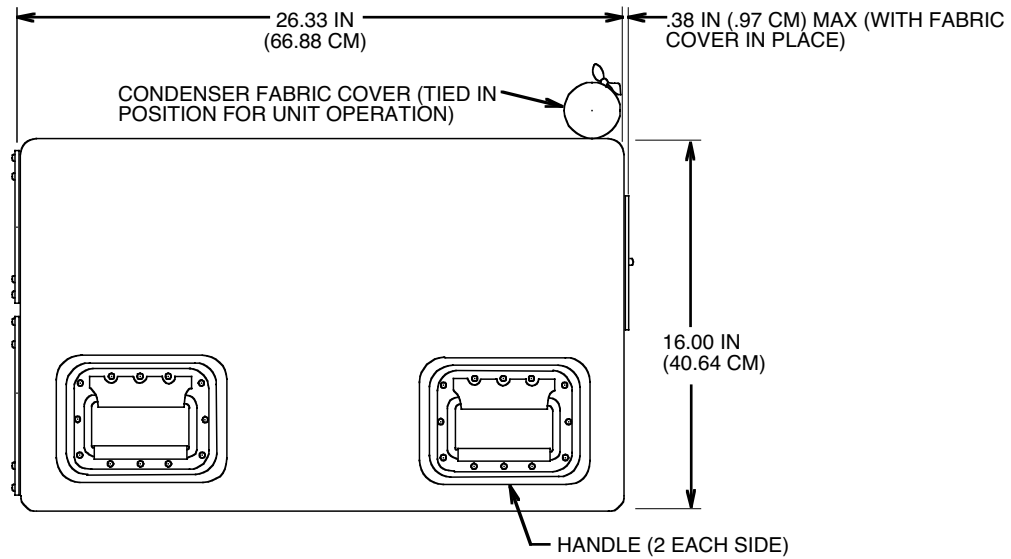

RIGHT SIDE VIEW

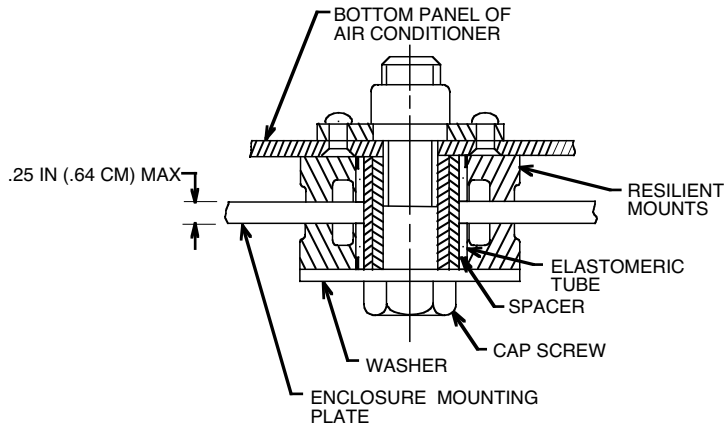

CROSS SECTION OF BOTTOM MOUNTING HOLE AND HARDWARE (TYPICAL 4 PLACES)

1. Remove the condensate drain plug from the lower left rear corner of the air conditioner. Connect a drain line if the air conditioner is mounted in a location where water pouring from the drain is objectionable or creates a hazard. The fitting must have a male 1/8 -27 NPT connection to the unit. Hose, rigid pipe, or tubing can be used to directly drain water to a more desirable location.
2. Connect the power cable to input power source. (F9000H-4SPFI, 208 volt, 3 phase, 400 hertz air conditioner)
3. Run operational checks in accordance with WP 0005 00.

NOTE

For more information on air conditioner installations, refer to MIL-HDBK-116, Environmental Control of Small Shelters.

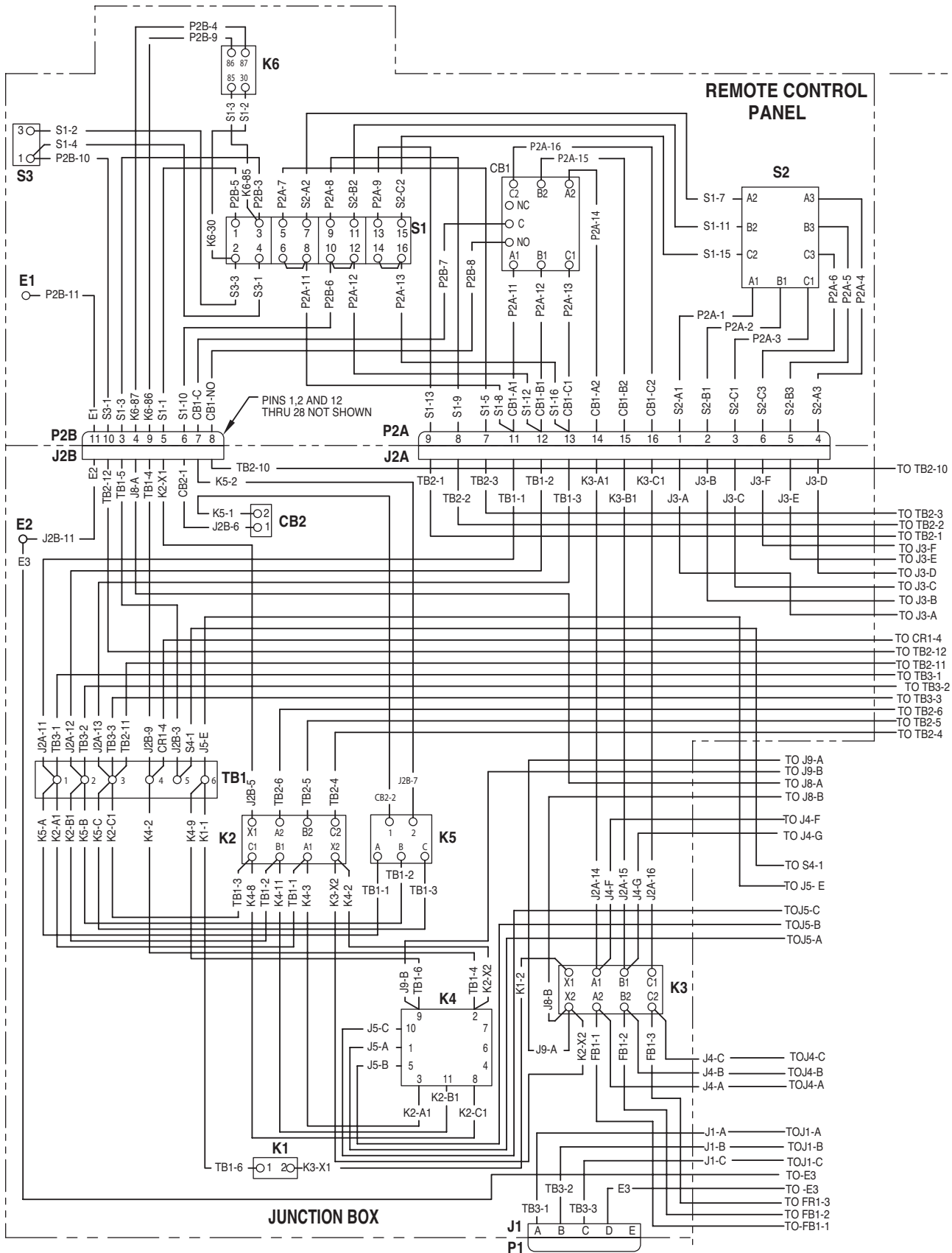

Wiring Diagram (Sheet 1 of 2)

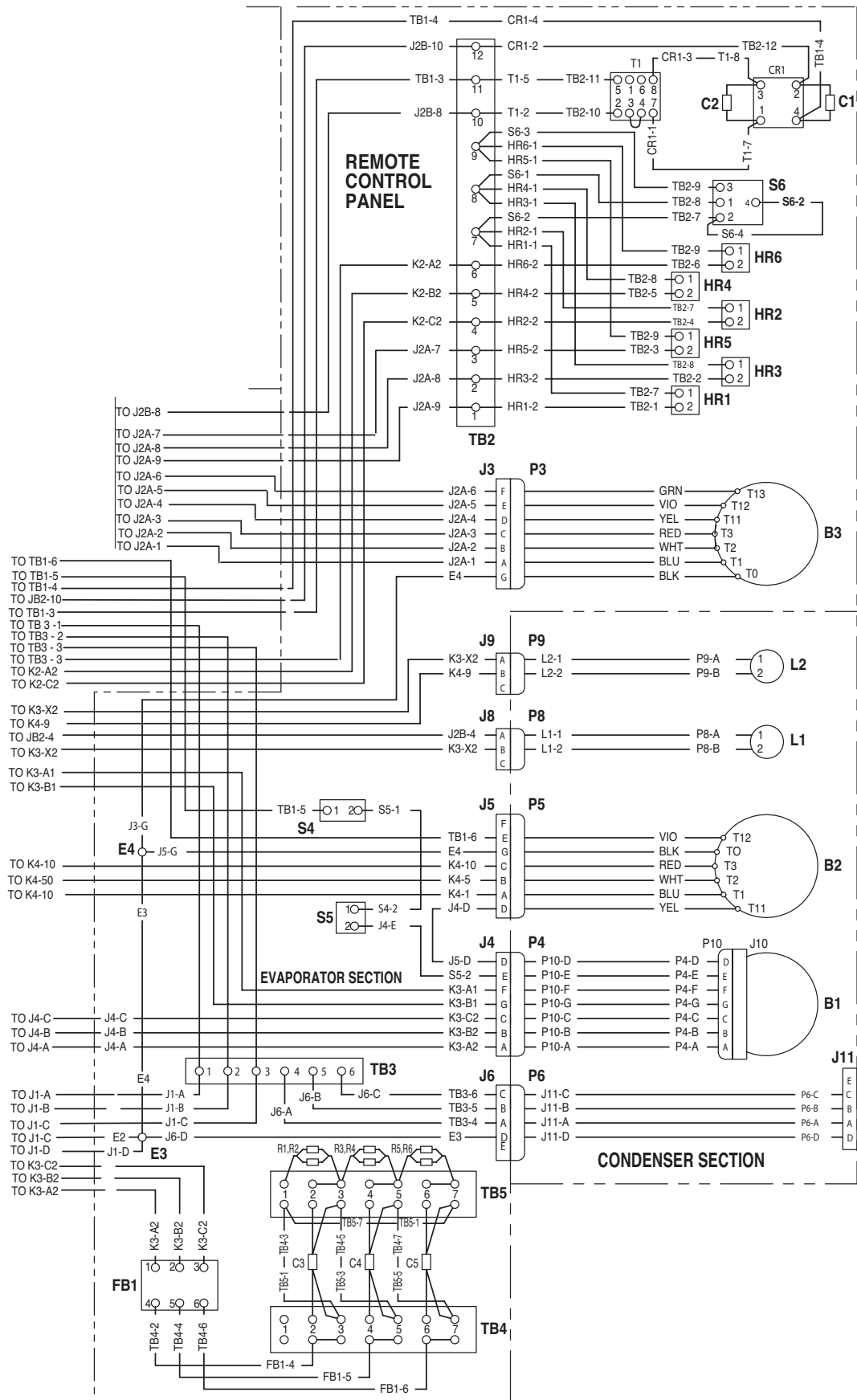

Wiring Diagram (Sheet 2 of 2)

COMPONENT REFERENCE LIST	
ELEC REF DES	DESCRIPTION
B1	COMPRESSOR, RECIPROCATING
B2	MOTOR, CONDENSER FAN
B3	MOTOR, EVAPORATOR FAN
C1	CAPACITOR, FILTER
C2	CAPACITOR
C3 THRU C5	CAPACITOR
CB1	CIRCUIT BREAKER
CB2	CIRCUIT BREAKER, CONTROL
CR1	RECTIFIER, SEMICONDUCTOR DEVICE
F1 THRU F3	FUSE
FB1	FUSE BLOCK
E1	TERMINAL STUD, (CONTROL MODULE GND)
E2	TERMINAL STUD (JUNCTION BOX GND)
E3 AND E4	TERMINAL STUD (SYSTEM GND)
HR1 THRU 6	HEATER ELEMENT
J1 AND J11	CONNECTOR, RECEPTACLE, POWER INPUT
J2	CONNECTOR, RECEPTACLE, JUNCTION BOX
J3	CONNECTOR, RECEPTACLE, EVAPORATOR FAN
J4	CONNECTOR, RECEPTACLE, COMPRESSOR
J5	CONNECTOR, RECEPTACLE, CONDENSER FAN
J6	CONNECTOR, RECEPTACLE, POWER INPUT
J8	CONNECTOR, RECEPTACLE, SOLENOID VALVE BY-PASS
J9	CONNECTOR, RECEPTACLE, SOLENOID VALVE EQUALIZER
J10	CONNECTOR, RECEPTACLE, COMPRESSOR
K1	RELAY, TIME DELAY
K2	RELAY, HEATER
K3	RELAY, COMPRESSOR MOTOR
K4	RELAY, CONDENSER FAN
K5	RELAY, PHASE SEQUENCE
K6	RELAY, ROTARY SWITCH
L1	VALVE, SOLENOID, BY-PASS
L2	VALVE, SOLENOID, PRESSURE EQUALIZER
P1	CONNECTOR, PLUG, POWER INPUT
P2	CONNECTOR, PLUG, CONTROL MODULE
P3	CONNECTOR, PLUG, EVAPORATOR FAN
P4	CONNECTOR, PLUG, COMPRESSOR
P5	CONNECTOR, PLUG, CONDENSER FAN
P6	CONNECTOR, PLUG, POWER INPUT
P8	CONNECTOR, PLUG, SOLENOID VALVE BY-PASS
P9	CONNECTOR, PLUG, SOLENOID VALVE EQUALIZER
P10	CONNECTOR, PLUG, COMPRESSOR
R1 THRU R6	RESISTOR
S1	SWITCH, ROTARY SELECTOR
S2	SWITCH, TOGGLE
S3	SWITCH, TEMPERATURE CONTROL
S4	SWITCH, HIGH PRESSURE CUTOUT
S5	SWITCH, LOW PRESSURE CUTOUT
S6	SWITCH, HEATER CUTOUT
T1	TRANSFORMER
TB1	TERMINAL BOARD, JUNCTION BOX
TB2	TERMINAL BOARD
TB3	TERMINAL BOARD, POWER INPUT
TB4	TERMINAL BOARD
TB5	TERMINAL BOARD

TO ENERGIZE THE UNIT FROM THE AUXILIARY POWER INPUT SOURCE (J11). THE LEAD ORIGINATING FROM TB1-1, TB1-2 AND TB1-3 ON TB3-1, -2 AND -3 MUST BE CHANGED TO TB3-4, -5, AND -6 RESPECTIVELY.

Wiring Diagram Legend

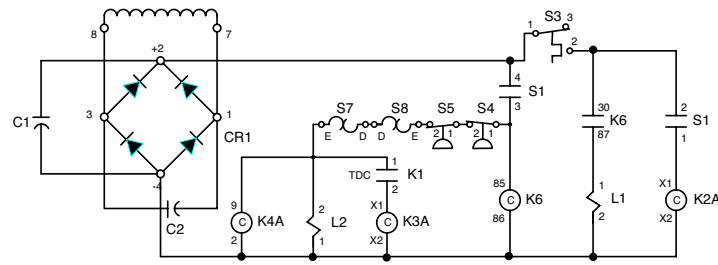
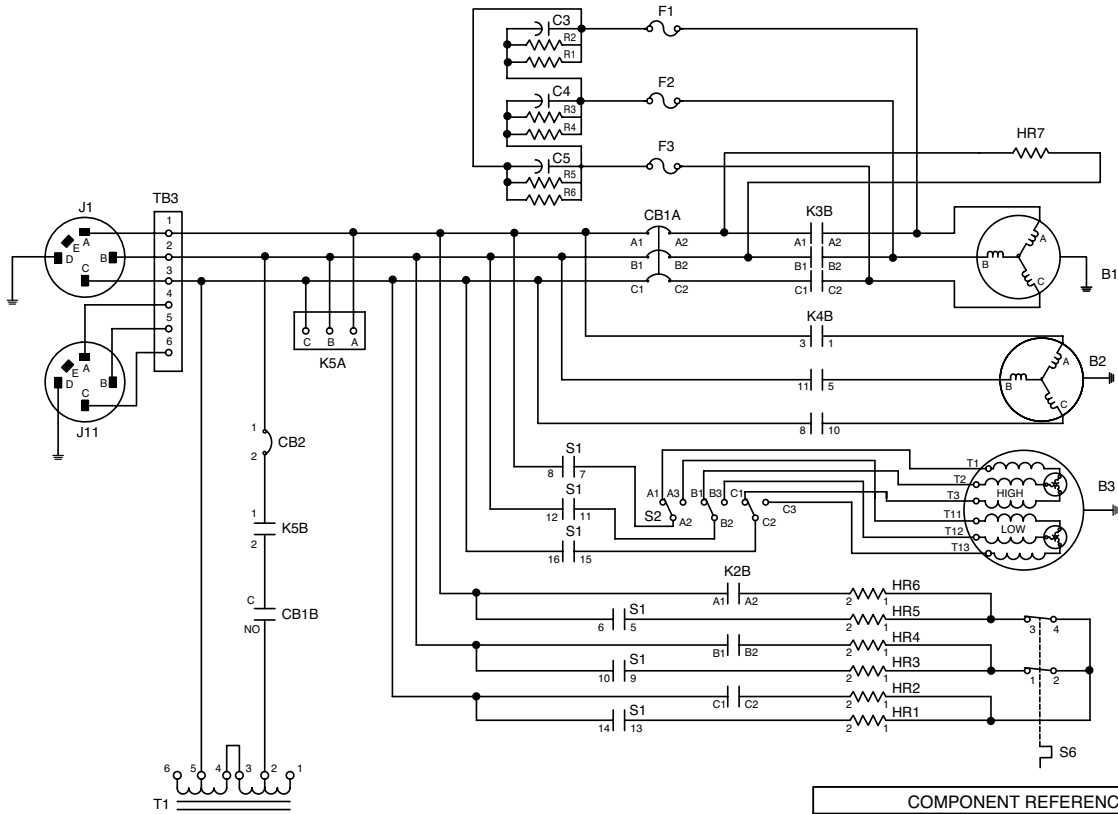

COMPONENT REFERENCE LIST	
ELEC REF DES	DESCRIPTION
B1	COMPRESSOR, RECIPROCATING
B2	MOTOR, CONDENSER FAN
B3	MOTOR, EVAPORATOR FAN
C1	CAPACITOR, FILTER
C2	CAPACITOR
C3 THRU C5	CAPACITOR
CB1	CIRCUIT BREAKER, COMPRESSOR
CB2	CIRCUIT BREAKER, CONTROL
CR1	RECTIFIER, SEMICONDUCTOR DEVICE
F1 THRU F3	FUSE
HR1-6	HEATER ELEMENT
HR7	CRANKCASE HEATER
J1, J11	CONNECTOR, RECEPTACLE, POWER INPUT
K1	RELAY, TIME DELAY
K2	RELAY, HEATER
K3	RELAY, COMPRESSOR MOTOR
K4	RELAY, CONDENSER FAN
K5	RELAY, PHASE SEQUENCE
K6	RELAY, ROTARY SWITCH
L1	VALVE, SOLENOID, BY-PASS
L2	VALVE, SOLENOID, PRESSURE EQUALIZER
R1 THRU R6	RESISTOR
S1	SWITCH, ROTARY SELECTOR
S2	SWITCH, TOGGLE
S3	SWITCH, TEMPERATURE CONTROL
S4	SWITCH, HIGH PRESSURE CUTOUT
S5	SWITCH, LOW PRESSURE CUTOUT
S6	SWITCH, HEATER CUTOUT
S7	THERMAL SWITCH
S8	THERMAL SWITCH
T1	TRANSFORMER
TB3	TERMINAL BOARD, POWER INPUT

SWITCH POSITION	FUNCTION	SWITCH DECK AND TERMINALS CONNECTED			
		1	2	3	4
1	COOL	3 AND 4	7 AND 8	11 AND 12	15 AND 16
2	VENT	-----	7 AND 8	11 AND 12	15 AND 16
3	OFF	-----	-----	-----	-----
4	(LOW) HEAT	1 AND 2	7 AND 8	11 AND 12	15 AND 16
5	(HIGH) HEAT	1 AND 2	5 AND 6 7 AND 8	9 AND 10 11 AND 12	13 AND 14 15 AND 16

TO ENERGIZE THE UNIT FROM THE AUXILIARY POWER INPUT SOURCE (J11). THE LEADS ORIGINATING FROM TB3-1, -2 AND -3 MUST BE CHANGED TO TB3-4, -5 AND -6 RESPECTIVELY.

Electrical Schematic

END OF WORK PACKAGE

UNIT MAINTENANCE
AIR CONDITIONER, HORIZONTAL, COMPACT
(NSN 4120-01-502-1319)
PREVENTIVE MAINTENANCE CHECKS AND SERVICES

GENERAL

Systematic, periodic, Preventative Maintenance Checks and Services (PMCS) are essential to insure that the air conditioner is ready for operation in any mode at all times. The purpose of a preventative maintenance program is to discover and correct defects before they can cause serious damage or complete failure of the equipment. An effective preventative maintenance program must begin with training all operators to report to unit maintenance all unusual conditions noted during daily checks or actual operation. All defects discovered during maintenance inspections must be recorded together with the corrective action taken on DD Form 2404, Equipment Inspection and Maintenance Worksheet.

INSPECTION AND SERVICE

A schedule for the unit preventative maintenance inspection and service should be established immediately after installation of the air conditioner. A quarterly interval, equal to three calendar months or 250 hours of operation, whichever comes first, is recommended for usual operating conditions. When operating under unusual conditions, such as a dusty or sandy environment, it may be necessary to reduce the interval to monthly and even less if conditions are extreme.

Table 2 lists the unit preventative maintenance checks and services that should be performed at quarterly, or otherwise established intervals. The PMCS items in the table have been arranged and numbered in a logical sequence to provide for greater personnel efficiency and minimal amount of required maintenance downtime. The item number column will be used as a source of item numbers for the TM Number Column on DA Form 2404.

WARNING

Dangerous, possibly fatal electric shock is imminent. Be sure to disconnect input power before taking apart the air conditioner for PMCS.

GENERAL LUBRICATION

The refrigerant compressor and its drive motor are hermetically sealed in a canister. The compressor is supplied with a complete charge of oil and requires no lubrication. The evaporator and condenser fan motors have permanently sealed and lubricated bearings. No lubrication of these items is required.

MECHANICAL LUBRICATION

The only mechanical items that may need lubrication are the conditioned air supply and return louvers, the condenser air discharge louver and control linkages, and the devices that operate the fresh air damper door. These points should be checked and lubricated, as necessary, during preventative maintenance service. A few drops of oil should be applied to the pivot points, bearing surfaces, and linkages in order to prevent or eliminate stiffness or binding. Wipe off excess oil with a cloth or a paper towel. These items are in a high-volume airflow, therefore, excess oil can attract and accumulate dust particles from the passing air. Graphite may be used as an alternate lubricant during extreme cold weather operation.

Unit Preventative Maintenance Checks and Services.

ITEM NO.	ITEMS TO BE INSPECTED/SERVICED	PROCEDURES
----------	--------------------------------	------------

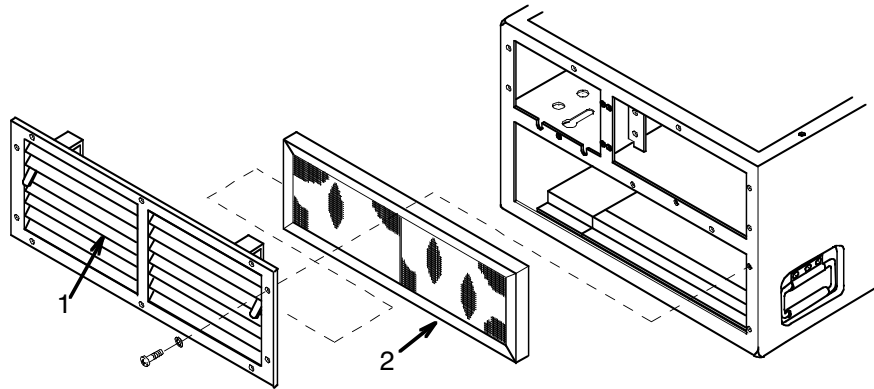

- | | | |
|---|------------------------|--|
| 1 | Return Air Louver | <ol style="list-style-type: none"> 1. Check louvers (1) for stiffness or binding. 2. Remove, inspect, clean, repair, and lubricate louver as necessary. 3. Place louver aside and reinstall after Item No. 4. |
| 2 | Conditioned Air Filter | <ol style="list-style-type: none"> 1. Remove, clean, inspect, and service the filter (2). 2. Discard and replace filter (2), if damaged. 1. Place filter aside and reinstall after Item No. 4. |

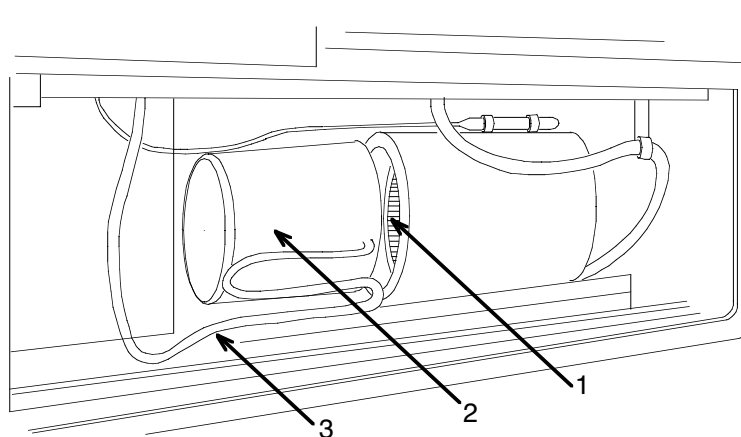

- | | | |
|---|--|---|
| 3 | Conditioned Air (Evaporator) Fan and Motor | <ol style="list-style-type: none"> 1. Wipe dust or dirt from the fan (1), motor (2), and all other components and surfaces in the area. 2. Inspect the fan (1) for damaged or bent blades; the motor (2) for signs of overheating; and all mounting hardware for tightness and security. 3. Inspect the wiring harness (3) for damage or chafing and all electrical connections for tightness. |
|---|--|---|

ITEM NO.	ITEMS TO BE INSPECTED/SERVICED	PROCEDURES
----------	--------------------------------	------------

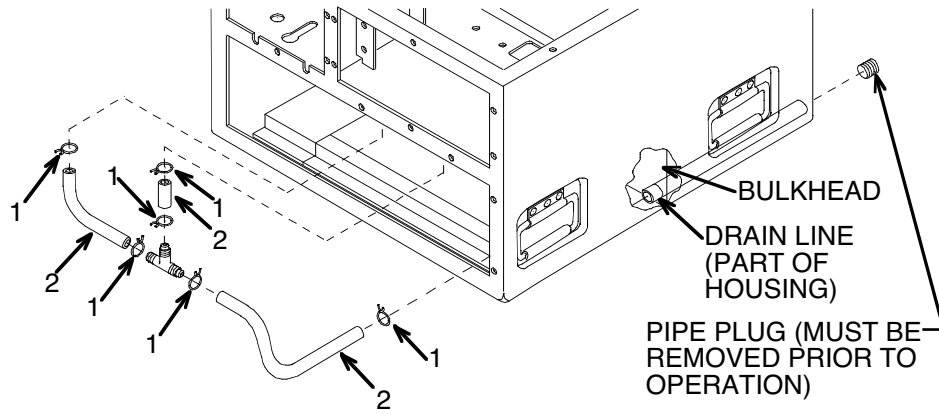

- | | | |
|---|-------------------------|--|
| 4 | Condensate Drain Tubing | <ol style="list-style-type: none"> 1. Check for loose connections, missing clamps (1), indications of water leaks, and damaged or missing tubing (2). 2. Repair or replace as indicated. 3. Install filter and return air louver. |
|---|-------------------------|--|

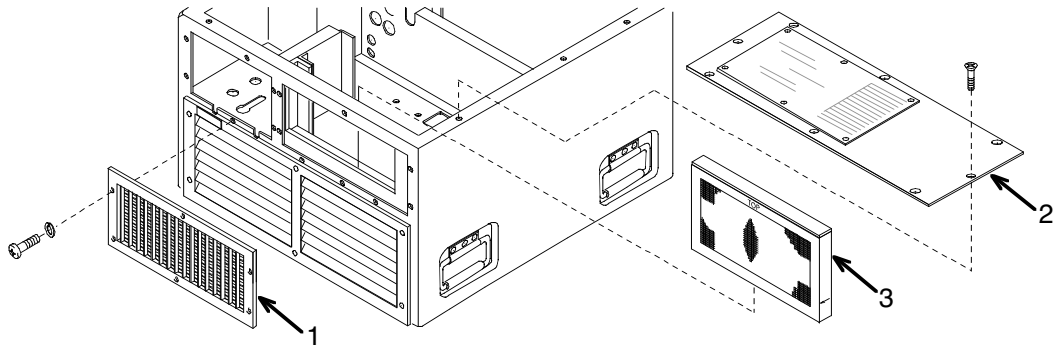

- | | | |
|---|-------------------------------|--|
| 5 | Conditioner Air Supply Louver | <ol style="list-style-type: none"> 1. Check louver for stiffness or binding. 2. Remove, clean, inspect, repair, and lubricate as necessary. 3. Set aside and reinstall after Item No. 6. |
| 6 | Mist Eliminator | <ol style="list-style-type: none"> 1. Remove, clean, and inspect the top-front panel (2). Set aside and reinstall after Item No. 8. 2. Remove, clean, inspect, and service the mist eliminator (3). 3. Replace the mist eliminator (3) if it is damaged in any way. 4. Set aside and reinstall after Item No. 8. |

ITEM NO.	ITEMS TO BE INSPECTED/SERVICED	PROCEDURES
----------	-----------------------------------	------------

WARNING

Compressed air used for cleaning purposes should not exceed 30 psi (2.1 kg/cm²)

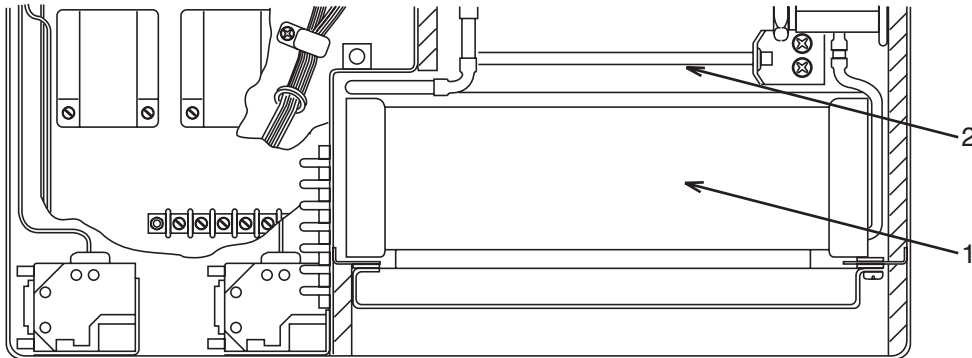

- | | | |
|---|------------------|--|
| 7 | Evaporator coil | <ol style="list-style-type: none"> 1. Using compressed air, blow accumulated dust and dirt out of air passages in the evaporator coil (1). Blow from front to back, in opposite direction from the operational airflow. 2. Inspect coil (1) for damage and check mounting hardware for tightness and security. Straighten any bent fins. |
| 8 | Heating elements | <ol style="list-style-type: none"> 1. Wipe any remaining dust or dirt from the heating elements (2), heater thermostat, and all other components or surface in the area. |

NOTE

Use a clean, dry cloth (or a slightly moistened cloth) when wiping the unit. NEVER use an oily or greasy cloth; residue left on any surface will attract and accumulate much more dust and dirt than dry surfaces.

2. Inspect the heating elements (2) and thermostat for obvious damage and all mounting hardware for tightness and security.
3. Inspect wiring harness for damage or chafing and all electrical connections for tightness.
4. Install mist eliminator, conditioned air supply louver, and the top-front panel.

ITEM NO.	ITEMS TO BE INSPECTED/SERVICED	PROCEDURES
----------	--------------------------------	------------

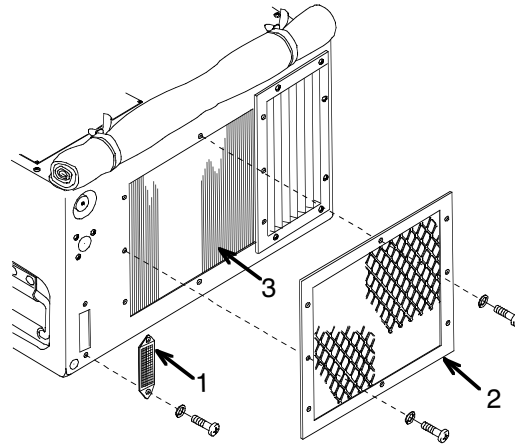

- | | | |
|----|-----------------------------|---|
| 9 | Fresh Air Ventilation Guard | <ol style="list-style-type: none"> 1. Remove, clean, and inspect the ventilation guard (1). 2. If damaged, discard and replace with a new one. 3. Reinstall the ventilation guard (1) to the unit. |
| 10 | Condenser Air Inlet Guard | <ol style="list-style-type: none"> 1. Remove, clean, and inspect the inlet guard (2). 2. Place inlet guard (2) aside and reinstall after Item No. 14. |

WARNING

Compressed air that is used for cleaning purposes should not exceed 30 psi (2.1 kg/cm²).

- | | | |
|----|----------------|---|
| 11 | Condenser coil | <ol style="list-style-type: none"> 1. Using compressed air, blow accumulated dust and dirt out of the air passages in the condenser coil (3). 2. Inspect both the condenser coil (3) for damage and all mounting hardware for tightness and security. Straighten any bent fins. |
|----|----------------|---|

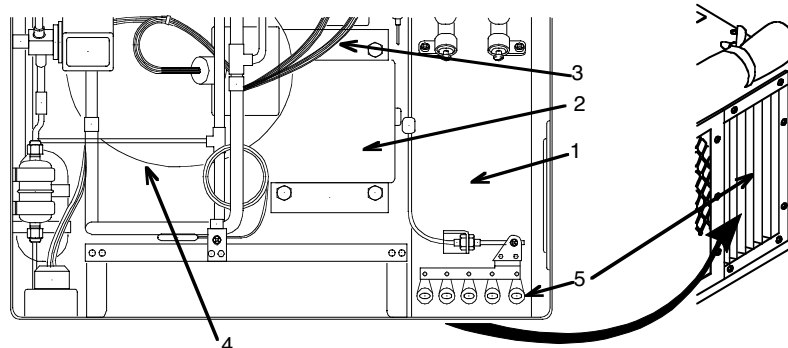

ITEM NO.	ITEMS TO BE INSPECTED/SERVICED	PROCEDURES
12	Condenser Fan and Motor	<ol style="list-style-type: none"> 1. Wipe dust or dirt from the fan (1), the motor (2), and all other components and surfaces in or around the area. 2. Inspect the fan (1) for damage or bent blades; the motor (2) for signs of over-heating; and all of the mounting hardware for tightness and security. 3. Inspect both the wiring harness (3) for damage or chafing and all of the electrical connections for tightness.
13	Compressor	<ol style="list-style-type: none"> 1. Wipe dust or dirt from both the compressor canister (4) and all remaining components and surfaces in the lower section of the cabinet. 2. Inspect the compressor crankcase heater element for signs of over-heating or deterioration. 3. Inspect both the wiring harness for damage or chafing and all of the electrical connections for tightness. 4. Check all mounting hardware for damage or chafing.
14	Condenser Discharge Air Louver and Actuator	<ol style="list-style-type: none"> 1. Check all mounting hardware and linkage connections for tightness. 2. Clean and lubricate as necessary. 3. Install the condenser air inlet guard and the top-rear panel.
15	Panels, Nameplates, and Housing	<ol style="list-style-type: none"> 1. Wipe all surfaces clean. 2. Check that all wiring and instruction plates are legible and in place. 3. Replace illegible or missing plates. 4. Check that all panels are in place. Make sure there is no dents, breaks, or other damages considered hazardous or otherwise interfere with the operation of the unit.

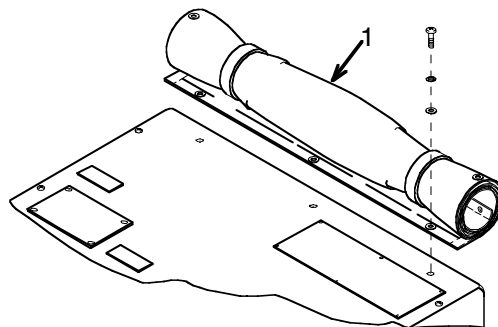

ITEM NO.	ITEMS TO BE	PROCEDURES
INSPECTED/SERVICED		
16	Fabric Cover	<ol style="list-style-type: none">1. Roll the fabric cover (1) down and inspect for tears, cracks, or any other signs of damage or deterioration.2. If necessary, wash the fabric cover using fresh water and a small amount of mild detergent.3. Allow fabric cover to dry, then roll up and secure the cover in the stowed position.

CAUTION

Do not check operation in the COOL mode until after the input power has been reconnected to the unit for a sufficient amount of time. This is done to eliminate any danger of liquid refrigerant accumulation in the compressor. Under moderate conditions, if input power has been disconnected, allow for a four-hour warm-up period. If air conditioner has been exposed to below freezing temperatures without input power, an eight-hour warm up period is recommended.

17	Operational Checks	<ol style="list-style-type: none">1. Be sure the MODE SELECTOR switch is in the OFF position. Reconnect input power.2. Perform function checks on the air conditioner in all operational modes.3. Set the air conditioner for its desired operational mode.4. Record the performance of quarterly PMCS, including all corrective actions taken.
----	--------------------	--

END OF WORK PACKAGE

UNIT MAINTENANCE
AIR CONDITIONER, HORIZONTAL, COMPACT
(NSN 4120-01-502-1319)
FABRIC COVER REMOVAL, CLEANING, AND INSTALLATION

INITIAL SETUP:**Tools**

Refrigeration Unit Service Tool Kit
 (WP 0092 00, Item 1)
 Scrub Brush (WP 0092 00, Item 2)

Materials/Parts

Fabric Cover
 Lock Washers (3)
 Detergent (WP 0094 00, Item 15)

REMOVAL

1. Unsnap four snap fasteners (2).
2. Remove three sets of machine screws (3), lock washers (4), and flat washers (5). Lift fabric cover (1) from the unit.

CLEANING

1. Wash the fabric cover using a solution of fresh water and mild detergent. A soft-scrubbing brush may be used to remove caked deposits. Thoroughly rinse with fresh water and air dry.
 - a) Check the fabric cover (1) for cuts, tears, and damaged or missing screw eyelets or snap fasteners and replace cover if damaged.

INSTALLATION

2. Secure the fabric cover (1) to the unit with three sets of machine screws (3), lock washers (4), and flat washers (5).
 1. (If the unit is to be put back in service) Roll fabric cover (1) up and tie in place.
 2. (If unit is to be stored or shut down) Roll fabric cover (1) down and secure the cap, snap fasteners (2).

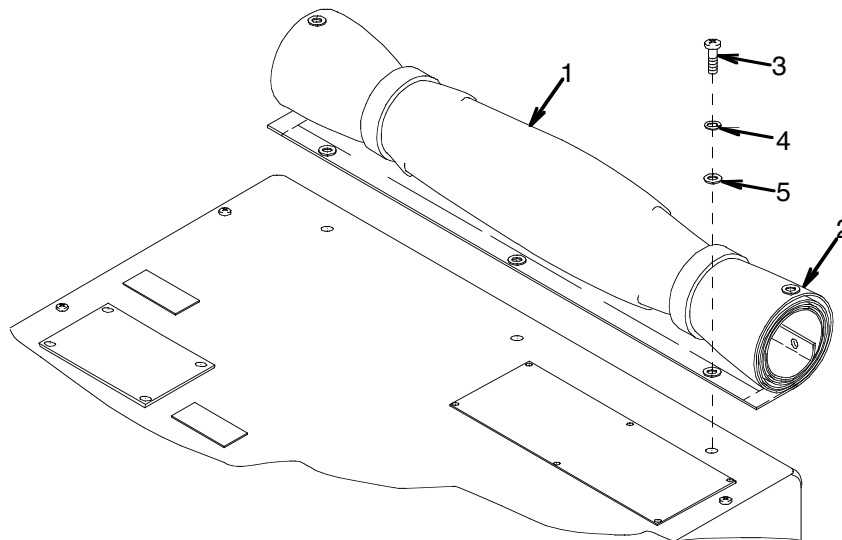
**END OF WORK PACKAGE**

UNIT MAINTENANCE
AIR CONDITIONER, HORIZONTAL, COMPACT
(NSN 4120-01-502-1319)
TOP PANEL REMOVAL, CLEANING, AND INSTALLATION

INITIAL SETUP:**Tools And Special Tools**

Refrigeration Unit Service Tool Kit
 (WP 0092 00, Item 1)
 Scrub Brush (WP 0092 00, Item 2)

Materials/Parts

Dry Cleaning Solvent (WP 0094 00, Item 3)

Rags (WP 0094 00, Item 13)
 Detergent (WP 0094 00, Item 15)

Equipment Conditions

Disconnect power at the power source.
 Remove Fabric Cover (WP 0015 00)

REMOVAL**NOTE**

The top rear panel (4) and the access panel (13) can be removed independently. The top-center panel (9) must be removed last.

1. Remove eight screws (1) and the top-front panel (2).
2. Remove seven screws (3) and the top-rear panel (4).

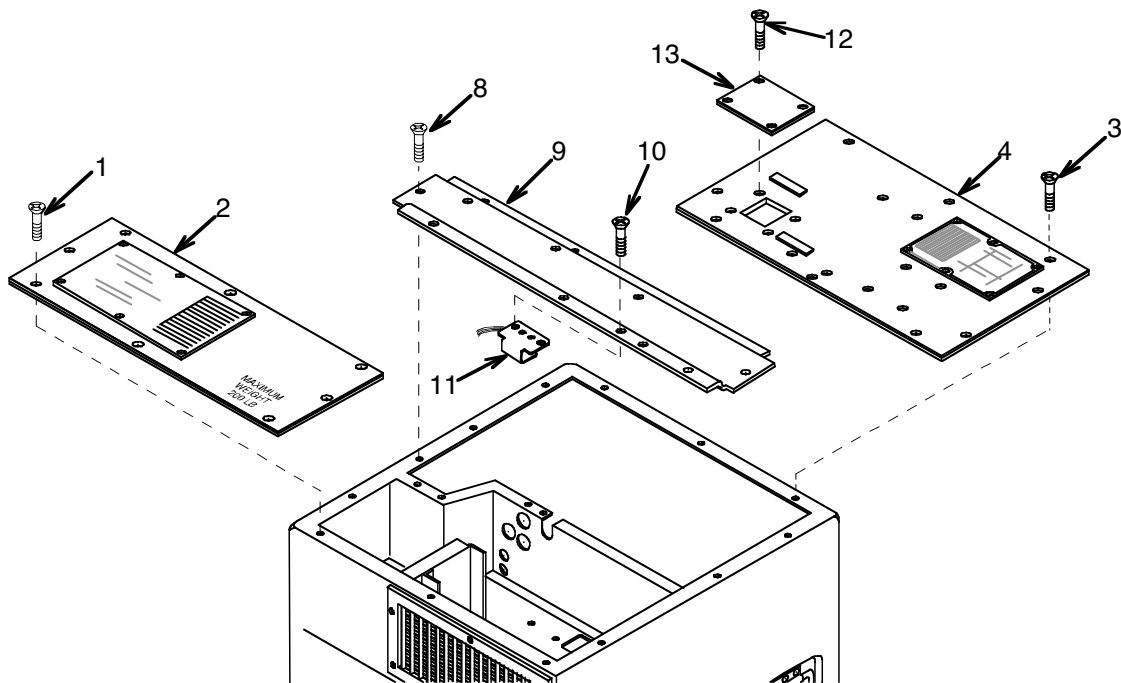

3. Remove six screws (8) and the top-center panel (9).
4. Carefully raise the top-center panel (9) and remove two screws (10) and the heater cutout switch bracket (11).
5. Remove four screws (12) and access panel (13).

CLEANING**WARNING**

Do not use near an open flame or excessive heat. Dry cleaning solvent that is used to clean parts is potentially dangerous to personnel and property.

Clean the panels with a rag dampened with a detergent solution or a dry cleaning solvent. If necessary, use a soft brush to dislodge any caked on dirt. Be sure to dry items thoroughly.

INSTALLATION

1. Secure the access panel (13) to the top-rear panel (4) with four screws (12).
2. Secure the heater cutout switch bracket (11) to the top-center panel (9) with two screws (10).
3. Install the top-center panel (9) with six screws (8).
4. Install the top-rear panel (4) with seven screws (3).
5. Install the top-front panel (2) with eight screws (1).
6. Install fabric cover (WP 0018 00).
7. Connect power at the power source.

END OF WORK PACKAGE

UNIT MAINTENANCE
AIR CONDITIONER, HORIZONTAL, COMPACT
(NSN 4120-01-502-1319)
REAR SCREEN AND GUARD CLEANING AND REPLACEMENT

INITIAL SETUP:**Tools And Special Tools**

Refrigeration Unit Service Tool Kit
 (WP 0092 00, Item 1)
 Scrub Brush (WP 0092 00, Item 2)

Materials/Parts

Dry Cleaning Solvent (WP 0094 00, Item 3)

Rags (WP 0094 00, Item 13)
 Detergent (WP 0094 00, Item 15)
 Lock Washers (10)

Equipment Conditions

Disconnect power at the power source.
 Remove Fabric Cover (WP 0015 00)

REMOVAL

1. Remove two screws (1), lock washers (2), and the fresh-air ventilation screen (3).
2. Remove two screws (4) and lock washers (5) from the horizontal frames of the condenser air inlet screen (6).
3. Remove six screws (7), lock washers (8), and condenser air inlet screen (6).

NOTE

The six screws (7) on the vertical frame of the condenser air inlet screen also secure the condenser coil to the air conditioner housing.

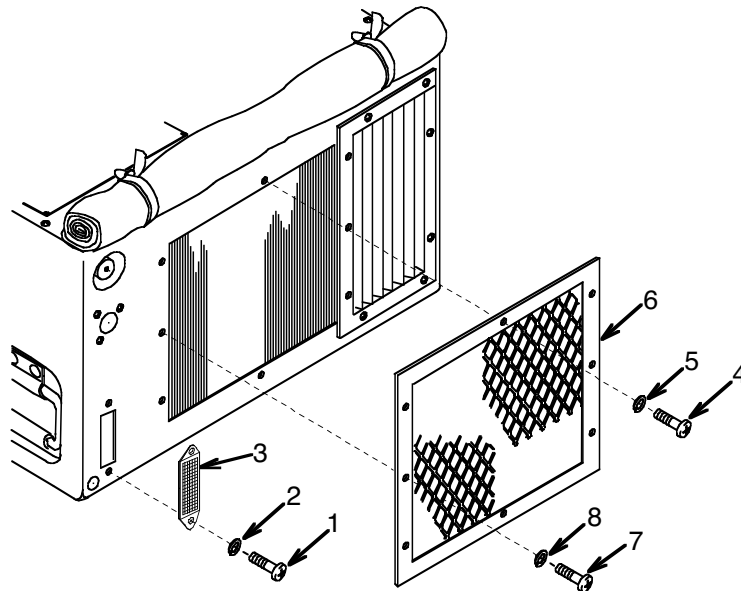

CLEANING**WARNING**

Do not use near an open flame or excessive heat. Dry cleaning solvent that is used to clean parts is potentially dangerous to personnel and property.

1. When necessary, wipe or brush dirt from the screens.
2. If screens are extremely dirty, clean with a detergent solution or dry cleaning solvent.

INSTALLATION**NOTE**

The six screws (7) on the vertical frames of the condenser air inlet screen also secure the condenser coil to the air conditioner housing.

1. Install the condenser air inlet screen (6) using six screws (7) and lock washers (8).
2. Install two screws (4) and lock washers (5).
3. Install the fresh air ventilation screen (3) using two screws (1) and lock washers (2).
4. Connect power at power source.

END OF WORK PACKAGE

UNIT MAINTENANCE
AIR CONDITIONER, HORIZONTAL, COMPACT
(NSN 4120-01-502-1319)

RETURN AIR LOUVER AND AIR FILTER REMOVAL, CLEANING, INSPECTION, AND INSTALLATION

INITIAL SETUP:

Tools

Refrigeration Unit Service Tool Kit (WP 0092 00, Item 1)
 Scrub Brush (WP 0092 00, Item 2)

Materials/Parts

Dry Cleaning Solvent (WP 0094 00, Item 3)
 Rags (WP 0094 00, Item 13)
 Detergent (WP 0094 00, Item 15)
 Lock Washers (8)
 Air Filter Coater (WP 0094 00, Item 1)

Equipment Condition

Disconnect power at the power source.

General Instructions

Dry cleaning solvent used to clean parts is potentially dangerous to personnel and property. Do not use near open flame or excessive heat. Use in well ventilated area.

WARNING

Do not use near an open flame or excessive heat. Dry cleaning solvent that is used to clean parts is potentially dangerous to personnel and property.

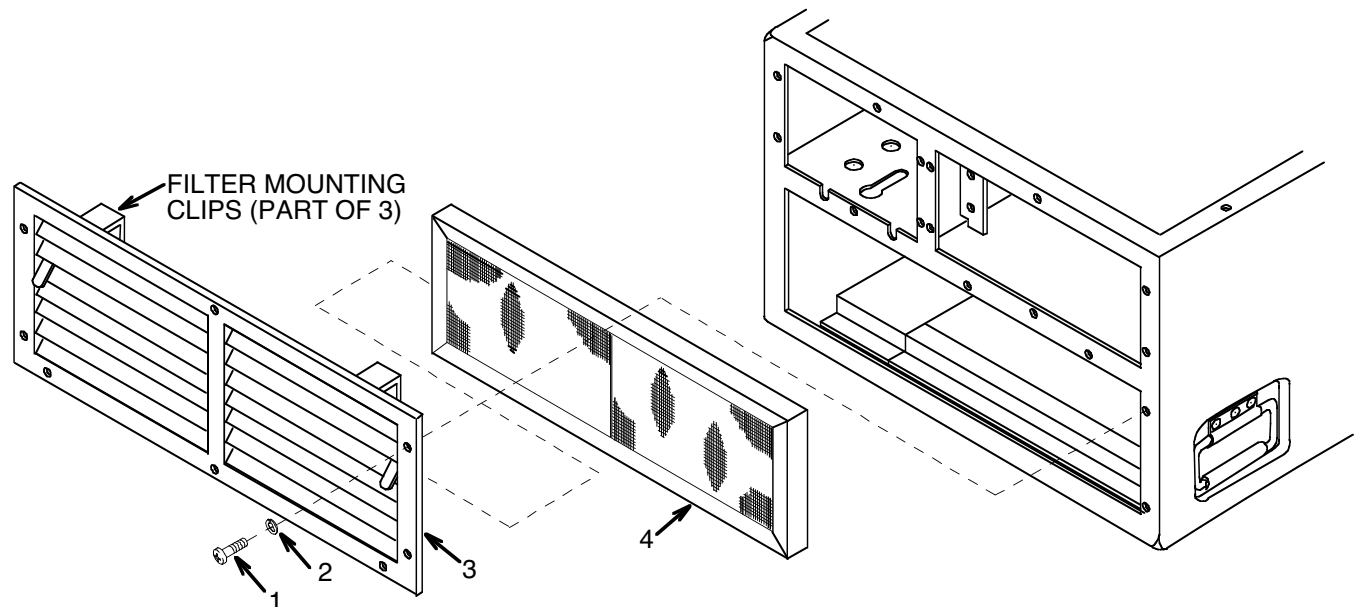

REMOVAL

1. Remove eight screws (1) and lock washers (2) and then pull louver (3) from the unit.
2. Remove filter (4) from the clips on the back of louver.

WARNING

Do not use near an open flame or excessive heat. Dry cleaning solvent that is used to clean parts is potentially dangerous to personnel and property.

CLEANING

1. When necessary, wipe or brush dirt from the louver. If louver is extremely dirty, it may be washed following the same process as the filter.
2. Immerse the filter in a mild detergent solution or dry cleaning solvent.
3. Agitate until dirt is removed, using a soft brush to loosen caked-on dirt.
4. Rinse in clean water.
5. Drain, then hold the filter horizontal and tap each edge on a bench or the floor to remove any excess water droplets.
6. Be sure the filter is completely dry prior to installation.

INSPECTION

1. Check the filter (4) for punctures, cuts, or damaged edges that allow for passage of unfiltered air.
2. Check the filter (4) for packed or mashed areas that would block the airflow.
3. Replace the filter (4) if necessary.

INSTALLATION

1. Airflow arrows should point away from louver.
2. Place the filter (4) in retainer clips.
3. Secure the louver (3) with eight screws (1) and lock washers (2).

NOTE

FOLLOW-ON MAINTENANCE:
Connect power at the power source.

END OF WORK PACKAGE

UNIT MAINTENANCE
AIR CONDITIONER, HORIZONTAL, COMPACT
(NSN 4120-01-502-1319)
SUPPLY AIR LOUVER REMOVAL, CLEANING, AND INSTALLATION

INITIAL SETUP:**Tools**

Refrigeration Unit Service Tool Kit (WP 0092 00, Item 1)
 Scrub Brush (WP 0092 00, Item 2)

Rags (WP 0094 00, Item 13)
 Detergent (WP 0094 00, Item 15)
 Lock Washers (2)

Materials/Parts

Dry Cleaning Solvent (WP 0094 00, Item 3)

Equipment Condition

Disconnect power at the power source.
 Remove Fabric Cover (WP 0015 00)

REMOVAL

1. Remove six screws (1) and lock washers (2) and pull the louver (3) from the unit.

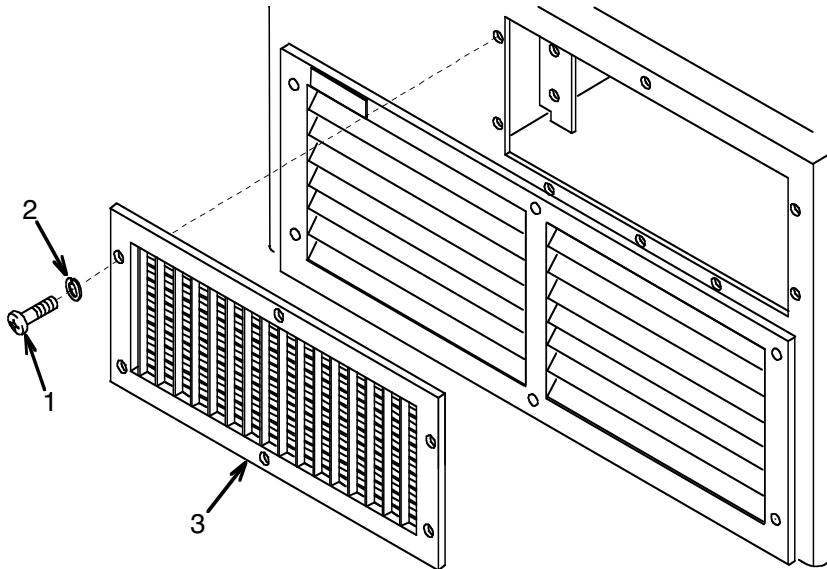
**WARNING**

Do not use near an open flame or excessive heat. Dry cleaning solvent that is used to clean parts is potentially dangerous to personnel and property.

CLEANING

4. Wipe or brush dirt from the louver.
5. If the louver is extremely dirty, immerse in a detergent solution or dry cleaning solvent.
6. If necessary, scrub louver with a soft brush until caked-on dirt is removed
7. Rinse the louver in clean water or clean dry cleaning solvent.
8. Dry thoroughly.

INSTALLATION

Secure the louver (3) with screws (1) and lock washers (2).

NOTE

FOLLOW-ONMAINTENANCE:
Connect power at the power source
Install Fabric Cover (WP 0015 00)

END OF WORK PACKAGE

UNIT MAINTENANCE
AIR CONDITIONER, HORIZONTAL, COMPACT
(NSN 4120-01-502-1319)
INFORMATION PLATES INSPECTION AND REPLACEMENT

INITIAL SETUP:**Tools**

Refrigeration Unit Service Tool Kit (WP 0092 00, Item 1)
Scrub Brush (WP 0092 00, Item 2)

Equipment Condition

Disconnect power at the power source.
Remove Fabric Cover (WP 0015 00)

Materials/Parts

Dry Cleaning Solvent (WP 0094 00, Item 3)
Detergent (WP 0094 00, Item 15)

INSPECTION

Replace any plate that is damaged, missing, or illegible.

CAUTION

Metal shavings can damage electrical components. The removal of panels is necessary prior to drilling.

REMOVAL

1. Remove panels as necessary to access rivets.
2. Remove old plates, using a drill stop to avoid damage to internal parts.

INSTALLATION

1. Install new plates.
2. Install panels.

NOTE

FOLLOW-ON MAINTANENCE:
Connect power at the power source
Install Fabric Cover (WP 0015 00)

END OF WORK PACKAGE

UNIT MAINTENANCE
AIR CONDITIONER, HORIZONTAL, COMPACT
(NSN 4120-01-502-1319)
MIST ELIMINATOR REPLACEMENT, CLEANING, AND INSPECTION

INITIAL SETUP:**Tools**

Refrigeration Unit Service Tool Kit (WP 0092, Item 1)
 Scrub Brush (WP 0092 00, Item 2)

Equipment Condition

Disconnect power at the power source.
 Remove Fabric Cover (WP 0015 00).

Materials/Parts

Dry Cleaning Solvent (WP 0094 00, Item 3)
 Detergent (WP 0094 00, Item 15)

WARNING

Do not use near an open flame or excessive heat. Dry cleaning solvent that is used to clean parts is potentially dangerous to personnel and property.

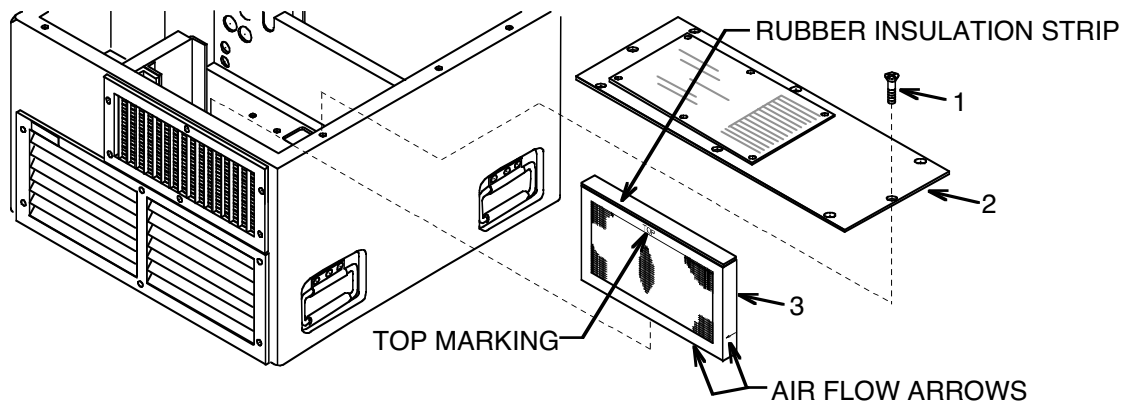
**REMOVAL**

1. Remove eight screws (1) and the top front panel (2).
2. Pull mist eliminator (3) up and out of the mounting frame.

WARNING

Do not use near an open flame or excessive heat. Dry cleaning solvent that is used to clean parts is potentially dangerous to personnel and property.

CLEANING

1. Immerse the part in a detergent solution or a dry cleaning solvent.
2. Scrub the part using a soft brush, if necessary, to loosen caked-on dirt.

Cleaning - Continued

3. Rinse the part in clean water.
4. Drain, then tap each end of the part to dislodge any droplets of water.

INSPECTION

1. Check the mist eliminator (3) for punctures, cuts, and damaged edges that would allow air to bypass.
2. Check the mist eliminator (3) for packed or mashed areas that would block airflow.
3. If necessary, replace mist eliminator (3).

INSTALLATION

1. TOP marking must be up and airflow arrows (located on the side or bottom) must point outward, away from the coil.
2. Slide the mist eliminator (3) down into the mounting frames while observing the airflow arrows and TOP marking.
3. Install the top front panel (2) and secure with eight screws (1).

NOTE

FOLLOW-ON MAINTANENCE:
Connect power at the power source
Install Fabric Cover (WP 0015 00).

END OF WORK PACKAGE

UNIT MAINTENANCE
AIR CONDITIONER, HORIZONTAL, COMPACT
(NSN 4120-01-502-1319)
CONDENSER AIR DISCHARGE LOUVER AND LINKAGE CLEANING, INSPECTION, REMOVAL AND
INSTALLATION

INITIAL SETUP:**Tools**

Refrigeration Unit Service Tool Kit (WP 0092, Item 1)
Scrub Brush (WP 0092 00, Item 2)

Materials/Parts

Detergent (WP 0094 00, Item 15)
Rags (WP 0094 00, Item 13)

Lock Washer (4)
Cotter Pins (5)

Equipment Condition

Disconnect power at the power source.
Remove top panels (WP 0016 00)
Remove condenser air inlet screen (WP 0017 00)

WARNING

Do not tamper with the cylinder of the refrigerant tubing connections. If the actuating cylinder is suspected to be bad, notify your supervisor.

CLEANING

Clean the louver assembly with a soft brush or wash with water and a mild detergent solution.

INSPECTION

1. Check louver for bent louver blades (6), missing or damaged gaskets, and missing hardware or bearings.
2. Clean the linkage with a soft brush and damp rag.
3. Check push-pull cable attaching hardware (mechanical post and screws etc.) for tightness.

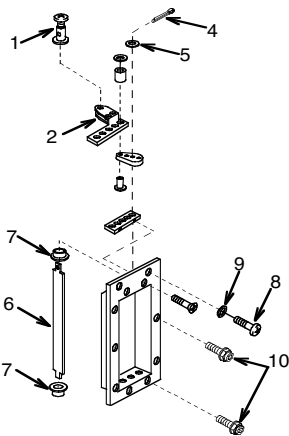
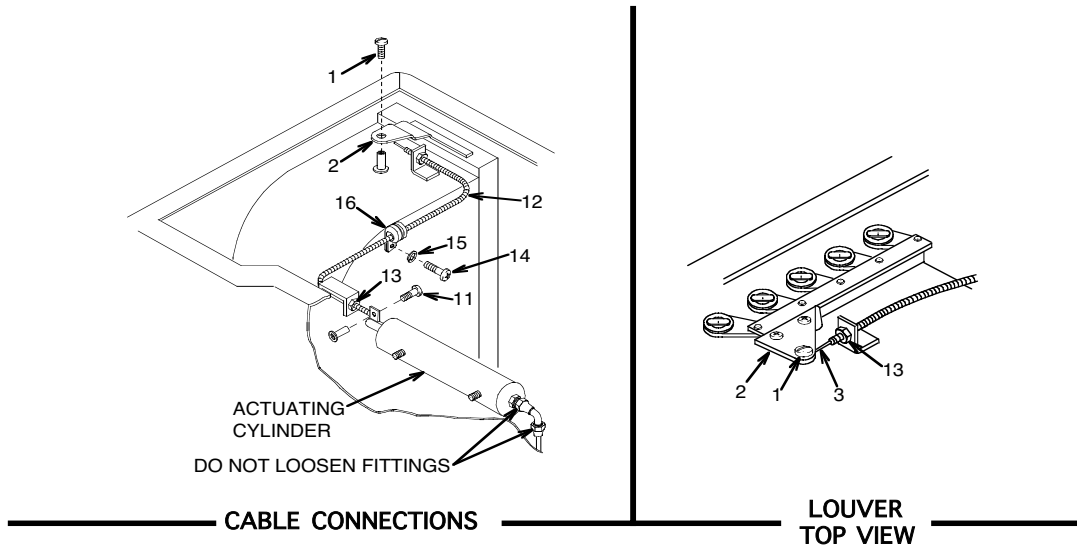

4. If unit has been operating, wait until it has cooled to ambient temperature for approximately four hours.
5. Loosen mechanical post screw (1) on the louver-connecting link (2).
6. Close louvers.
7. Pull wire (3) tight with needle nose pliers and tighten mechanical post screw (1).
8. Ensure that the louvers are tightly closed.

REPLACEMENT

WARNING

Do not tamper with the cylinder or refrigerant tubing connections. Notify your supervisor if you suspect the actuating cylinder is bad.

NOTE

Individual louver blades are flexible enough for removal.

To replace the louver blade:

1. Remove cotter pin (4) and flat washers (5) from louver blade (6) to be removed.
2. Flex or spring the louver blade (6) to remove ends from the louver blade bearings (7).
3. Remove louver blade (6).
4. Replace louver blade bearings (7) if they are damaged.
5. Flex or spring new louver blade (6) and install.
6. Install flat washers (5) and cotter pin (4).

REMOVAL**To remove the louver, linkage assembly, and cable:**

1. Loosen mechanical post screw (1) and pull the push-pull control cable wire (3) from the louver-connecting link (2).
2. Remove four machine screws (8) and lock washers (9) and two snap fastener studs (10).
3. Slide louver assembly from unit.
4. Loosen mechanical post screw (11) and pull push-pull control cable wire (12) from actuating cylinder.
5. Remove nuts (13) from each end of the cable (12).
6. Remove screw (14), lock washer (15), and clamp (16) from cable (12).
7. Replace any damaged parts.

INSTALLATION**To install the louver, linkage assembly, and cable:**

1. Install screw (14), lock washer (15), and clamp (16) onto the cable (12).
2. Install nuts (13) 1/2 inch from each end of cable (12). Do not tighten.
3. Insert cable (12) into retaining brackets.
4. Tighten nuts (13) on each end of cable (12).
5. Slide louver assembly into unit and secure with four machine screws (8), lock washers (9), and two snap fastener studs (10).
6. Insert the push-pull control cable wire end through the mechanical post (1).
7. Insert end of wire through mechanical post (11) and tighten screw (11) at actuating cylinder end.
8. Close louvers and pull control cable wire (3) tight with needle nose pliers and tighten mechanical post screw (1).

NOTE

FOLLOW-ON MAINTENANCE:
Install the top panels (WP 0016 00)
Install the condenser air inlet screen (WP 0017 00)

END OF WORK PACKAGE

UNIT MAINTENANCE
AIR CONDITIONER, HORIZONTAL, COMPACT
(NSN 4120-01-502-1319)
FRESH AIR DAMPER AND ACTUATOR CLEANING AND INSPECTION

INITIAL SETUP:**Tools**

Refrigeration Unit Service Tool Kit (WP 0092 00, Item 1)

Equipment Condition

Remove the supply air louver (WP 0019 00)
 Remove the Return Air Louver and Air Filter (WP 0018 00)

Materials/Parts

Rags (WP 0094 00, Item 13)

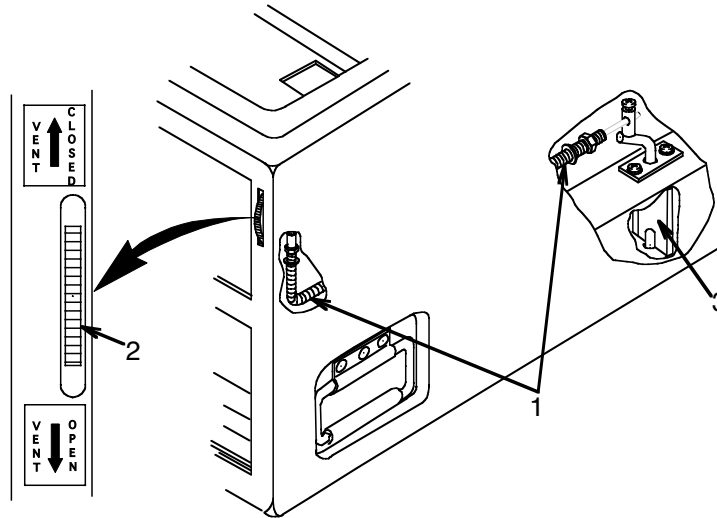
**CLEANING**

Wipe loose any dirt from the controls and linkages with a clean cloth.

INSPECTION

1. Check the push-pull control assembly (1) for operation by turning the actuator plate wheel (2).
2. Check that the ventilation damper (3) moves when the actuator plate (2) is turned.

NOTE

FOLLOW-ON MAINTENANCE:
 Install the return air louver (WP 0018 00)
 Install supply air louver (WP 0019 00)

END OF WORK PACKAGE

UNIT MAINTENANCE
AIR CONDITIONER, HORIZONTAL, COMPACT
(NSN 4120-01-502-1319)
CONDENSATE DRAIN INSPECTION, CLEANING, AND REPLACEMENT

INITIAL SETUP:**Tools**

Refrigeration Unit Service Tool Kit
 (WP 0092 00, Item 1)

Equipment Condition

Remove the return air louver (WP 0018 00)

Materials/Parts

Tubing (WP 0093 00, Item 6)
 Tee Connector

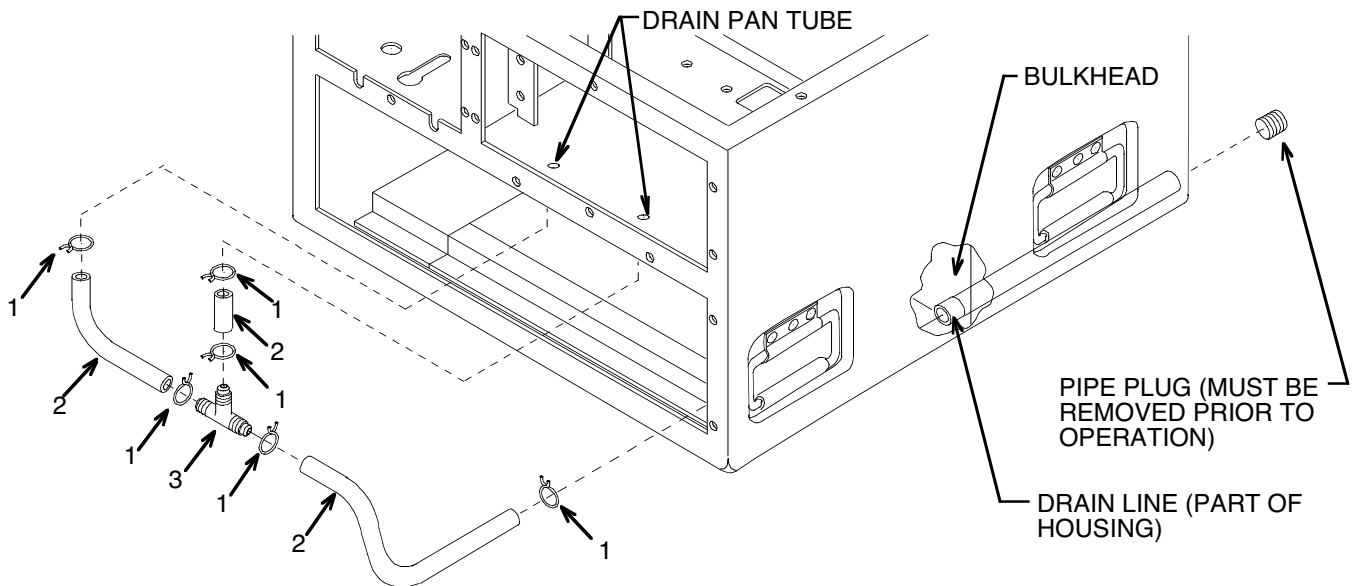
**REMOVAL**

1. Remove hose and wire clamps (1).
2. Pull nonmetallic tubing (2) loose from connection points
3. Pull nonmetallic tubing (2) loose from hose tee connector (3) in drain pan and housing.

INSPECTION

1. Check nonmetallic tubing (2) for cuts, splits, and deteriorated condition.
2. Check that aluminum tube from the bulkhead to the rear of the unit is not clogged.
3. Check that the hose tee connector (3) is not clogged.

CLEANING

1. Clean drain tubes in the bottom of the drain pan.
2. Clean the aluminum tube that runs from bulkhead to rear of unit.
3. Clean the hose tee connector (3).
4. Flush tubes and tee connector with clean water.

REPLACEMENT

Replace the damaged tubing or tee connection that is found during inspection.

INSTALLATION

1. Slide the hose and wire clamps (1) onto nonmetallic tubes (2).
2. Slip nonmetallic tubing (2) onto the hose tee connector (3). Tighten the hose and wire clamps (1).
3. Slip nonmetallic tubing (2) onto connection points in drain pan and housing. Tighten the hose, wire clamps (1).

NOTE

FOLLOW-ON MAINTANENCE:
Install the Return Air Louver (WP 0018 00)

END OF WORK PACKAGE

UNIT MAINTENANCE
AIR CONDITIONER, HORIZONTAL, COMPACT
(NSN 4120-01-502-1319)
ELECTRICAL WIRING REPAIR

INITIAL SETUP:**Tools**

Refrigeration Unit Service Tool Kit (WP 0092 00, Item 1)
 Soldering Gun Kit
 Crimping Tool Kit
 Heat Gun (WP 0092 00, Item 4)

Materials/Parts

Wire
 Insulation Tape (WP 0094 00, Item 18)
 Solder (WP 0094 00, Item 7)
 Flux (WP 0094 00, Item 6)

REPAIR**1. Soldering Connections.**

Wire connections must be made mechanically sound before they are soldered; solder alone does not provide sufficient strength to prevent breakage. Joining surfaces of connections to be soldered must be clean and bright. Flux should be brushed onto the joint before soldering. Wires should always be heated to the point at which the solder will melt completely and flow into all parts of the joint. Excessive build-up of solder "gobs" on the joint should be avoided or removed.

2. Insulating Joints.

The preferred method of insulating electrical joints is by the use of heat-shrink tubing. To apply, cut a piece of heat-shrink tubing of suitable diameter to a length of 1 inch (2.5 cm) for covering joints at terminals or connectors, or to a length about 1/2 inch (1.3 cm) longer than the joint to be insulated. Slide the tubing over the wire before making the joint. After the joint is made, slide the tubing so that it covers the joint, and shrink in place with moderate heat.

3. Splicing Wires.

To repair broken or cut wires that are otherwise sound, the mating ends can be stripped and spliced. A commercial butt splice can be crimped onto the ends to joint them, or a "Western Union" wire splice can be made. The latter is made by stripping 1/4 - 1/2 inch (0.6 -1.3 cm) of insulation from the wire ends, and sliding on a piece of insulation tubing as described above. Hold the ends parallel and facing opposite directions, then twist each end around the other wire at least three turns. Solder and apply insulation as described above.

4. Crimping Terminals.

To install a terminal on the end of a wire, strip 1/4 - 1/2 inch (0.6 -1.3 cm) of insulation from the end of the wire, apply a one-inch (2.5 cm) piece of heat-shrink tubing (if the terminals are of the non-insulated type). Insert wire-end into the shank of the terminal. Crimp the shank and install heat-shrink tubing, if necessary.

NOTE

Preferred repair methods consist of replacing wires, terminals, connectors, ect., rather than splicing wires, bending ends to form terminals, and other makeshift procedures. Although some methods may be appropriate for emergency field repairs, determine the proper size and length of the wire, the terminal, or the connector to be used for replacement by referring to Table 1, Wire List, located in this work package.

Table 1. Wire List.

TERMINATION		TERMINATION		AGW WIRE	LENGTH	
FROM	TERMINAL TYPE	TO	TERMINAL TYPE	SIZE	IN.	CM
LOOSE WIRES						
S1-12	13216E6191-1	S3-3	MS25036-149	20	10	25.4
S 1-11	13216E6191-1	S3-1	MS25036-149	20	7	17.8
S 1-2C	13216E6191-1	S2-A2	13216E6191-1	20	7	17.8
S 1-2B	13216E6191-1	S2-B2	13216E6191-1	20	9	22.9
S 1-3C	13216E6191-1	S2-C2	13216E6191-1	20	8	20.3
S 6-4	MS25036-108	S6-2	MS25036-108	16	2	5.1
S 6-3	MS25036-108	TB2-9	13216E6191-2	16	18	45.7
S 6-1	MS25036-108	TB2-7	13216E6191-2	16	18	45.7
S 6-2	MS25036-108	TB2-8	13216E6191-2	16	18	45.7
AUXILLIARY POWER CABLE ASSEMBLY						
J11-A	MS3100R18-11P	P6-A	MS3106R18-11S	12	40	101.6
J11-B	MS3100R18-11P	P6-B	MS3106R18-11S	12	40	101.6
J11-C	MS3100R18-11P	P6-C	MS3106R18-11S	12	40	101.6
J11-D	MS3100R18-11P	P6-D	MS3106R18-11S	12	40	101.6
COMPRESSOR WIRING HARNESS						
P4-A	MS2106R20-15P	P10-A	MS2106R20-15S	12	22	55.9
P4-B	MS2106R20-15P	P10-B	MS2106R20-15S	12	22	55.9
P4-C	MS2106R20-15P	P10-C	MS2106R20-15S	12	22	55.9
P4-D	MS2106R20-15P	P10-D	MS2106R20-15S	20	22	55.9
P4-E	MS2106R20-15P	P10-E	MS2106R20-15S	20	22	55.9
P4-F	MS2106R20-15P	P10-F	MS2106R20-15S	16	22	55.9
P4-G	MS2106R20-15P	P10-G	MS2106R20-15S	16	22	55.9
TRANSFORMER AND RECTIFIER WIRING HARNESS						
T1-2		TB2-10	13216E6191-1	20	14	35.6
T1-5		TB2-11	13216E6191-1	20	14	35.6
CR1-2	13216E6191-1	TB2-12	13216E6191-1	20	14	35.6
T1-7		CR1-1	13216E6191-1	20	14	35.6
T1-8		CR1-3	13216E6191-1	20	14	35.6
CONTROL MODULE HARNESS						
P2A-1		S2-A1	13216E6191-2	16	9	22.9
P2A-2		S2-B1	13216E6191-2	16	9	22.9

TERMINATION		TERMINATION		AGW WIRE	LENGTH	
FROM	TERMINAL TYPE	TO	TERMINAL TYPE	SIZE	IN.	CM
P2A-3		S2-C1	13216E6191-2	16	9	22.9
P2A-4		S2-A3	13216E6191-1	20	10	25.4
P2A-5		S2-B3	13216E6191-1	20	10	25.4
P2A-6		S2-C3	13216E6191-1	20	10	24.4
P2A-7		S1-5	13216E6191-2	16	8	20.3
P2A-8		S1-9	13216E6191-2	16	9	22.9
P2A-9		S1-13	13216E6191-2	16	9	22.9
P2A-11		CB1-A1	13216E6191-3	16	7	17.8
P2A-11		S1-8	13216E6191-2	12	9	22.9
P2A-12		CB1-B1	13216E6191-3	16	7	17.8
P2A-12		S1-8	13216E6191-2	12	9	22.9
P2A-13		CB1-C1	13216E6191-3	16	7	17.8
P2A-13		S1-16	13216E6191-2	12	9	22.9
P2A-14		CB1-A2	13216E6191-3	12	10	25.4
P2A-15		CB1-B2	13216E6191-3	12	11	27.9
P2A-16		CB1-C2	13216E6191-3	12	11	27.9
P2B-3		S1-3	13216E6191-1	20	12	30.5
P2B-4		K6-87	13216E6191-1	20	11	27.9
P2B-5		S1-1	13216E6191-1	20	11	27.9
P2B-6		S1-10	13216E6191-2	16	7	17.8
P2B-7		CB1-C	13216E6192	20	11	27.9
P2B-8		CB1-NO	13216E6192	20	11	27.9
P2B-9		K6-86	13216E6191-1		11.0	27.9
P2B-10		S3-1	MS25036-149	20	12	30.5
P2B-11		E1	MS25036-153	16	7	17.8
S1-2		S3-3	MS25036-153	20	7	17.8
S1-4		S3-1	MS25036-153	20	7	17.8
S1-7		S2-A2	13216E6191-1	20	7	17.8
S1-11		S2-B2	13216E6191-1	20	6	15.3
S1-15		S2-C2	13216E6191-1	20	5	12.7
S1-2		K6-30	13216E6191-1	16	7	17.8
S1-3		K6-85	13216E6191-1	20	7	17.8
S1-11		S3-1		20	8	20.3

TERMINATION		TERMINATION		AGW WIRE	LENGTH	
FROM	TERMINAL TYPE	TO	TERMINAL TYPE	SIZE	IN.	CM
S1-12		S3-3		20	10	25.4
JUNCTION BOX HARNESS						
J2A-1		J3-A		16	22	55.9
J2A-2		J3-B		16	22	55.9
J2A-3		J3-C		16	22	55.9
J2A-4		J3-D		18	22	55.9
J2A-5		J3-E		18	22	55.9
J2A-6		J3-F		18	22	55.9
J2A-7		TB2-3	13216E6191-2	16	32	81.3
J2A-8		TB2-2	13216E6191-2	16	32	81.3
J2A-9		TB2-1	13216E6191-2	16	32	81.3
J2A-11		TB1-1	MS25036-156	12	18	45.7
J2A-12		TB1-2	MS25036-156	12	18	45.7
J2A-13		TB1-3	MS25036-156	12	18	45.7
J2A-14		K3-A1	MS25036-112	12	18	45.7
J2A-15		K3-B1	MS25036-112	12	18	45.7
J2A-16		K3-C1	MS25036-112	12	18	45.7
J2B-3		TB1-5	MS25036-149	20	18	45.7
J2B-4		J8-A		20	26	66.0
J2B-5		K2-X1	MS25036-149	20	18	45.7
J2B-6		CB2-1	MS25036-101	20	22	55.9
J2B7		K5-2		20	25	63.5
J2B-8		TB2-10	13216E6191-1	20	32	81.3
J2B-10		TB2-12	13216E6191-1	20	32	81.3
JB-11		E2	MS25036-153	16	20	50.8
J3-G		E4	MS25036-153	16	36	91.5
J4-A		K3-A2	MS25036-112	12	36	91.5
J4-B		K3-B2	MS25036-112	12	36	91.5
J4-C		K3-C2	MS25036-112	12	36	91.5
J4-D		J5-D		16	8	20.3
J4-E		S5-2	13216E6191-1	20	31	78.8
J4-F		K3-A1	MS25036-108	16	36	91.5

TERMINATION		TERMINATION		AGW WIRE	LENGTH	
FROM	TERMINAL TYPE	TO	TERMINAL TYPE	SIZE	IN.	CM
J4-G		K3-B1	MS25036-108	16	36	91.5
J5-A		K4-1		16	32	81.3
J5-B		K4-5		16	32	81.3
J5-C		K4-10		16	32	81.3
J5-E		TB1-6	MS25036-153	16	32	81.3
J5-G		E4	MS25036-153	16	32	81.3
J6-A		TB3-4	MS25036-156	12	15	38.1
J6-B		TB3-5	MS25036-156	12	15	38.1
J6-C		TB3-6	MS25036-156	12	15	38.1
J6-D		E3	MS25036-156	12	16	40.6
J8-B		K3-X2	MS25036-149	20	36	91.5
J9-A		K3-X2	MS25036-149	20	32	81.3
J9-B		K4-9		20	32	81.3
J1-A		TB3-1	MS25036-156	12	43	109.2
J1-B		TB3-2	MS25036-156	12	43	109.2
J1-C		TB3-3	MS25036-156	12	43	109.2
J1-D		E3	MS25036-156	12	43	109.2
TB1-1	MS25036-149	K5-A		20	16	40.6
TB1-1	MS25036-153	K2-A1	MS25036-108	16	16	40.6
TB1-2	MS25036-153	TB3-2	MS25036-153	16	36	91.5
TB1-2	MS25036-153	K2-B1	MS25036-108	16	16	40.6
TB1-2	MS25036-149	K5-B		20	16	40.6
TB1-3	MS25036	TB3-3	MS25036-156	12	36	91.5
TB1-3	MS25036-156	TB2-11	MS25036-156	12	36	91.5
TB1-3	MS25036-149	K5-C		20	16	40.6
TB1-3	MS25036-153	K2-C1	MS25036-108	16	17	43.2
TB1-4	MS25036	K4-2		16	16	40.6
TB1-5	MS25036-149	S4-1	13216E6191-1	20	28	71.1
TB1-6	MS25036-149	K1-1		20	10	25.8
TB2-4	13216E6191-2	K2-C2	MS25036-108	16	36	91.5
TB2-5	13216E6191-2	K2-B2	MS25036-108	16	36	91.5
TB2-6	13216E6191-2	K2-A2	MS25036-108	16	36	91.5
K1-2		K3-X1	MS25036-149	20	13	33.0

TERMINATION		TERMINATION		AGW WIRE	LENGTH	
FROM	TERMINAL TYPE	TO	TERMINAL TYPE	SIZE	IN.	CM
TB1-6	MS25036-149	K4-9		20	16	40.6
K2-C1	MS25036-108	K4-8		16	14	35.6
K2-B1	MS25036-108	K4-11		16	15	38.1
K2-A1	MS25036-108	K4-3		16	14	35.6
K2-X2	MS25036-149	K3-X2		20	14	35.6
K2-X2	MS25036-149	K4-2		20	14	35.6
K5-1		CB2-2	MS25036-101	20	20	50.8
TB1-1	MS25036-156	TB3-1	MS25036-156	12	36	91.5
TB1-4		CR1-4		20	36	91.5
S4-2		S5-1		20	8	20.3
TB2-7		S6-2		16	18	45.7
TB2-8		S6-1		16	18	45.7
TB2-9		S6-3		16	18	45.7
S6-2		S6-4		16	3	7.6

END OF WORK PACKAGE

UNIT MAINTENANCE
AIR CONDITIONER, HORIZONTAL, COMPACT
(NSN 4120-01-502-1319)
CONTROL MODULE ASSEMBLY REMOVAL, REPAIR, AND INSTALLATION

INITIAL SETUP:**Tools**

Refrigeration Unit Service Tool Kit (WP 0092 00, Item 1)

Equipment Condition

Remove return air louver (WP 0018 00)

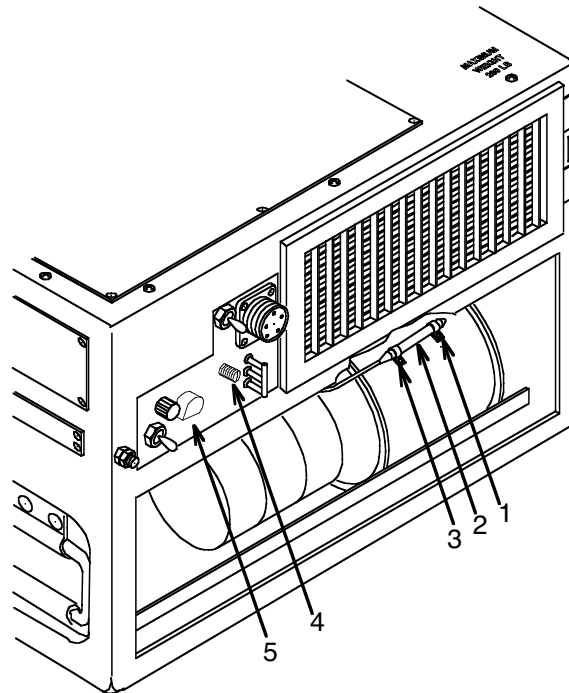
**REMOVAL**

1. Loosen sensing bulb loop clamp screws (1) and slip sensing bulb (2) out of loop clamps (3).
2. Disconnect motor connector P3.
3. Loosen control module mounting screw (4) and carefully pull control module (5) out of unit. Be sure to avoid damage to the sensing line.
4. Carefully work sensing bulb (2) through the frame and out of the unit.

REPAIR

1. See WP 0025 00 for testing of individual components and repair of wire connections.

INSTALLATION

1. Carefully work sensing bulb (2) through junction box frame and into two mounting loop clamps (3) behind return air louver.
2. Tighten the loop clamp screws (1).
3. Reconnect motor connector P3.

4. Slip the control module (5) into the opening in junction box. Take care not to crush or kink sensing bulb capillary line.
5. Tighten control module mounting screw (4).

NOTE

FOLLOW-ON MAINTENANCE
Install return air louver (WP 0018 00)

END OF WORK PACKAGE

UNIT MAINTENANCE
AIR CONDITIONER, HORIZONTAL, COMPACT
(NSN 4120-01-502-1319)

TEMPERATURE SELECTOR SWITCH S3 REMOVAL, INSPECTION, TESTING, AND INSTALLATION

INITIAL SETUP:

Tools

Refrigeration Unit Service Tool Kit (WP 0092 00, Item 1)

Materials/Parts

Temperature Selector
 Self-Locking Nuts (4)
 Self-Locking Screws (3)

Equipment Condition

Remove the control module (WP 0026 00)

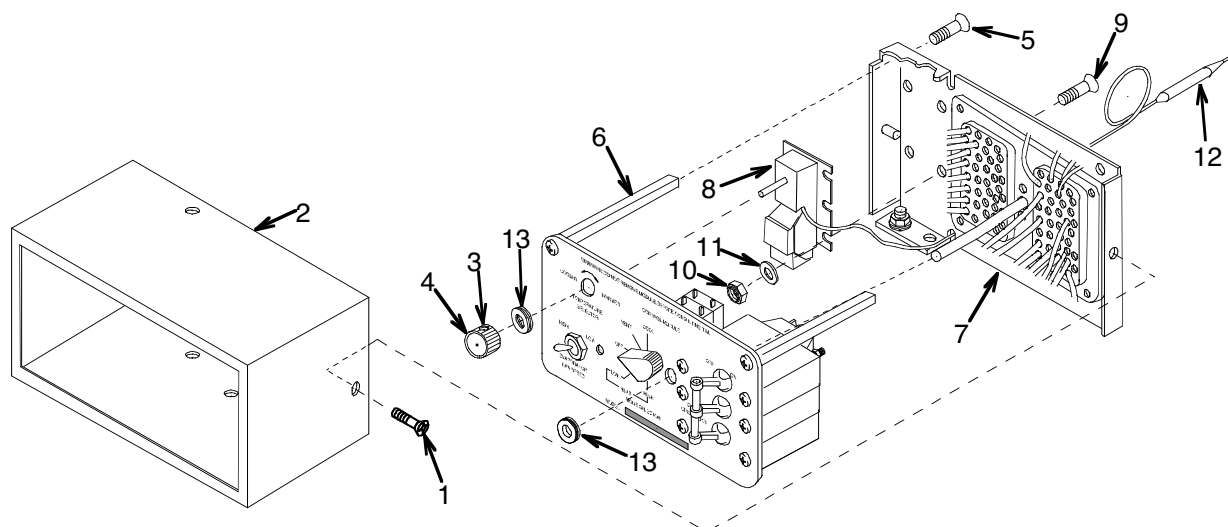

REMOVAL

1. Remove four machine screws (1) and pull control cover (2) off.
2. Loosen setscrew (3) in the knob (4). Remove knob.
3. Cut off all tie wraps.
4. Remove three machine screws (5) from spacer posts (6) and separate the mounting frame (7) from the front of the control panel.
5. Tag and disconnect wires from the thermostatic switch (8) from the mounting frame (7).

INSPECTION

Check the thermostatic switch (8) for kinked or damaged capillary line or bulb and loose, broken, or missing terminals.

TESTING

1. Place the sensing bulb (12) in a container of warm water, 75-85 degrees F (25-30 degrees C) and set multimeter to measure resistance on lowest scale. Place multimeter leads on terminals 1 and 3 of the thermostat (blue and red). Turn the knob to the extreme cooler position. There should be no indication of continuity on multimeter. Turn the knob to the extreme warmer position. Continuity should be indicated on the multimeter. Replace if defective.
2. Center or mid-range of the thermostatic switch represents a setting of about 75 Degrees F (24 Degree C). With the sensing bulb remaining in the container of warm water, 75 – 85 Degrees F (24 – 30 Degrees C), slowly turn the knob from extreme warmer position towards the cooler position. Continuity should cease before or near mid-range of the knob.

INSTALLATION

1. Connect the wire leads and remove tags. (See WP 0028 00)
2. Place the thermostatic switch (8) on the mounting frame (7) and secure with four machine screws (9), flat washers (11), and self-locking nuts (10).
3. Check that grommets (13) are in place in the shaft holes.
4. Slip the mounting frame (7) in place and align holes in the back plate with three spacer posts (6). Check that the grommets (13) are still in place in the shaft holes. Secure with three machine screws (5).
5. Install the knob (4) and tighten the setscrew (3).
6. Secure wires with wire ties as necessary.
7. Slip the control cover (2) in place and secure with four machine screws (1). Be sure the split grommet is in place on the cover (2).

NOTE

FOLLOW-ON MAINTENANCE:
Install control module (WP 0026 00)

END OF WORK PACKAGE

UNIT MAINTENANCE
AIR CONDITIONER, HORIZONTAL, COMPACT
(NSN 4120-01-502-1319)

EVAPORATOR FAN SPEED TOGGLE SWITCH (S2) REMOVAL, INSPECTION, TESTING, AND INSTALLATION

INITIAL SETUP:

Tools

Refrigeration Unit Service Tool Kit (WP 0092 00, Item 1)

Equipment Condition

Remove control module (WP 0026 00)

Materials/Parts

Evaporator Fan Speed Toggle Switch
 Self-Locking Screws (3)

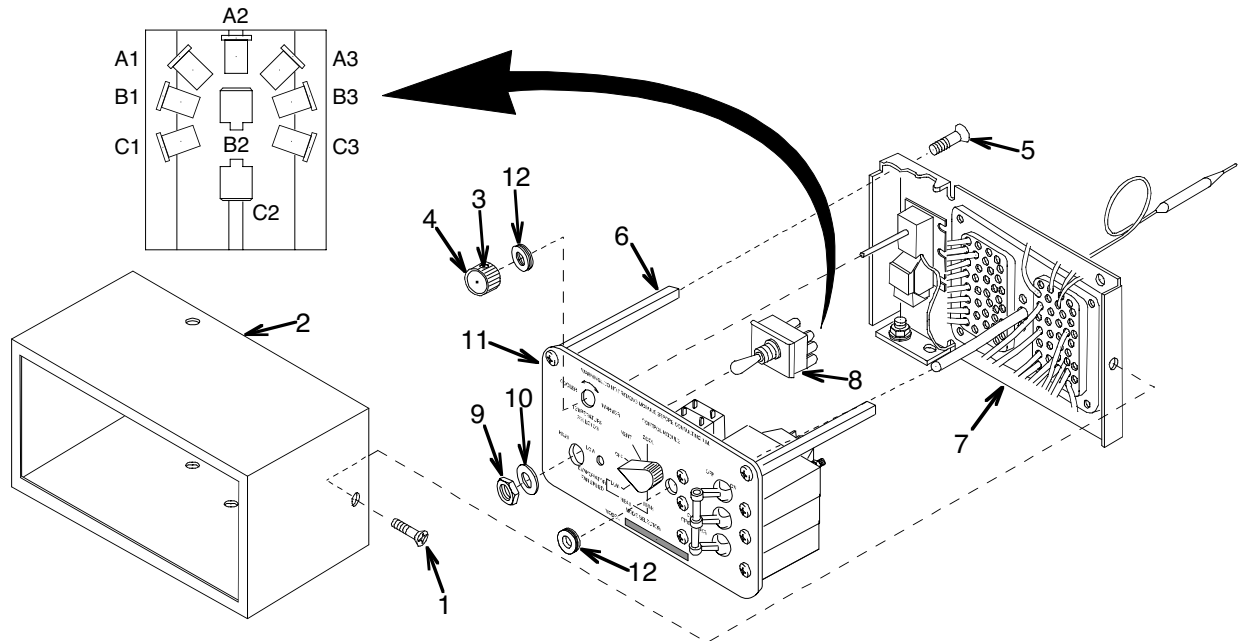

REMOVAL

1. Remove four machine screws (1) and the pull control cover (2).
2. Loosen the setscrew (3) in the knob (4). Remove knob.
3. Cut off all tie wraps.
4. Remove three machine screws (5) from the spacer posts (6) and slip the mounting frame (7) off.
5. Tag and disconnect wires from the Evaporator Fan Speed Toggle Switch (8).
6. Remove the nut (9) and washer (10) and pull the Evaporator Fan Speed Toggle Switch (8) from the designation plate (11).

INSPECTION

Check the Evaporator Fan Speed Toggle Switch for general condition and loose, broken, or missing terminals.

NOTE

Terminals C1 to C2 and C2 to C3 are not used in single-phase units

TESTING

1. With the Evaporator Fan Speed Toggle Switch in high position (toward keyway), check continuity between terminals A1 to A2, B1 to B2, and C1 to C2. Continuity should be indicated across each pair of terminals.
2. With the Evaporator Fan Speed Toggle Switch in low position (away from keyway) check continuity between terminals A2 to A3, B2 to B3, and C2 to C3.

REPLACEMENT

Replace the Evaporator Fan Speed Toggle Switch if defective.

INSTALLATION

1. Insert Evaporator Fan Speed Toggle Switch (8) into control panel designation plate (11) and secure with nut (9) and washer (10).
2. Connect the wire leads and remove tags.
3. Check that the grommets (12) are in place in the shaft holes.
4. Slip the mounting frame (7) in place and align with the three-spacer posts (6). Check that the grommets (12) are still in place in the shaft holes. Secure it with three machine screws (1).
5. Secure wires with tie wraps as necessary.

NOTE

FOLLOW-ON MAINTENANCE:
Install control module (WP 0026 00)

END OF WORK PACKAGE

UNIT MAINTENANCE
AIR CONDITIONER, HORIZONTAL, COMPACT
(NSN 4120-01-502-1319)

MODE SELECTOR SWITCH S1 REMOVAL, INSPECTION, TESTING, AND INSTALLATION

INITIAL SETUP:

Tools

Refrigeration Unit Service Tool Kit (WP 0092 00, Item 1)

Equipment Condition

Remove control module (WP 0026 00)

Materials/Parts

Mode Selector Switch
 Self-locking Screws (3)

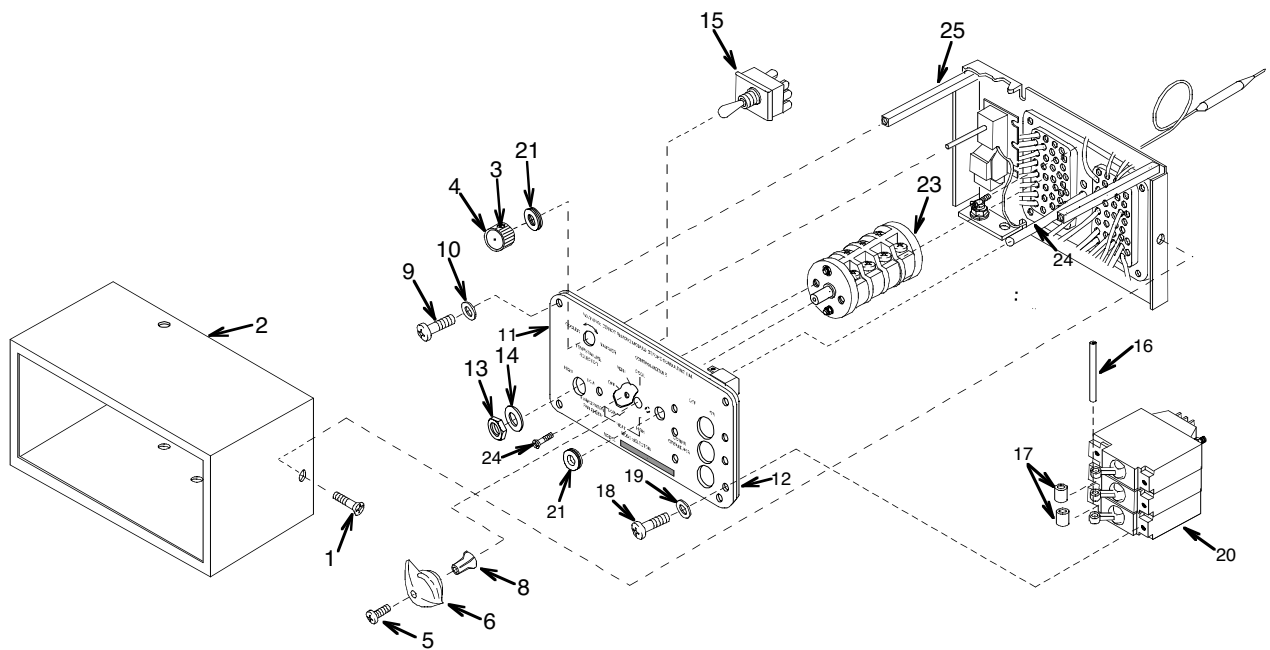

REMOVAL

1. Remove four machine screws (1) and pull off the control cover (2).
2. Loosen setscrew (3) in the knob (4). Remove knob.
3. Cut off all wire tie wraps.
4. Loosen the screw (5) in the top of the knob (6) and remove the knob from the mode selector switch (7). The knob (6) engages the square shaft of the mode selector switch (7) via an adapter (8).
5. Remove the three machine screws (9) and washers (10) from the spacer posts (25) and pull the designation plate (11) and mounting plate (12) away from the rest of the module.

6. Remove the nut (13) and washer (14) and pull the evaporator fan speed toggle switch (15) from the designation plate (11).
7. Remove pin (16) and spacers (17) from the circuit breaker toggles.
8. Remove screws (18) and flat washers (19) and pull the circuit breaker (20) from the designation plate (11).
9. Remove two grommets (21) from the shaft holes in the designation plate (11). The designation plate (11) should fall away from the mounting plate (12).
10. Remove two machine screws (24) from the mode selector switch (23).
11. Tag and disconnect wires from the mode selector switch (23).

INSPECTION

Check switch for overall general condition and loose, broken, or missing terminals.

TESTING

See the mode position chart below and check continuity at pins indicated. Replace the switch if continuities are not in accordance with those indicated.

Table 1. Mode Position Chart.

Switch Position	Function	Switch Deck and Terminals Connected			
		1	2	3	4
1	COOL	3 and 4	7 and 8	11 and 12	15 and 16
2	VENT		7 and 8	11 and 12	15 and 16
3	OFF				
4	(LOW) HEAT	1 and 2	7 and 8	11 and 12	15 and 16
5	(HIGH) HEAT	1 and 2	5 and 6 7 and 8	9 and 10 11 and 12	13 and 14 15 and 16

INSTALLATION

1. Assemble the machine screws (24) and mode selector switch (23) onto the mounting plate (12). Tighten the two machine screws (24) so that the mode selector switch is held firmly in place.
2. Reconnect the wires to the mode selector switch (23) terminals. Remove tags.
3. Place the designation plate (11) over the mounting plate (12) and hold in place.
4. Insert circuit breaker toggles through the designation plate (11). Be sure the OFF position matches the lettering on the designation plate (11).
5. Secure the circuit breaker (20) to the designation plate (11) with screws (18) and flat washers (19).
6. Replace grommets (21) in the shaft holes. Check that they are secure.
7. Insert the evaporator fan speed toggle switch (15) into the designation plate (11). Tighten the nut (13) and washer (14) to secure the designation plate (11) to the spacer posts (25).
8. Insert three machine screws (9) and washers (10) into the spacer posts (25) through the designation plate (11). Tighten the screws to secure the designation plate (11) to the spacer posts (25).
9. Install the knob (4) and tighten the setscrew (3).
10. Insert the pin (16) and spacers (17) in the circuit breaker toggles.

-
11. Place the knob (6) on the mode selector switch (7). Make sure the adapter (8) is positioned on top of the square shaft of the mode selector switch (7).
 12. With the knob (6) and the adapter (8) engaged with the shaft, turn the switch in a clockwise direction.
 13. When the last clockwise position is located, remove the knob (6) leaving the adapter (8) on the shaft. Reposition the knob (6) on the adapter with the pointer pointing in the COOL mode.
 14. Tighten the screw (5) in the top of the knob (6). When the knob (6) is secure, turn it to point in the OFF mode.
 15. Slip the control cover (2) in place and secure it with four machine screws (1).
 16. Secure wires with ties as necessary.

NOTE

FOLLOW-ON MAINTENANCE:
Install control module (WP 0026 00)

END OF WORK PACKAGE

UNIT MAINTENANCE
AIR CONDITIONER, HORIZONTAL, COMPACT
(NSN 4120-01-502-1319)

COMPRESSOR CIRCUIT BREAKER (CB1) REMOVAL, INSPECTION, TESTING, AND INSTALLATION

INITIAL SETUP:

Tools

Refrigeration Unit Service Tool Kit (WP 0092 00, Item 1)

Equipment Condition

Remove the Control Module (WP 0026 00)

Materials/Parts

Compressor Circuit Breaker
 Self-Locking Screws (3)

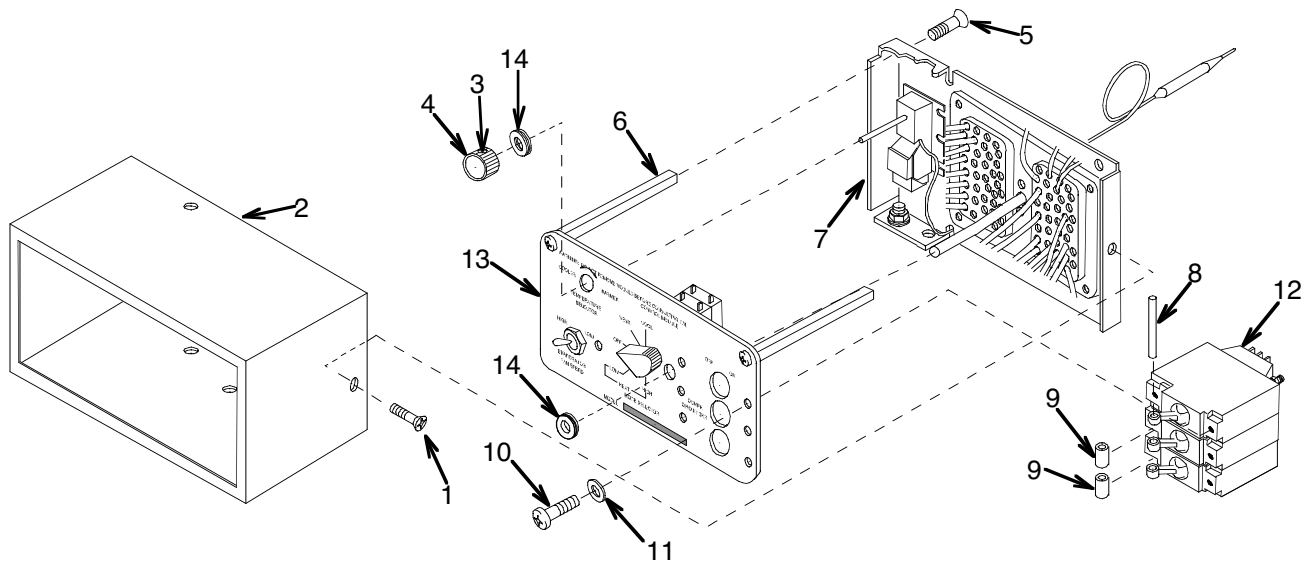

REMOVAL

1. Remove four machine screws (1) and pull off the control cover (2).
2. Loosen setscrew (3) in the knob (4) and remove knob.
3. Cut off all wire tie wraps.
4. Remove three self-locking machine screws (5) from the spacer posts (6) and remove the back mounting plate (7).
5. Tag and disconnect the wires from the Compressor Circuit Breaker (12).
6. Remove pin (8) and spacers (9) from circuit breaker toggles.
7. Remove screws (10) and flat washers (11) and pull the circuit breaker (12) from the designation plate (13).

INSPECTION

Check the general condition of the circuit breaker and check for loose, broken, or missing terminals.

TESTING

1. Ensure that continuity exists on each pair of terminals when circuit breaker is in the on position.
2. Ensure that there is no continuity between terminals with the circuit breaker in the off position.

-
3. If continuity exists, replace circuit breaker.

INSTALLATION

1. Insert circuit breaker toggles through the control panel. Be sure the OFF position matches lettering on the panel.
2. Secure circuit breaker (12) to panel with screws (10) and flat washers (11).
3. Insert pin (8) and spacers (9) through circuit breaker toggles and lock them together.
4. See tags and wiring diagram (WP 0013 00) and connect the wire leads. Remove tags.
5. Check that the grommets (14) are secure in the shaft holes.
6. Slip the back mounting plate (7) in place and align holes with three spacer posts (6). Check that the grommets (14) are still in place in the shaft holes. Secure with three self-locking screws (5).
7. Secure wires with ties as necessary.
8. Install the knob (4) and tighten the setscrew (3).
9. Slip the control cover (2) in place and secure with four machine screws (1).

NOTE

FOLLOW-ON MAINTENANCE:
Install control module (WP 0026 00)

END OF WORK PACKAGE

UNIT MAINTENANCE
AIR CONDITIONER, HORIZONTAL, COMPACT
(NSN 4120-01-502-1319)

CONTROL MODULE ROTARY SWITCH RELAY INSPECTION, REMOVAL, TESTING, REPAIR, AND INSTALLATION

INITIAL SETUP:

Tools

Refrigeration Unit Service Tool Kit (WP 0092 00, Item 1)

Materials/Parts

Relay, Rotary Switch

Equipment Condition

Remove control module (WP 0026 00)

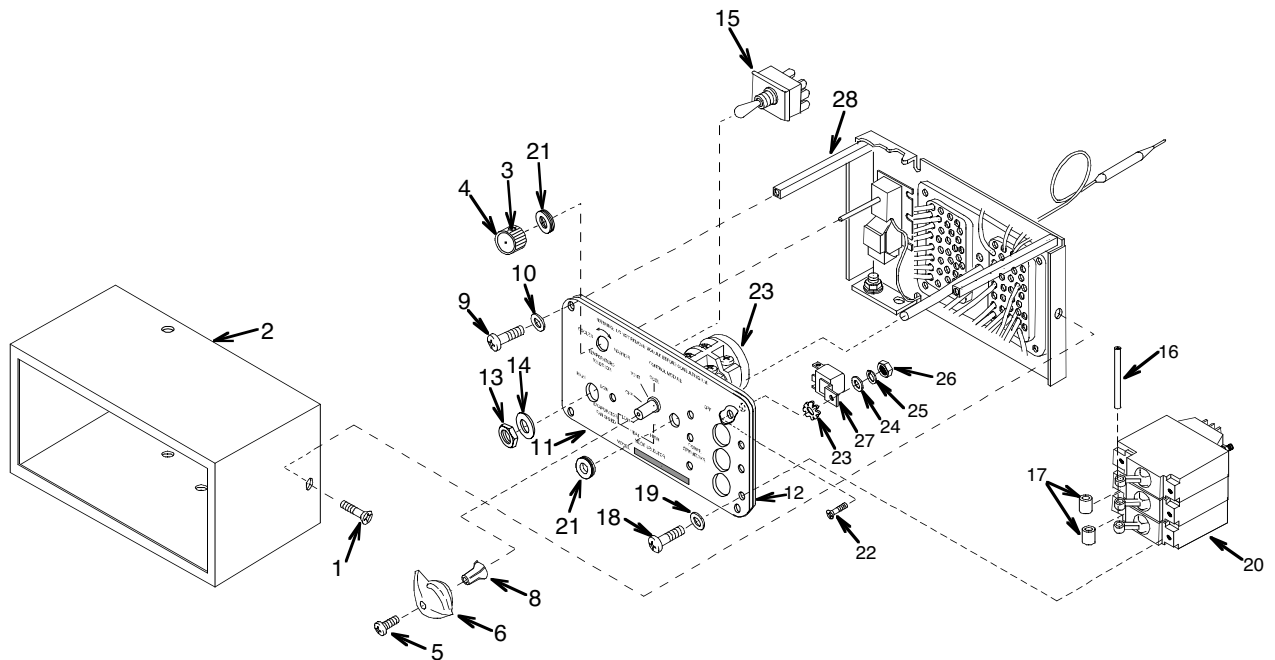

INSPECTION

1. Remove four machine screws (1) and pull off the control cover (2).
2. Inspect the connections at the rotary switch relay (27) for loose, damaged, or missing connectors or terminals. Replace if defective.

REMOVAL

1. Remove the four machine screws (1) and pull off the control cover (2).
2. Loosen the set screw (3) in the knob (4) and remove the knob from the temperature control switch.
3. Cut off all wire tie straps.
4. Loosen the screw (5) in the top of the knob (6) and remove the knob from the mode selector switch (7). The knob (6) engages the square shaft of the mode selector switch (7) via an adaptor (8).
5. Remove three machine screws (9) and washers (10) from the spacer posts (28) and pull the designation plate (11) and mounting plate (12) away from the rest of the module.
6. Remove the nut (13) and washer (14) and pull the evaporator fan speed toggle switch (15) from the designation plate.
7. Remove pin (16) and spacers (17) from the circuit breaker toggles.
8. Remove screws (18) and flat washers (19) and pull the circuit breaker (20) from the designation plate (11).
9. Remove the two grommets (21) from the shaft holes in the designation plates (11). The designation plate (11) should fall away from the mounting plate (12).
10. Remove machine screw (22), washer (23), lock-spring washer (24), lock washer (25), and nut (26) from the rotary switch relay (27).
11. Tag and disconnect wires from the rotary switch relay (27).

TESTING

Check continuity across the relay terminals. The electrical paths across 85 to 86, and 30 to 87A, should be closed. All other paths should be open. Replace the relay if defective.

INSTALLATION

1. Reconnect the wires to the relay terminals. Remove tags.
2. Assemble the machine screw (22), washer (23), lock-spring washer (24), lock-washer (25), and nut (26) to attach the rotary switch relay (27) to the mounting plate (12). Tighten the screw/nut assembly so the rotary switch relay (27) is held firmly in place.
3. Place the designation plate (11) over the mounting plate (12) and hold in place.
4. Install grommets (21) in the shaft holes. Check that they are secure.
5. Insert circuit breaker toggles through the designation plate (11). Be sure the OFF position matches the lettering on the designation plate (11).
6. Secure the circuit breaker (20) to the designation plate (11) with screws (18) and flat washers (19).
7. Insert the evaporator fan speed toggle switch (15) into the designation plate (11), tighten the nut (13) and washer (14) to secure the designation plate (11) to the spacer posts (28).
8. Check that grommets (13) are in place in the shaft holes.
9. Slip the mounting frame (7) in place and align holes in the back of the plate with three spacer posts (6). Check that grommets (13) are still in place in the shaft holes. Secure with three machine screws (5).
10. Insert the three machine screws (9) and washers (10) into the spacer posts (28) through the designation plate (11). Tighten the screws to secure the designation plate (11) to the spacer posts.
11. Install the knob (4) and tighten the setscrew (3).
12. Insert the pin (16) and spacers (17) in the circuit breaker toggles.

-
13. Place the knob (6) on the mode selector switch (7). Make sure the adapter (8) is positioned on top of the square shaft of the mode selector switch (7).
 14. With the knob (6) and the adapter (8) engaged with the shaft, turn the switch in a clockwise direction.
 15. When the last clockwise position is located, remove the knob (6) leaving the adapter (8) on the shaft. Reposition the knob (6) on the adapter with the pointer pointing in the COOL mode.
 16. Tighten the screw (5) in the top of the knob (6). When the knob (6) is secure, turn it to point in the OFF mode.
 17. Secure all wire with tie straps as necessary.
 18. Slip the control cover (2) in place and secure it with four machine screws (1).

NOTE

FOLLOW-ON MAINTENANCE:
Install control module (WP 0026 00)

END OF WORK PACKAGE

UNIT MAINTENANCE
AIR CONDITIONER, HORIZONTAL, COMPACT
(NSN 4120-01-502-1319)

CONTROL MODULE WIRING HARNESS INSPECTION, REMOVAL, TESTING, REPAIR, AND INSTALLATION

INITIAL SETUP:

Tools

Refrigeration Unit Service Tool Kit (WP 0092 00, Item 1)

Materials/Parts

Control Module Wiring Harness
 Self-Locking screws (3)
 Self-Locking nuts (8)

Equipment Condition

Remove control module (WP 0026 00)

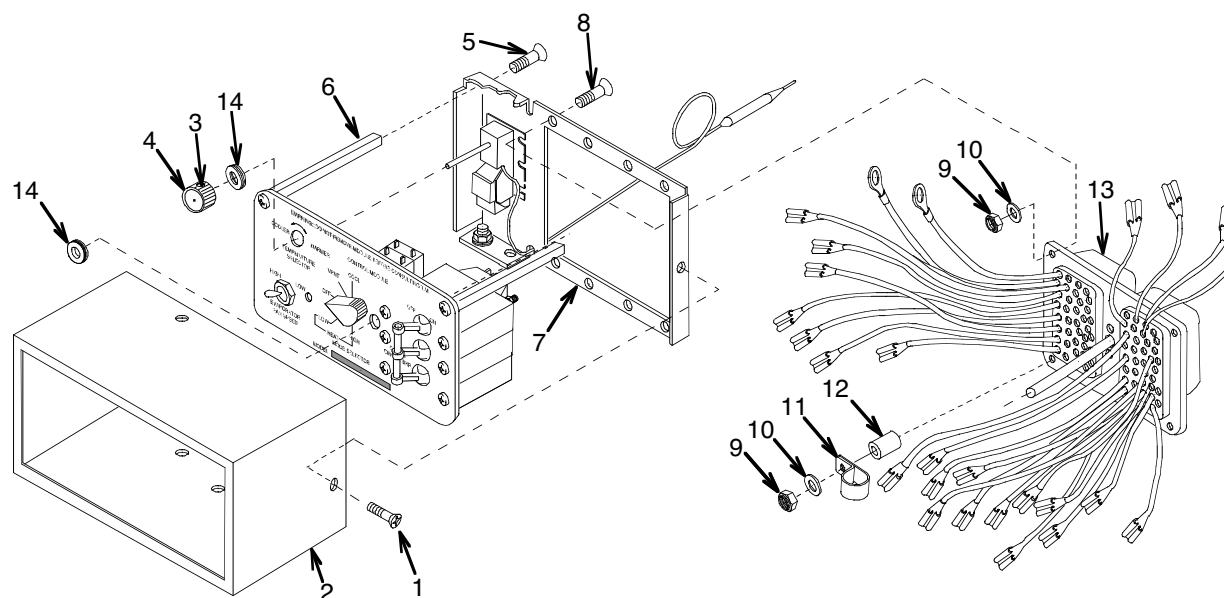

INSPECTION

1. Remove four machine screws (1) and pull off the control cover (2).
2. Inspect the connector receptacle J2 (13) for loose, damaged, or missing pins. Replace if defective.
3. Check individual wires for loose solder connections, loose terminal lugs, cut or frayed insulation, and cut or broken wires.

REMOVAL

1. Loosen the setscrew (3) in the (4). Remove knob.
2. Remove three self-locking screws (5) from the spacer posts (6) and remove the back mounting plate (7).
3. Tag and disconnect the wires from components and the ground stud.
4. Remove seven machine screws (8), self-locking nuts (9), and flat washers (10).
5. Remove screw (8), self-locking nut (9), flat washer (10), loop clamp (11), and electrical post (12). Pull the connector receptacle (13) from the back mounting plate (7).

TESTING

See the wiring diagram (WP 0013 00). Test continuity between individual wires and corresponding pin connectors. Replace or repair wires with no continuity.

REPAIR

1. See WP 0028 00 for general wire repair instructions.
2. See WP 0028 00, Wire List for wire lengths and terminal information when individual wires are replaced.
3. Replace the harness assembly if the connector receptacle (13) is damaged.

INSTALLATION

1. Fit the connector receptacle (13) into the back mounting plate (7) and secure it with seven machine screws (8), nuts (9), and flat washers (10).
2. Install electrical post (12) and loop clamp (11). Secure with machine screw (8), flat washer (10), and self-locking nut (9).
3. See the tags and wiring diagram (WP 0013 00) and connect the wire leads. Remove tags.
4. Ensure that the grommets (14) are in place in the shaft holes.
5. Slip the back mounting plate (7) in place and align the holes in the back plate (7) with three spacer posts (6). Ensure the grommets (14) are in place in the shaft holes. Secure with three self-locking screws (5).
6. Install the knob (4) and tighten the setscrew (3).
7. Slip the control cover (2) in place and secure with four machine screws (1).

NOTE

FOLLOW-ON MAINTENANCE:
Install control module (WP 0026 00)

UNIT MAINTENANCE
AIR CONDITIONER, HORIZONTAL, COMPACT
(NSN 4120-01-502-1319)
JUNCTION BOX REMOVAL, INSPECTION, REPAIR, AND INSTALLATION

INITIAL SETUP:

Tools

Refrigeration Unit Service Tool Kit (WP 0092 00, Item 1)

Equipment Condition

Remove control module (WP 0026 00)
 Remove Top Panel (WP 0016 00)

Materials/Parts

Lock Washers (7)

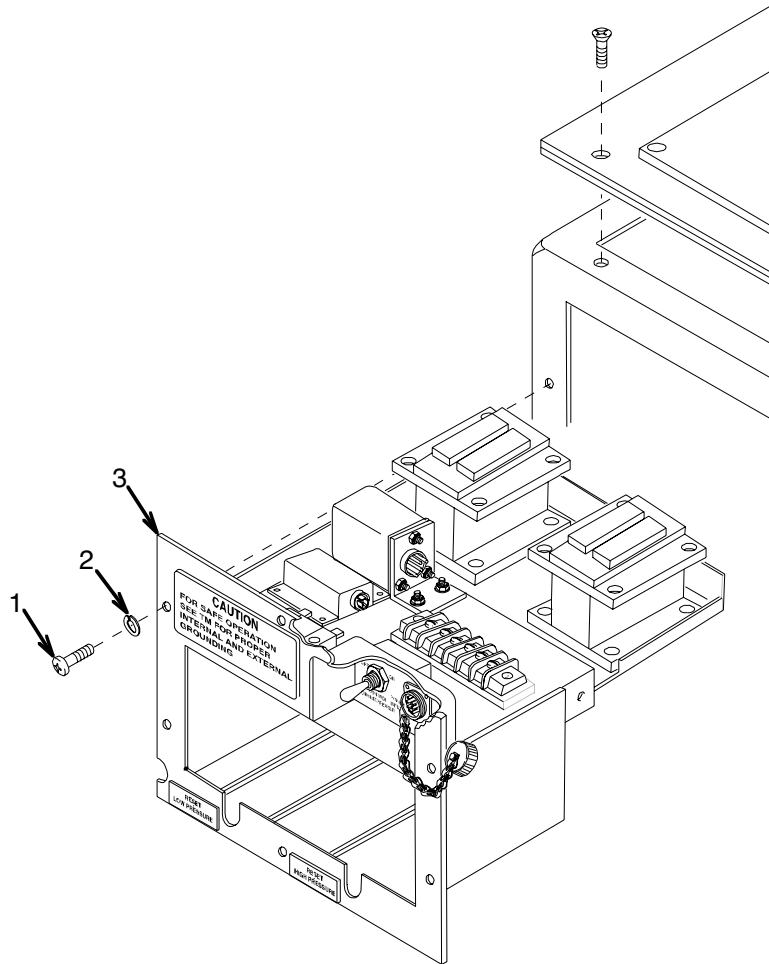

REMOVAL

1. Remove seven screws (1) and lock washers (2) and carefully slide junction box (3) out of unit.

CAUTION

The junction box should be supported on a stand or a table to avoid damage to wires or connections.

NOTE

Most maintenance, testing, and inspection of the junction box and individual components can be done at this stage. Proceed to Step 2 if the entire junction box is to be replaced or removed.

2. Tag and disconnect individual wires and connectors of the junction box harness from the unit.
3. Remove the junction box.

INSPECTION

Inspect for missing or loosely attached hardware, damaged parts, and excessive corrosion. Tighten the loose hardware and clean or repair the parts as indicated.

REPAIR

Replace missing hardware and damaged parts. If junction box is damaged beyond repair, remove the components and replace with a new junction box.

INSTALLATION

1. If the wiring harness was disconnected from the unit, refer to wiring diagram (WP 0013 00). Tag and connect all wire leads and connectors. Remove tags.
2. Carefully slide the junction box (3) into place and secure with seven screws (1) and lock washers (2).

NOTE

FOLLOW-ON MAINTENANCE:
Install control module (WP 0026 00)
Install top front panel (WP 0016 00)

END OF WORK PACKAGE

UNIT MAINTENANCE
AIR CONDITIONER, HORIZONTAL, COMPACT
(NSN 4120-01-502-1319)

JUNCTION BOX WIRING HARNESS INSPECTION, REMOVAL, TESTING, REPAIR, AND INSTALLATION

INITIAL SETUP:

Tools

Refrigeration Unit Service Tool Kit (WP 0092 00, Item 1)

Equipment Condition

Remove Top Panel (WP 0016 00)
 Remove Junction Box (WP 0033 00)

Materials/Parts

Junction Box Wiring Harness
 Gasket

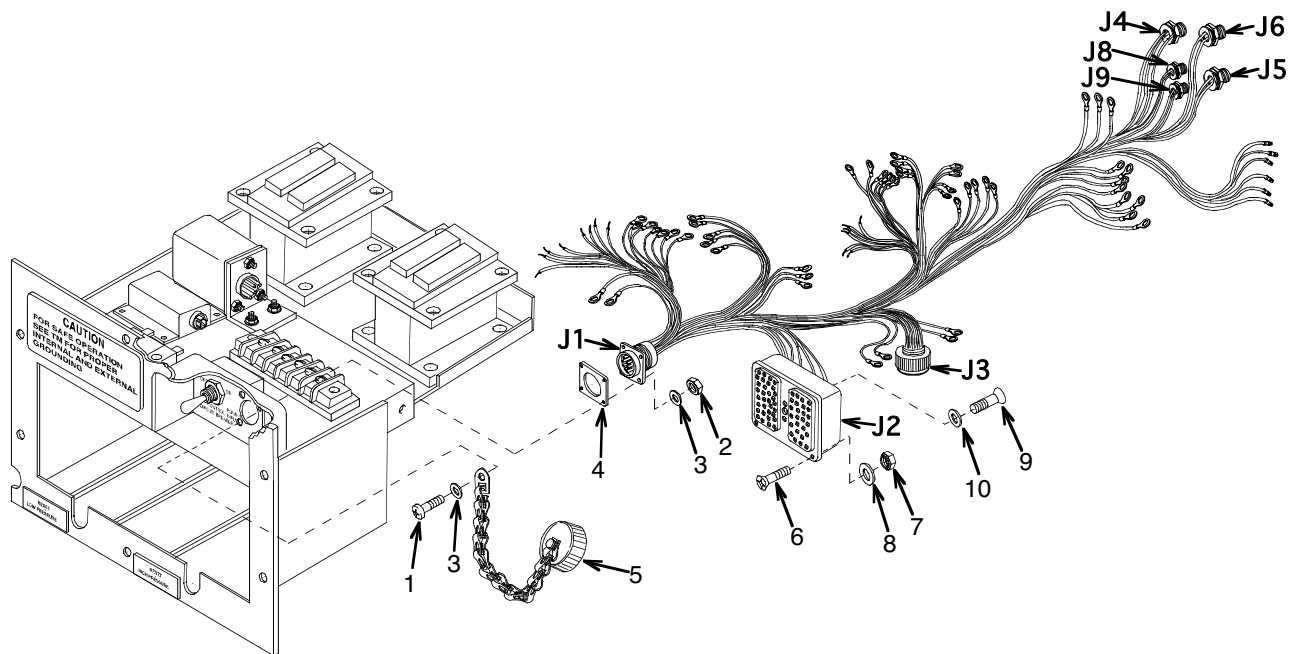

INSPECTION

1. Inspect connectors for loose, damaged, or missing pins. Replace if defective.
2. Check individual wires for loose solder connections, loose terminal lugs, cut or frayed insulation, cut or broken wires.

REMOVAL

1. Tag and disconnect individual wires.
2. Remove nuts and J3 through J6, J8 and J9 connectors from the unit.
3. Remove four screws (1) and nuts (2), eight flat washers (3), gasket (4), and cap and chain (5) from J1 connector.
4. Remove eight screws (6), lock nuts (7), flat washers (8), one screw (9), and a lock washer (10) from the J2 connector.

TESTING

See the wiring diagram (WP 0013 00) and conduct continuity tests on individual wires. Replace or repair wires with no continuity.

REPAIR

1. See WP 0028 00 for general wire repair instructions.
2. See WP 0028 00, Wire List, for wire lengths and terminal information when individual wires are replaced.
3. Replace individual wires, terminals, or connectors if defective.

INSTALLATION

1. Install the J2 connector with one screw (9), lock washer (10), eight screws (6), lock nuts (7), and flat washers (8).
2. Install the J1 connector, gasket (4), and cap and chain (5) with four screws (1), nuts (2), and eight flat washers (3).
3. Install J3 through J6, J8 and J9 connectors. Secure with nuts.
4. Refer to Wiring Diagram (Fig. 4-4) and tag and connect the wire leads and connectors. Remove tags.

NOTE

FOLLOW-ON MAINTENANCE:
Install junction box (WP 0033 00)
Install top panels (WP 0016 00)

END OF WORK PACKAGE

UNIT MAINTENANCE
AIR CONDITIONER, HORIZONTAL, COMPACT
(NSN 4120-01-502-1319)

TIME DELAY RELAY (K1) TESTING, INSPECTION, REMOVAL, AND INSTALLATION

INITIAL SETUP:

Tools

Refrigeration Unit Service Tool Kit (WP 0092 00, Item 1)
 Power Supply (WP 0092 00, Item 3)

Materials/Parts

Time delay relay
 self-locking nuts (2)

Equipment Condition

Remove Junction Box (WP 0033 00)

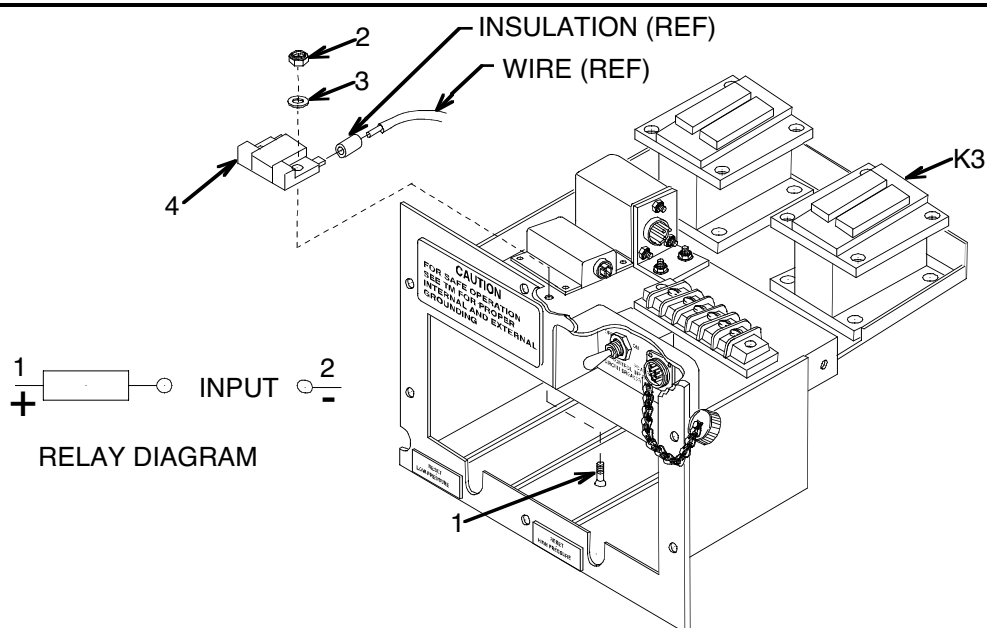

TESTING

1. Connect the multimeter to terminal A1 and A2 of the relay K3.
2. Apply +28VDC to terminal 6 of TB1 and -28VDC to terminal X2 of K3.
3. Multimeter must show continuity across terminals A1 and A2 within 30 +/- 3 seconds after applying the 28 VDC.
4. Remove the 28 VDC. The multimeter must show that the contacts are open. Replace individual relays if defective.

INSPECTION

Check relay for general condition and loose, broken, or missing terminals.

REMOVAL

1. Tag and disconnect all wires to the relay.
2. Remove two screws (1), self-locking nuts (2), and flat washers (3).
3. Pull the relay (4) from the junction box.

INSTALLATION

1. Mount the relay using two screws (1), self-locking nuts (2), and flat washers (3).
2. Refer to the Wiring Diagram and tag and connect wire leads. (WP 0013 00).

NOTE

FOLLOW-ON MAINTENANCE:
Install junction box (WP 0033 00)

END OF WORK PACKAGE

UNIT MAINTENANCE
AIR CONDITIONER, HORIZONTAL, COMPACT
(NSN 4120-01-502-1319)
PHASE SEQUENCE RELAY (K5) TESTING AND REPLACEMENT

INITIAL SETUP:**Tools**

Refrigeration Unit Service Tool Kit (WP 0092 00, Item 1)

Equipment Condition

Remove Return Air Louver (WP 0018 00)
 Remove Junction Box (WP 0033 00)

Materials/Parts

Phase sequence relay
 Self-locking nuts (4)

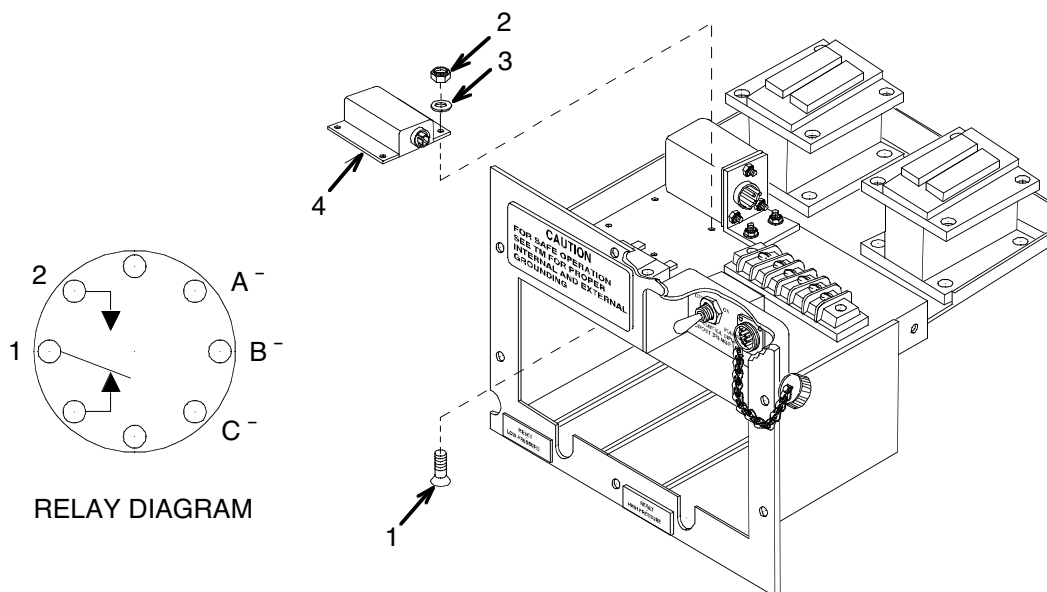
**NOTE**

The relay will energize when all three phases of input power are in proper sequence and when input voltage and frequency are within 10% of that specified (208 volt, 400 hertz).

TESTING

1. Ensure that power connections are properly connected.
2. Move circuit breakers CB1 and CB2 to the ON position.
3. Momentarily turn the mode selector switch to VENT and then back to OFF.
4. To check for correct input phasing, ensure that the blower is rotating counter-clockwise and facing shaft-end. If not, reverse the two input leads at the power source and re-check.
5. To test the phase sequence relay, turn the mode selector switch to the COOL position and check to see if condenser fan is on. If not, replace the phase sequence relay.

REPLACEMENT

1. Remove the Junction Box (WP 0033 00).
2. Tag and disconnect all wires from the relay.
3. Remove relay K4 from the mounting bracket (WP 0038 00).
4. Remove four screws (1), self-locking nuts (2), and flat washers (3) from the phase sequence relay.
5. Pull the relay (4) from the junction box.
6. Mount the relay using four screws (1), self-locking nuts (2), and flat washers (3) to the phase sequence relay.
7. Secure the relay (K4) to the mounting bracket (WP 0038 00).
8. See WP 0013 00, Wiring Diagram. Connect all wires and leads. Remove tags.

NOTE

FOLLOW-ON MAINTENANCE:
Install Junction Box (WP 0033 00)
Install Return Air Louver (WP 0018 00)

END OF WORK PACKAGE

UNIT MAINTENANCE
AIR CONDITIONER, HORIZONTAL, COMPACT
(NSN 4120-01-502-1319)
RELAYS K2 AND K3 INSPECTION, TESTING, AND REPLACEMENT

INITIAL SETUP:

Tools

Refrigeration Unit Service Tool Kit (WP 0092 00, Item 1)
 Power Supply (WP 0092 00, Item 3)

Materials/Parts

Relay

Equipment Condition

Remove Junction Box (WP 0033 00)

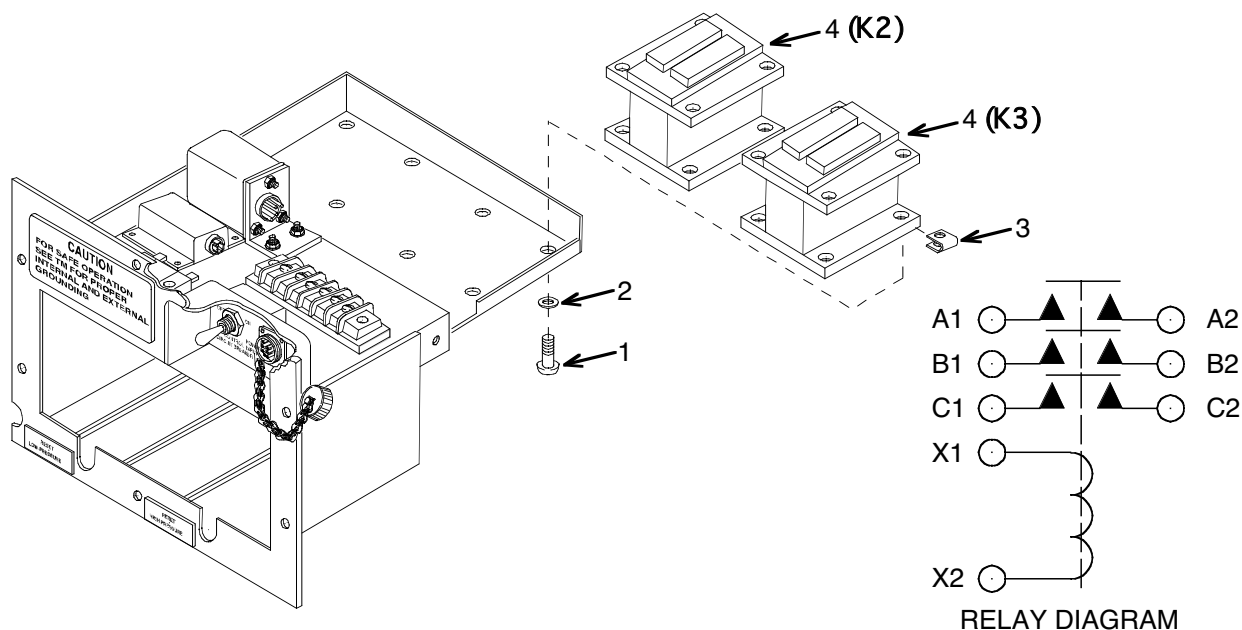

INSPECTION

Check relays for general condition, evidence of overheating, and loose, broken, or missing terminals.

TESTING

1. Apply 28 VDC to terminals X1 (positive) and X2 (negative).
2. Check continuity across terminals A1 and A2, B1 and B2, and C1 and C2. The multimeter must show that contacts are closed.
3. Remove power. The multimeter must show that contacts are open.
4. Replace the relay if defective.

REPLACEMENT

1. Tag and disconnect all wires from the relay.
2. Remove four screws (1), flat washers (2), and clips (3).
3. Pull the relay (4) from the Junction Box.
4. Mount the new relay using four screws (1), flat washers (2), and clips (3).
5. See WP 0013 00, Wiring Diagram. Connect all wire leads.

NOTE

FOLLOW-ON MAINTENANCE:
Install Junction Box (WP 0033 00)

END OF WORK PACKAGE

UNIT MAINTENANCE
AIR CONDITIONER, HORIZONTAL, COMPACT
(NSN 4120-01-502-1319)
RELAY K4 INSPECTION, TESTING, AND REPLACEMENT

INITIAL SETUP:**Tools**

Refrigeration Unit Service Tool Kit (WP 0092 00, Item 1)
 Power Supply (WP 0092 00, Item 3)

Materials/Parts

Relay
 Self-locking nuts (3)

Equipment Condition

Remove Junction Box (WP 0033 00)

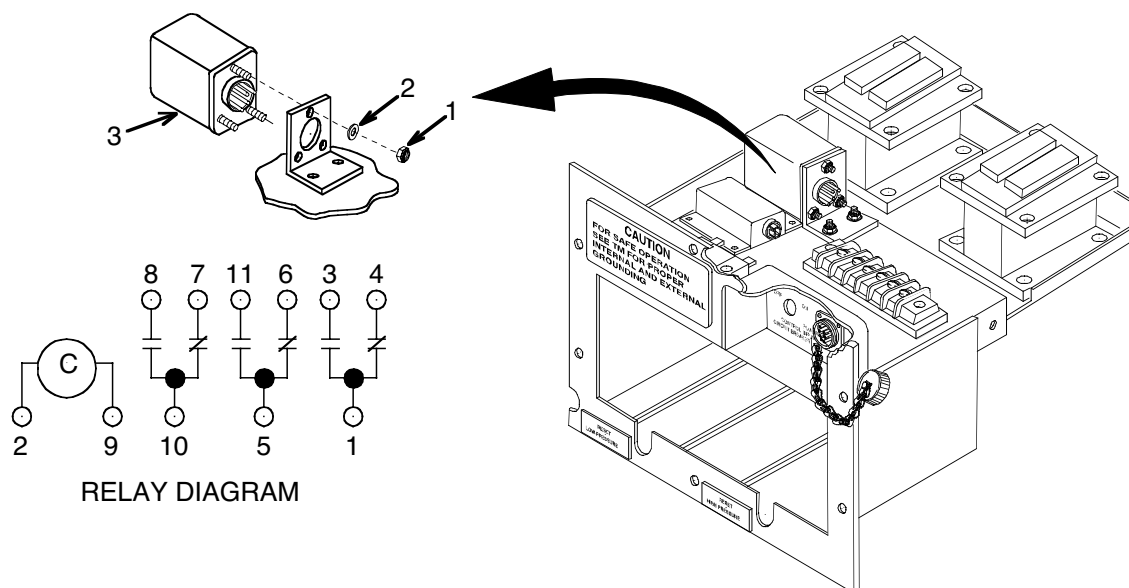
**INSPECTION**

Check the relay for general condition, evidence of overheating, and loose, broken, or missing terminals.

TESTING

1. Apply +28 VDC to terminal TB1-6 and -28 VDC to terminal TB1-4.

NOTE

Terminals 10 and 8 are not used in single-phase units

2. Check continuity across terminals 1 and 3, 5 and 11, and 10 and 8.
3. Check the multimeter. It should indicate that terminals 1 and 3, 5 and 11, and 10 and 8 are closed. Terminals 1 and 4, 5 and 6, and 10 and 7 are open.
4. Remove 28 VDC power. The Multimeter should indicate that terminals 1 and 4, 5 and 6, and 10 and 7 are closed and that terminals 1 and 3, 5 and 11, and 10 and 8 are open.

REPLACEMENT

1. Tag and disconnect all wires from the relay.
2. Remove three self-locking nuts (1) and flat washers (2).
3. Pull the relay (3) from the junction box.
4. Mount the new relay using three self-locking nuts (1) and flat washers (2).
5. See WP 0013 00, Wiring Diagram. Connect all wire leads and remove tags.

NOTE

FOLLOW-ON MAINTENANCE:
Install Junction Box (WP 0033 00)

END OF WORK PACKAGE

UNIT MAINTENANCE
AIR CONDITIONER, HORIZONTAL, COMPACT
(NSN 4120-01-502-1319)
CONTROL CIRCUIT BREAKER CB2 INSPECTION, TESTING, AND REPLACEMENT

INITIAL SETUP:**Tools**

Refrigeration Unit Service Tool Kit (WP 0092 00, Item 1)

Materials/Parts

Control Circuit Breaker
 Lock Washer
 Lock Washers (2)

Equipment Condition

Remove Top Front Panel (WP 0016 00)

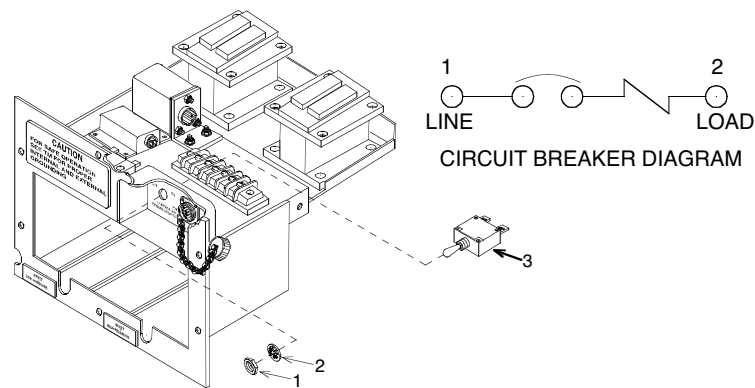
**INSPECTION**

Check the Circuit Breaker for general condition and loose, broken, or missing terminals.

TESTING

1. Check for continuity between the two terminals 1 and 2 with the circuit breaker in the ON position.
2. Check for no continuity between terminals with the circuit breaker in the OFF position.

REPLACEMENT

1. Remove the attaching nut (1) and lock washer (2) from the front panel.
2. Slip circuit breaker (3) from the back of the panel.
3. Tag and disconnect all wire leads.
4. See Wiring Diagram (WP 0013 00). Connect all the wire leads and remove tags.
5. Slip the circuit breaker (3) into the hole in the panel.
6. Secure with a nut (1) and lock washer (2).

NOTE

FOLLOW-ON MAINTENANCE:
 Install Top Front Panel (WP 0016 00)

END OF WORK PACKAGE

UNIT MAINTENANCE
AIR CONDITIONER, HORIZONTAL, COMPACT
 (NSN 4120-01-502-1319)

MISCELLANEOUS CABLES, HARNESSES, AND TERMINAL BOARDS INSPECTION, TESTING, REPAIR, AND REPLACEMENT

INITIAL SETUP:

Tools

Tool Kit, Service, Refrigeration Unit (WP 0092, Item 1)

Equipment Condition

Remove Top Panels (WP 0016 00)
 Remove Junction Box (WP 0033 00)

Materials/Parts

Tie Down Straps

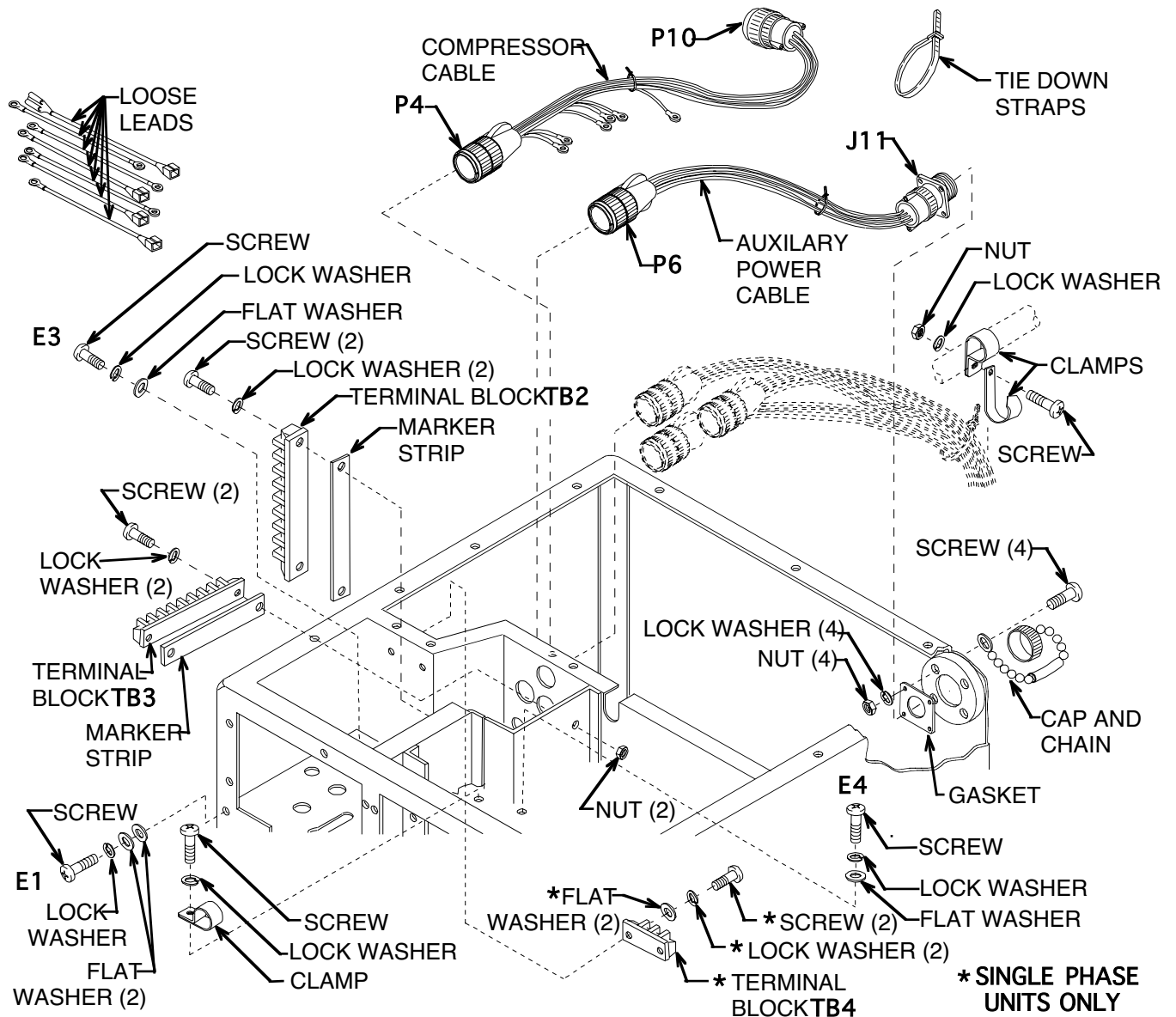

INSPECTION

1. Check all terminals on the terminal board. Ensure they are tight and free of corrosion.
2. Disconnect the connectors and check for loose, damaged, or missing pins.
3. Check individual wires for loose solder connections, cut or frayed insulation, and cut or broken wires.

TESTING

See WP 0013 00, Wiring Diagram. Perform continuity tests on individual wires. Repair or replace wires with no continuity.

REPAIR

1. See WP 0025 00 for general wire repair instructions.
2. See WP 0023 00, Wire List. When replacing individual wires, check for wire lengths and terminal information.

INSTALLATION

Connect all disconnected connectors

NOTE

FOLLOW-ON MAINTENANCE:
Install Junction Box (WP 0033 00)
Install Top Panels (WP 0016 00)

END OF WORK PACKAGE

UNIT MAINTENANCE
AIR CONDITIONER, HORIZONTAL, COMPACT
(NSN 4120-01-502-1319)

RECTIFIER CR1 AND CAPACITORS C1 AND C2 INSPECTION, TESTING, AND REPLACEMENT

INITIAL SETUP:

Tools

Refrigeration Unit Service Tool Kit (WP 0092 00, Item 1)

Materials/Parts

Capacitor

Equipment Condition

Remove Top Front Panel (WP 0016 00)
 Remove Junction Box (WP 0033 00)

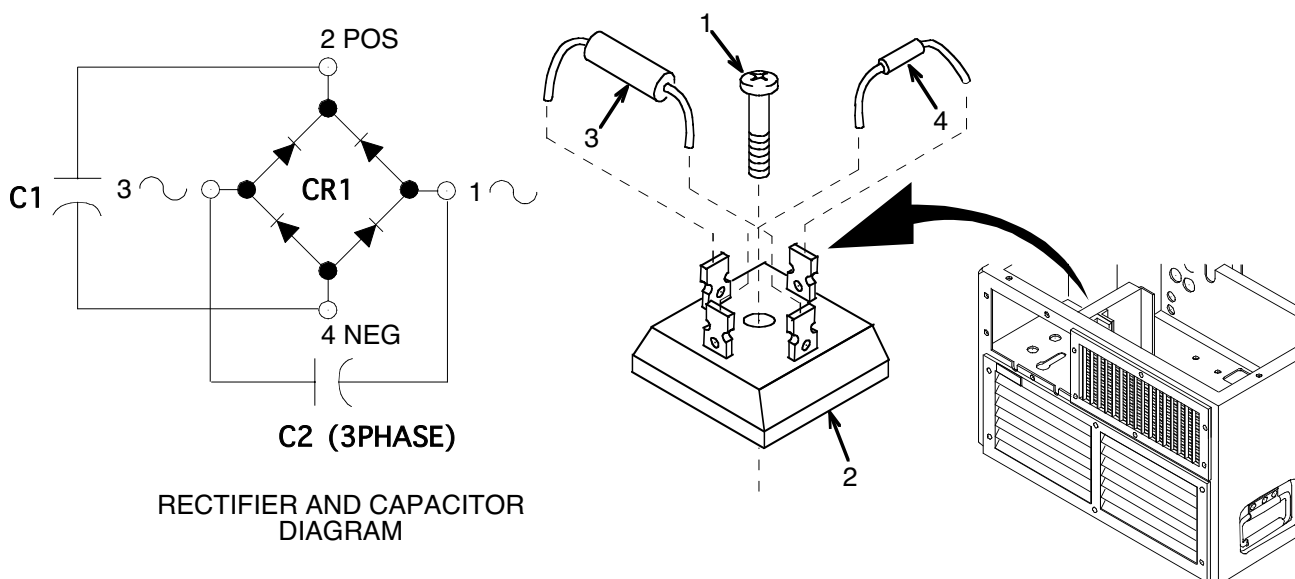

INSPECTION

Check the Rectifier and the Capacitors for general condition and loose, broken, or missing terminals.

TESTING

Rectifier CR1

1. Tag and disconnect ALL wire leads.
2. Using a multimeter on high ohms setting, connect the negative (-) lead to terminal 2 and the positive (+) lead to terminal 1 or 3. A low-resistance reading should be obtained.
3. Connect the positive lead to terminal 2 and the negative lead to terminal 1 or 3. A very high resistance or open circuit reading should be obtained.
4. Connect the positive lead to terminal 4 and the negative lead to terminal 1 or 3. A low resistance reading should be obtained.
5. Connect the negative lead to terminal 4 and the positive lead to terminal 1 or 3. A very high resistance or open circuit reading should be obtained.
6. Replace the defective rectifier and capacitors.
7. See WP 0013 00, Wiring Diagram. Connect ALL wire leads and remove tags.

REPLACEMENT

1. Tag and disconnect ALL wire leads.
2. Remove screw (1) and pull the rectifier (2) from the unit.
3. Cut the terminals from the wire leads and capacitors (C1 and C2 for 3-phase units).
4. Remove the capacitors (3 and 4).

NOTE

When rectifier CR1 is replaced, capacitors (C1 and C2 for 3-phase units) should also be replaced.

5. See WP 0013 00, Wiring Diagram. Using the tags, attach capacitors (3 and 4) and wire leads to their respective terminals.
6. See WP 0013 00, Wiring Diagram. Connect the terminals to the rectifier (2) and remove tags.
7. Install the rectifier (2) and secure with the screw (1).

NOTE

FOLLOW-ON MAINTENANCE:
Install Junction Box (WP 0033 00)
Install Top Front Panel (WP 0016 00)

END OF WORK PACKAGE

UNIT MAINTENANCE
AIR CONDITIONER, HORIZONTAL, COMPACT
(NSN 4120-01-502-1319)
TRANSFORMER T1 INSPECTION AND REPLACEMENT

INITIAL SETUP:**Tools**

Refrigeration Unit Service Tool Kit (WP 0092 00, Item 1)

Materials/Parts

Transformer
 Insulation Tape
 Lock Washers (4)

Equipment Condition

Remove Top Front Panel (WP 0016 00)
 Remove Junction Box (WP 0033 00)

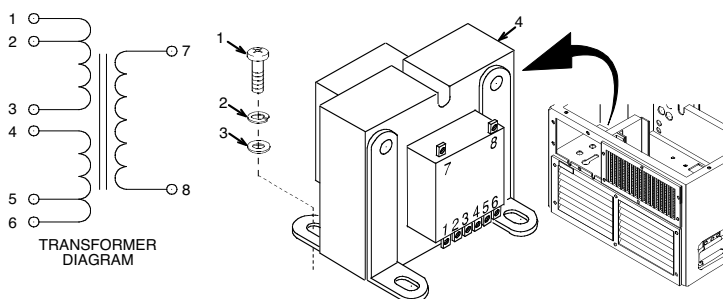
**INSPECTION**

1. Remove four screws (1), lock washers (2), and flat washers (3) and pull the transformer from the unit.
2. Tag and disconnect leads from terminals 2 and 7. Check for continuity across the primary winding pin (pin 2 to pin 5) and across the secondary winding pin (pin 7 to pin 8). If either winding is open, replace the transformer.
3. Check for shorts between terminals of each winding and transformer case and between primary terminals and secondary terminals using a multimeter on high ohms setting. If a short is indicated, replace the transformer.
4. Tag and connect all wire leads and remove tags. (WP 0013 00).
5. Attach the transformer (4) to the unit with four screws (1), lock washers (2), and flat washers (3).

REPLACEMENT

1. Remove four screws (1), lock washers (2), and flat washers (3) and pull the transformer (4) from the unit.
2. Tag and disconnect all wire leads. (WP 0013 00) and replace the transformer.
3. Connect all wire leads to the new transformer and remove tags. (WP 0013 00).
4. Attach the transformer (4) to the unit with four screws (1), lock washers (2), and flat washers (3).

NOTE

FOLLOW-ON MAINTENANCE:
 Install Junction Box (WP 0033 00)
 Install Top Front Panel (WP 0016 00)

END OF WORK PACKAGE

UNIT MAINTENANCE
AIR CONDITIONER, HORIZONTAL, COMPACT
(NSN 4120-01-502-1319)

POWER FACTOR IMPROVEMENT ASSEMBLY TESTING, REMOVAL, AND INSTALLATION

INITIAL SETUP:

Tools

Refrigeration Unit Service Tool Kit (WP 0092 00, Item 1)

Self-locking Nuts (20)
 Lock Washers (18)
 Resilient Mounts (2)
 Insulation Tape (WP 0094 00, Item, 18)
 Rags (WP 0094 00, Item 13)
 Adhesive Remover
 Adhesive (WP 0094 00, Item 2)

Materials/Parts

Evaporator Fan Motor
 Evaporator Fan Impeller
 Evaporator Centrifugal Housing
 Evaporator Fan Inlet Ring

Equipment Condition

Remove Return Air Louver (WP 0018 00)

TESTING

Test fuses. If any fuses are blown, replace the defective fuse (1) and the assembly (2).

REMOVAL

To remove the Power Factor Improvement Assembly:

1. Remove four screws (3), lock washers (4), and flat washers (5).
2. Tag and disconnect wires leads from the power factor improvement assembly (X).
3. Carefully slide the power factor improvement assembly out of the unit.

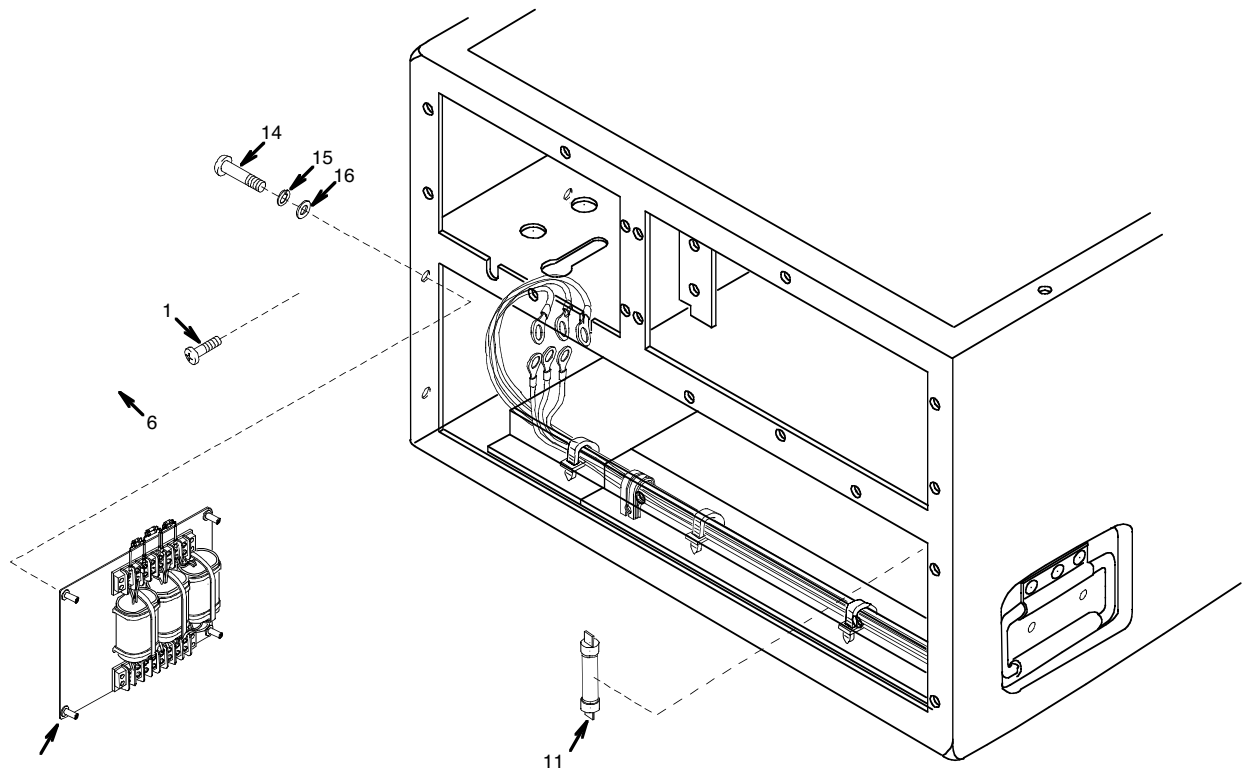

INSTALLATION

1. Carefully slide the power factor assembly (2) into the unit.
2. Connect all wire leads to the power factor assembly and remove tags.
3. Secure the assembly to the unit with four screws (3), lock washers (4), and flat washers (5).

NOTE

FOLLOW-ON MAINTENANCE:
Install Return Air Louver and Air Filter (WP 0018 00)

END OF WORK PACKAGE

UNIT MAINTENANCE
AIR CONDITIONER, HORIZONTAL, COMPACT
(NSN 4120-01-502-1319)

**EVAPORATOR FAN, MOTOR AND HOUSING CLEANING, INSPECTION, TESTING, REMOVAL, ASSEMBLY,
AND INSTALLATION**

INITIAL SETUP:**Tools**

Refrigeration Unit Service Tool Kit (WP 0092 00, Item 1)

Self-locking Nuts (20)
Lock Washers (18)
Resilient Mounts (2)
Insulation Tape (WP 0094 00, Item 18)
Rags (WP 0094 00, Item 13)
Adhesive Remover
Adhesive (WP 0094 00, Item 2)

Materials/Parts

Evaporator Fan Motor
Evaporator Fan Impeller
Evaporator Centrifugal Housing
Evaporator Fan Inlet Ring

Equipment Condition

Remove Return Air Louver (WP 0018 00)

CLEANING

Wipe all dust or dirt from the fan, motor, and housing.

INSPECTION

1. Check that all parts are properly placed and in good condition.
2. Inspect the fan for damaged or bent blades and check the motor for signs of overheating. Check all mounting hardware for tightness.
3. Disconnect the P3 motor connector plug and check for loose, damaged, or missing pins.
4. Inspect the fan's housing for damage and for missing or defective hardware.

TESTING**NOTE**

The motor is capable of operating at two speeds; therefore, there are two sets of field coils.

1. Use an ohmmeter or continuity tester and check the continuity at P3 between pins A and B, A and C, D and E, and E and F. Continuity should exist. If continuity does not exist, allow the motor to cool and retest. If continuity continues to not exist, replace the motor.
2. Check the continuity at P3 from pin G to pins A, B, C, D, E, and F. Continuity should not exist. If continuity does exist, replace the motor.

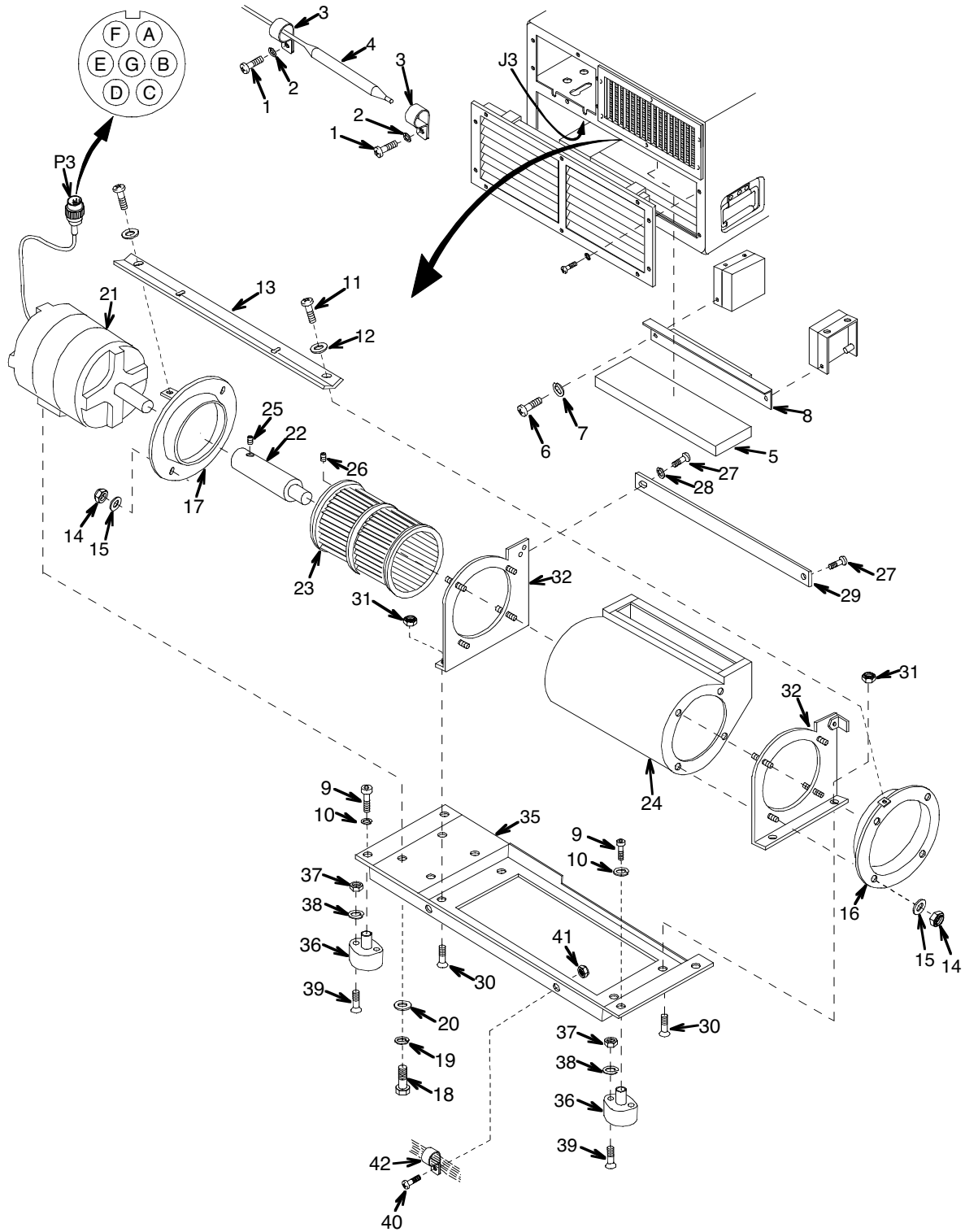

REMOVAL

1. Remove Condensate Drain (WP 0024 00).
2. Disconnect the P3 motor connector plug. Loosen the J3 connector nut to ease removal if necessary.
3. Remove the temperature selector remote sensing bulb (4) from the clamps (3) by loosening the screws (1) and lock washers (2). Remove screws (1), lock washers (2), and clamps (3) from the unit.
4. Remove two screws (40) and lock nuts (41) that secure two clamps (42) to the base (35) to loosen wires.
5. Remove the fan bracket (8) by loosening the two screws (6) and lock washers (7).
6. Remove the four cap screws (9) and lock washers (10). The fan and motor assembly can now be removed from the unit.
7. Replace any defective components found during inspection and testing.

ASSEMBLY

1. If resilient mounts (36) have been removed, attach the new mounts (36) to the unit with two screws (39), flat washers (38), and self-locking nuts (37).
2. Align pins in fan flanges (32 and 33) with holes in the fan housing (34). Attach the fan flanges to the base (35) with four screws (30) and self-locking nuts (31).
3. Attach the fan strap (29) with two screws (27) and flat washers (28).

NOTE

The hub must be turned so that it is mounted toward the motor. The direction of the rotation is clockwise facing the motor shafts.

4. Attach the fan impeller (23) to the shaft (22) and tighten the set screw (26).
5. Slip the shaft extension (22) and the centrifugal housing (17) onto the motor shaft (21) and tighten the set screw (25).
6. Carefully slip the fan impeller (23) and motor assembly (21) into the housing (24).
7. Attach the motor (21) to the base (35) with four cap screws (18), lock washers (19), and self-locking nuts (14).

INSTALLATION

1. Install four cap screws (9) and lock washers (10) onto the fan and motor assembly and place inside the unit.
2. Secure the fan bracket by tightening the two screws (6) and lock washers (7).
3. Install two screws (40) and lock nuts (41), securing two clamps (42) to the base (35) to tighten any loose wires.
4. Install the temperature selector remote sensing bulb (4) to the clamps (3) by tightening screws (1), lock washers (2), and clamps (3) to the unit.
5. Connect the P3 motor connector plug and tighten the J3 connector nut.
6. Install the Condensate Drain (WP 0024 00).

NOTE

FOLLOW-ON MAINTENANCE:
Install Return Air Louver and Air Filter (WP 0018 00)

END OF WORK PACKAGE

UNIT MAINTENANCE
AIR CONDITIONER, HORIZONTAL, COMPACT
(NSN 4120-01-502-1319)
HEATER THERMOSTAT S6 REMOVAL, INSPECTION, TESTING, AND INSTALLATION

INITIAL SETUP:**Tools**

Refrigeration Unit Service Tool Kit (WP 0092 00, Item 1)

Materials/Parts

Heater Thermostat
 Lock Washers (2)

Equipment Condition

Remove Top Front Panel (WP 0016 00)

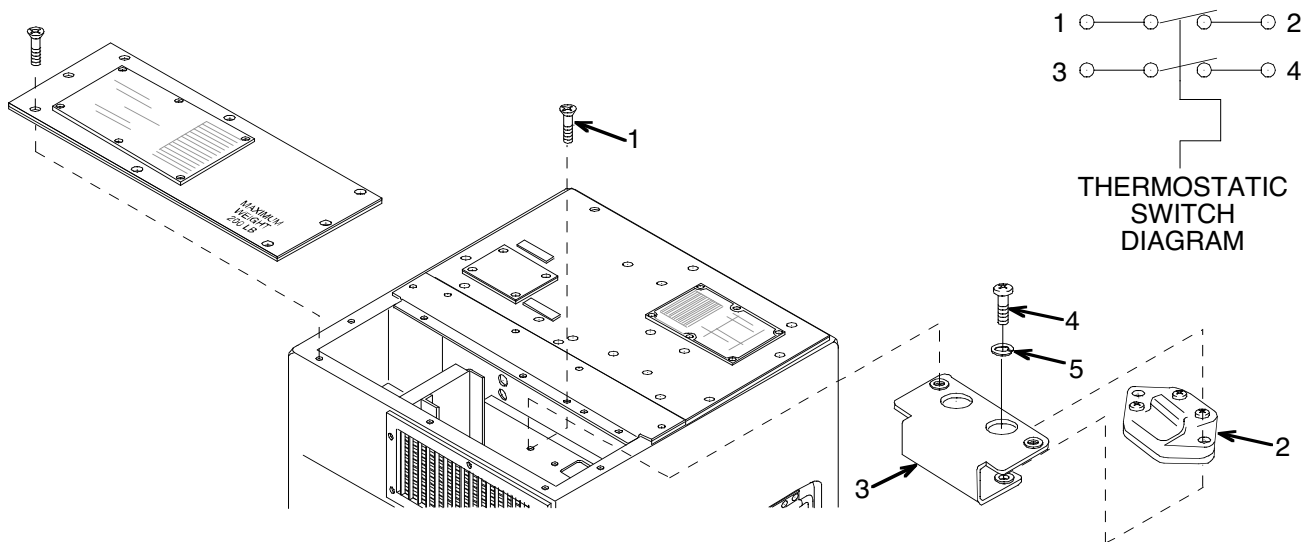
**REMOVAL**

1. Remove two screws (1) and slip the heater thermostat (2) and the bracket (3) forward.
2. Remove two screws (4) and lock washers (5) and pull the thermostat (2) from the bracket (3).
3. Tag and disconnect all wire leads.

INSPECTION

Inspect part for cracks, loose connections, and obvious damage. Replace if defective.

TESTING

1. Check continuity on terminals 1 and 2 of the thermostat. Continuity should be indicated.
2. Check continuity on terminals 3 and 4. Continuity should be indicated.
3. If continuity is not indicated, thermostat is defective and needs to be replaced.

INSTALLATION

1. Connect all wire leads and remove tags (WP 0013 00).
2. Attach the thermostat (2) to the bracket (3) with two screws (4) and lock washers (5).
3. Attach the thermostat (2) and the bracket assembly (3) to the flange of the Top Center Panel with two screws (1).

NOTE

FOLLOW-ON MAINTENANCE:
Install Top Front Panel (WP 0016 00)

END OF WORK PACKAGE

UNIT MAINTENANCE
AIR CONDITIONER, HORIZONTAL, COMPACT
 (NSN 4120-01-502-1319)

HEATER ELEMENTS INSPECTION, TESTING, REMOVAL, CLEANING, REPLACEMENT, AND INSTALLATION

INITIAL SETUP:

Tools

Refrigeration Unit Service Tool Kit (WP 0092 00, Item 1)

Materials/Parts

Heater Element
 Lock Washers (6)
 Rags (WP 0094 00, Item 13)

Equipment Condition

Remove Top Panels (WP 0016 00)
 Remove Junction Box (WP 0033 00)

INSPECTION

Visually inspect each heater for obvious damage, deformation, cracked or broken sheath, burnt out spots, and loose, broken, or otherwise damaged wire leads.

TESTING

1. Use a multimeter to check the resistance of each heating element circuit. A resistance of 35 – 60 ohms should be indicated. See Heater Test Point Table. If any circuit fails resistance check, proceed to step 2.

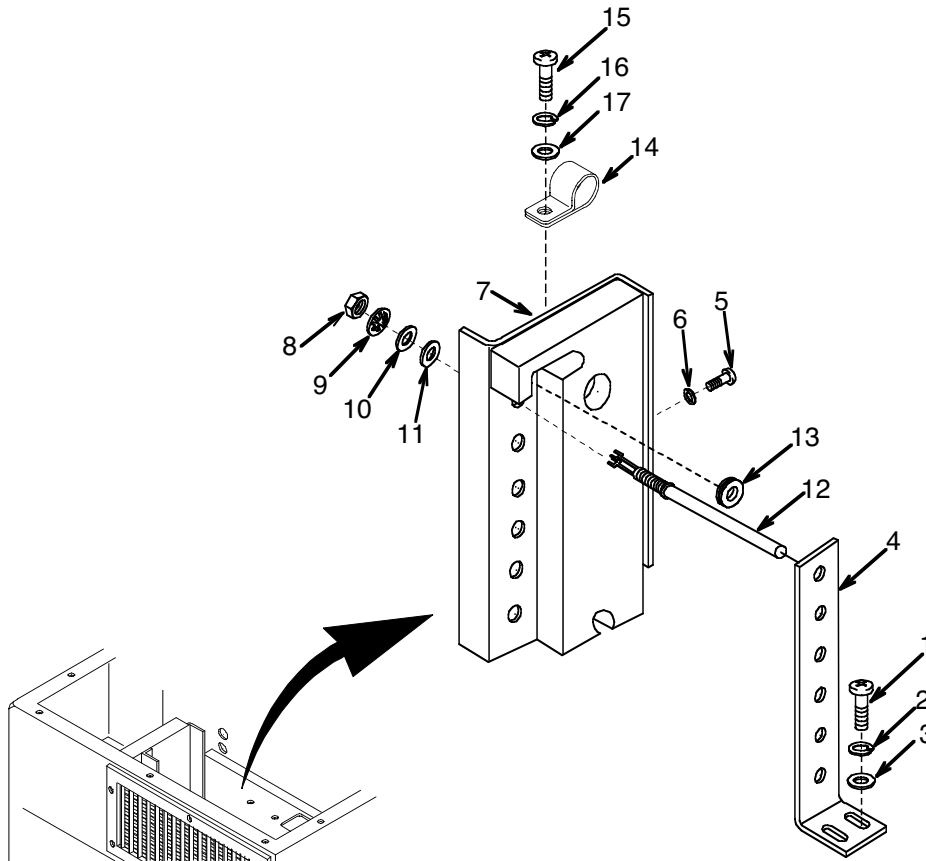

Heater Test Point Table.

HEATER	TEST POINTS		
HR1	S6-2	to	J2A-9
HR2	S6-2	to	K2-C2
HR3	S6-2	to	J2A-8
HR4	S6-2	to	K2-B2
HR5	S6-2	to	J2A-7
HR6	S6-2	to	K2-A2

2. Perform continuity check on the heater cutout switch (S6) between S6 T2 and T1 and between S6 T2 and T3. Continuity should be indicated. If continuity is not indicated, the cutout switch is defective and should be replaced. Repeat step 1 to retest each heating element circuit.
3. Cut all wire tie wraps.
4. Remove two screws and lock washers securing TB3. Lift and remove TB3 from the unit.
5. Remove screw (15), lock washer (16), flat washer (17), and harness clamp (14).
6. Tag and disconnect defective heater element wire leads from TB2. Test each individual heater element resistance to confirm defective heater element. If heater element is confirmed defective, proceed to the procedure for the removal of the heater element located in this work package.

REMOVAL

1. Remove two screws (1), lock washers (2), and flat washers (3) and remove heater support (4).
2. Remove three screws (5) and lock washers (6) from the heater-mounting bracket (7).
3. Slip the bracket up enough to gain access to the top heater.
4. Remove the retaining nut (8), lock washer (10), and insulating washer (11) and slip the heater (12) out of the bracket.
5. Using the same methods (4 and 5) as above, remove any remaining heaters.

CLEANING

Use a clean, dry cloth to wipe dust and dirt from the heaters. Do not use solvents or detergents.

INSTALLATION

1. Position the heater-mounting bracket into the top of the unit so that heaters can be mounted one at a time; start with the bottom most heaters to be installed.
2. Slip the heater through the bracket hole and secure with a nut (8), lock washer (9), flat washer (10), and insulating washer (11) that are provided with the heater (12).
3. Connect the necessary wiring from the heater element to the TB2 per each heating element.
4. Install all remaining heaters and connect all necessary wiring one at a time. Slide the mounting bracket down progressively as each heater is installed.
5. Once all heaters have been installed, be sure that the rubber seal is securely in place.
6. Install three screws (5) and lock washers (6) in the heater-mounting bracket (7).
7. Place the heater support (4) in the unit and slip the ends of the heaters through each support hole.
8. Install two screws (1), lock washers (2), and flat washers (3) in the heater support (4).
9. See the Wiring Diagram and connect all heater leads at the terminal board (TB2) and remove all tags.

10. Carefully secure wires with the harness clamp (14), screw (15), lock washer (16), and flat washer (17) to the base of the unit.
11. Secure TB3 in place with two screws and lock washers.
12. Secure any loose wiring with tie wraps.

NOTE

FOLLOW-ON MAINTENANCE:
Install Junction Box (WP 0033 00)
Install Top Panels (WP 0016 00)

END OF WORK PACKAGE

UNIT MAINTENANCE
AIR CONDITIONER, HORIZONTAL, COMPACT
(NSN 4120-01-502-1319)
CONDENSER FAN AND MOTOR, INSPECTION, TESTING, REMOVAL, AND INSTALLATION

INITIAL SETUP:**Tools**

Refrigeration Unit Service Tool Kit (WP 0092 00, Item
1)

Materials/Parts

Lock Washers (2)
Tie Down Straps

Equipment Condition**INSPECTION**

1. Check motor rotational freedom by spinning the fan. If there is any stiffness or binding, replace the motor.
2. Check the motor bearings for shaft endplay. If there is excessive endplay, replace the motor.
3. Check the impeller fan for dents and bent or loose fan blades and ensure the hub is securely attached. If damaged, notify Direct Support Maintenance.
4. Check the fan inlet ring for dents or any distortion that would cause interference with the impeller fan. Replace if damaged.

TESTING

1. Use a continuity tester to check the continuity of field coils between motor connector P5 pins A and B and between pins A and C. Continuity should exist.
2. Check the continuity from Pin G to Pins A, B, C, D, and E. Continuity should not exist.
3. Check the continuity of the thermal protectors between pins D and E. If continuity does not exist, allow the motor to cool and then recheck. If continuity continues to cease to exist, replace the motor.

NOTE

If the above inspections and tests are satisfactory but the motor will not operate properly, notify Direct Support Maintenance.

REMOVAL

1. Cut all plastic tie-down straps to free the motor cable.
2. Unscrew the P4, P5, P6, P8, and P9 connectors and push them aside.
3. Loosen setscrew (1) on the fan hub.
4. Remove four cap screws (2) and washers (3) from the top of the motor mounting plate (4).

WARNING

The condenser coil fans are sharp. Injury to personnel can result when removing the motor.

5. Carefully lift the motor (5) to access the bottom of the mounting plate (4).
6. If the motor needs to be replaced, remove four cap screws (6), lock washers (7), eight flat washers (8), mounting plate (4), four bushings (9), and grommets (10).

7. Slide the fan hub off the shaft extension (12) and carefully remove the motor with the shaft extension.
8. Loosen two setscrews (13) on the motor shaft extension (12) at the end of the motor. Slide the shaft extension (12) and the fan from the motor shaft.
9. Remove three screws (14), flat washers (15), and the fan inlet ring (16).

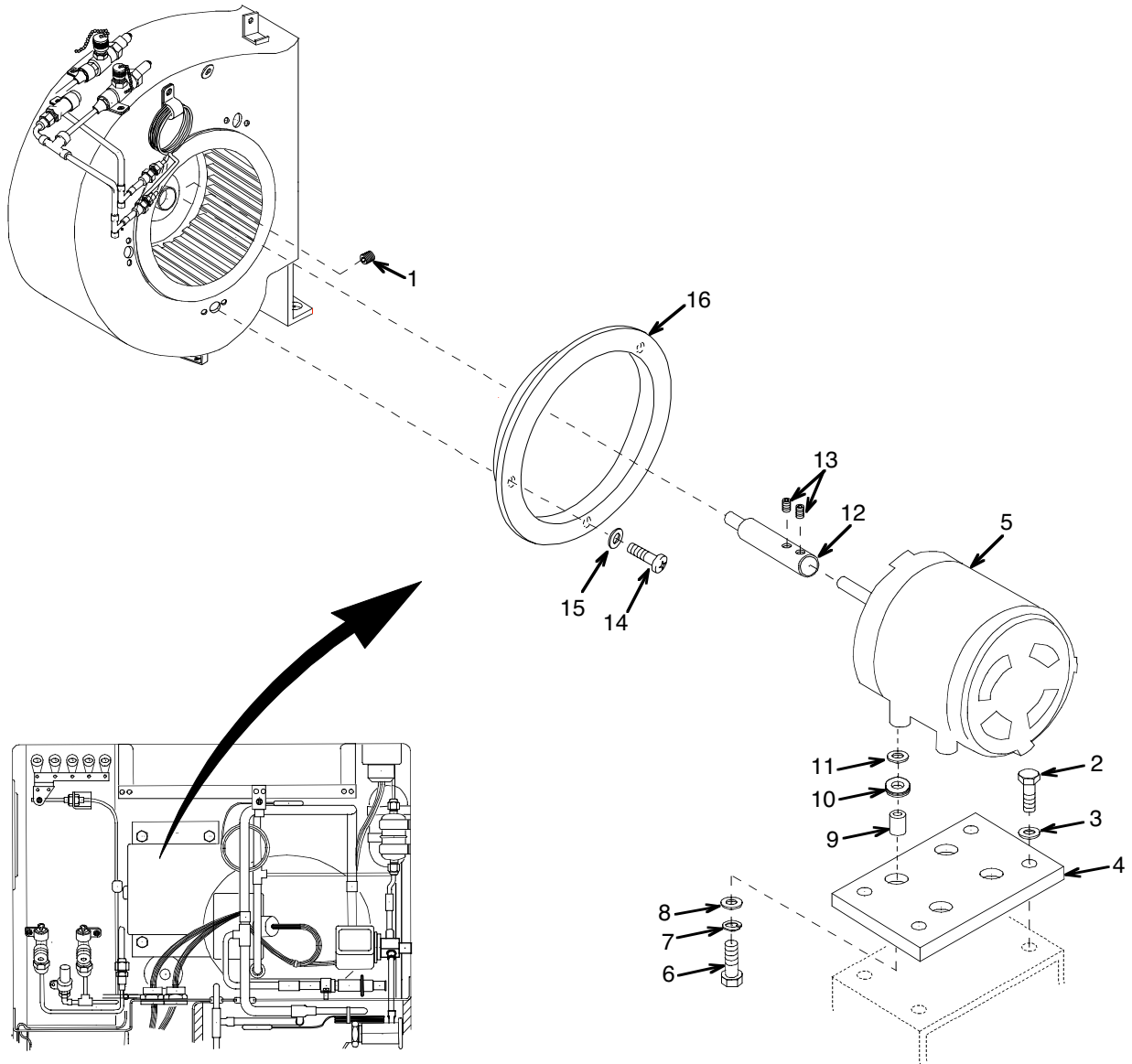

INSTALLATION

1. Install the fan inlet ring (16) and secure with three screws (14) and flat washers (15).
2. Install shaft extension (12) onto motor shaft and secure with two setscrews (13).
3. Install motor w/shaft extension and slide the motor and shaft extension (12) into the hub of the fan impeller. Do not tighten the setscrew (1) at this point.

NOTE

When motor mounting bulbs are up snug, tighten one full turn on each of the four bolts to compress the grommets.

-
4. If necessary, insert four bushings (9) and grommets (10) into four motor mounting holes. Attach the motor (5) to the mounting plate (4) and secure in place with eight flat washers (8), four lock washers (7), and four cap screws (6).
 5. Carefully rotate the motor (5) and mounting plate (3) to align the holes in the mounting plate with those in the unit.
 6. Install four cap screws (2) and washers (3) in the motor mounting plate (4).
 7. Spin the fan by hand and check for equal clearance between the fan inlet ring (16) and the outer edges of the fan. Tighten setscrew (1).
 8. Connect the P4, P5, P6, P8, and P9 connector plugs.
 9. Secure the cable and harness with new plastic tie-down straps.

END OF WORK PACKAGE

UNIT MAINTENANCE
AIR CONDITIONER, HORIZONTAL, COMPACT
(NSN 4120-01-502-1319)
EVAPORATOR COIL INSPECTION AND CLEANING

INITIAL SETUP:**Tools**

Refrigeration Unit Service Tool Kit (WP 0092 00, Item 1)

Scrub Brush (WP 0092 00, Item 2)
Safety Glasses (WP 0092 00, Item 2)

Equipment Condition

Remove Supply Air Louver (WP 0019 00)
Remove Mist Eliminator (WP 0021 00)

WARNING

Compressed air used for cleaning purposes will not exceed 30 psi (2.1 kg/cm).
Do not use steam to clean coil.

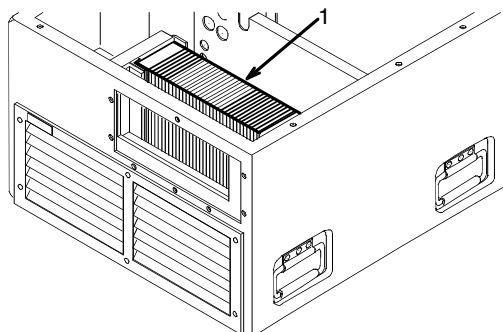
**INSPECTION**

1. Check for and clean dirt that has accumulated on the unit
2. Check the fins for dents, bent edges, or any condition that would block or distort airflow. Straightened all damaged fins with a plastic fin comb.

WARNING

Compressed air used for cleaning purposes will not exceed 30 psi (2.1 kg/cm).
Do not use steam to clean coil.

CLEANING

Clean the coil (1) with a soft bristled brush and use the compressed air at 30 psi (2.1 kg/cm) or less from the inside of the coil to blow the dirt out. Use caution to avoid fin damage. When using compressed air, wear safety glasses or goggles. Dirt can be blown into your eyes. Should a leak or major damage occur, notify your supervisor.

NOTE

FOLLOW-ON MAINTENANCE:
Install Mist Eliminator (WP 0021 00)
Install Supply Air Louver (WP 0019 00)

END OF WORK PACKAGE

UNIT MAINTENANCE
AIR CONDITIONER, HORIZONTAL, COMPACT
(NSN 4120-01-502-1319)
SOLENOID VALVE (COIL) TESTING, REPAIR, REMOVAL, AND INSTALLATION

INITIAL SETUP:**Tools**

Refrigeration Unit Service Tool Kit(WP 0092 00, Item 1)

Materials/Parts

Solenoid Valve Coil
Tie Down Straps

Equipment Condition

Remove Top Rear Panel (WP 0016 00)

WARNING

Do not attempt to disassemble the solenoid valve other than the coil removal with a refrigerant charge in the system. Refrigerant will dangerously be sprayed out if the screws that attach the tube and plunger assembly to the valve body are loose.

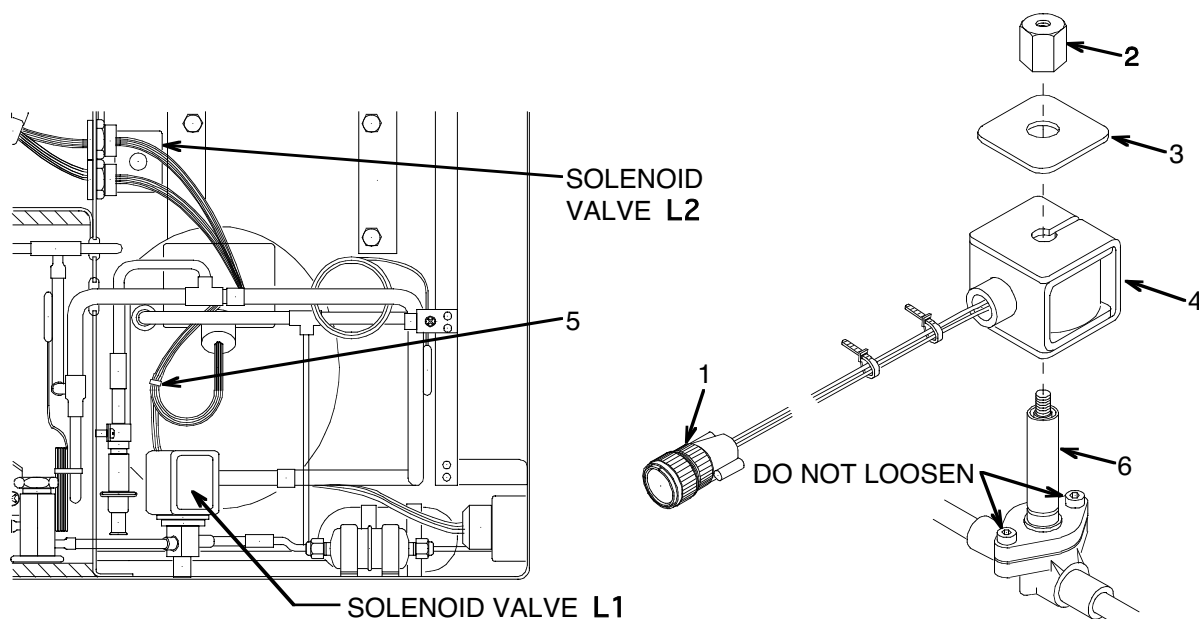
**NOTE**

The following basic instructions apply to both the by-pass solenoid L1 and the pressure equalizer solenoid L2.

TESTING

1. Disconnect the solenoid valve connector plug (1). (P8 for L1 solenoid and P9 for L2 solenoid).
2. Check for continuity between pins A and B in the connector plug (1). If continuity is not found, the coil (4) is open and must be replaced.

Testing - Continued

3. Check for continuity between each pin in the connector plug (1) and coil (4) casing. If continuity is found, the coil is grounded and should be replaced.
4. If continuity checks are satisfactory, apply 28 Volts DC from an external power supply across pins A and B in the connector plug. Listen for a sharp click when the valve changes position. If a click is not heard, internal valve problems are indicated and the entire valve should be replaced. If this occurs, contact your supervisor.

REPAIR

The only authorized repair to the solenoid valve is coil replacement. The coil can be replaced without opening the refrigeration pressure system.

WARNING

Do not attempt to disassemble the solenoid valve, other than coil removal, with a refrigerant charge in the system. Refrigerant can be sprayed dangerously from the unit. Ensure the screws that attach the tube and plunger assembly to the valve body are securely fastened.

REMOVAL

1. Remove the top nut (2), coil (4), data plate (3), and connector plug (1) from the unit.
2. Cut plastic tie-down straps (5) as necessary to remove the solenoid valve cable.
3. Remove the connector plug (1) from the coil (4) leads.

INSTALLATION

1. Attach the connector plug (1) to the coil leads (4).
2. Place the coil assembly (4) and the data plate (3) onto the valve body (6) and secure with a nut (2).
3. Reconnect the connector plug (1).
4. Secure the wires to existing harnesses with new plastic tie-down straps (5).

NOTE

FOLLOW-ON MAINTENANCE:
Install top rear panel (WP 0016 00)

END OF WORK PACKAGE

UNIT MAINTENANCE
AIR CONDITIONER, HORIZONTAL, COMPACT
(NSN 4120-01-502-1319)
LOW PRESSURE CUTOUT SWITCH (LPCO) BYPASS INSTALLATION

INITIAL SETUP:**Tools**

Refrigeration Unit Service Tool Kit (WP 0092 00, Item 1)

Equipment Condition

Remove Junction Box (WP 0033 00)

NOTE

If the unit is to be operated in COOL mode at or below 0 degrees F (-17.8 degrees C), ambient the low pressure cutout (LPCO switch (S5) must be jumped.

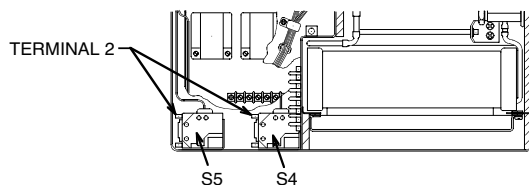
**INSTALLATION**

1. Tag and disconnect all wire leads from the low-pressure cutout switch (S5) terminal 2.
2. Tag and disconnect all wire leads from the high-pressure cutout switch (S4) terminal 2.
3. Connect the wire leads disconnected in step 1, from above, to the high-pressure cutout switch (S4) to terminal 2.
4. Connect the wire leads disconnected in step 2, from above, to the low-pressure cutout switch (S5) to terminal 2.
5. Remove tags.
6. Fabricate the CAUTION tag (as shown below) and place on the control panel to show that the low-pressure cutout switch has been bypassed.

CAUTION

The air conditioner low-pressure cutout switch (S5) has been bypassed to permit operation in COOL mode at temperatures below 0 degrees F. (-17.8 degrees C).

The compressor will not shut off under low suction pressure conditions.

Rewire the pressure cutout switches (S4 and S5) per the wiring diagram when the outside air temperature increases to 40 degrees F (5 degrees C).

NOTE

FOLLOW-ON MAINTENANCE:
Install Junction Box (WP 0033 00)

END OF WORK PACKAGE

UNIT MAINTENANCE
AIR CONDITIONER, HORIZONTAL, COMPACT
(NSN 4120-01-502-1319)
CONDENSER COIL INSPECTION AND CLEANING

INITIAL SETUP:**Tools**

Refrigeration Unit Service Tool Kit (WP 0092 00, Item 1)

Safety Glasses (WP 0092 00, Item 2)
 Scrub Brush (WP 0092 00, Item 2)

Equipment Condition

Remove Top Rear Panel (WP 0016 00)
 Remove Condenser Air Inlet Guard (WP 0017 00)

WARNING

Compressed air used for cleaning purposes will not exceed 30 psi (2.1 kg/cm).
 Do not use steam to clean coil.

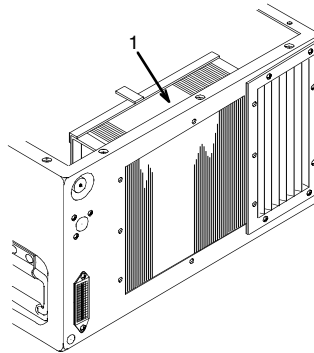
**NOTE**

Six screws located on the vertical frames of the condenser air inlet guard secure the condenser coil to the air conditioner housing.

INSPECTION

1. Check for and clean accumulated dust or dirt from the unit.
2. Check fins for dents, bent edges, or any condition that would block or distort the airflow. Straighten all damaged fins with a plastic fin comb.

CLEANING

Clean the coil with a soft bristled brush and use compressed air at 30 PSI or less from the inside of the coil to blow out any dirt. Use care to avoid fin damage. When using compressed air, wear safety glasses or goggles. Dirt can be blown into your eyes. Should a leak or major damage occur, notify your supervisor.

NOTE

FOLLOW-ON MAINTENANCE:
 Install Condenser Air Inlet Guard (WP 0017 00)
 Install Top Rear Panel (WP 0016 00)

END OF WORK PACKAGE

UNIT MAINTENANCE
AIR CONDITIONER, HORIZONTAL, COMPACT
(NSN 4120-01-502-1319)
CONNECTORS INSPECTION AND REPLACEMENT

INITIAL SETUP:**Tools**

Refrigeration Unit Service Tool Kit (WP 0092 00, Item 1)

Equipment Condition

Disconnect power at the power source

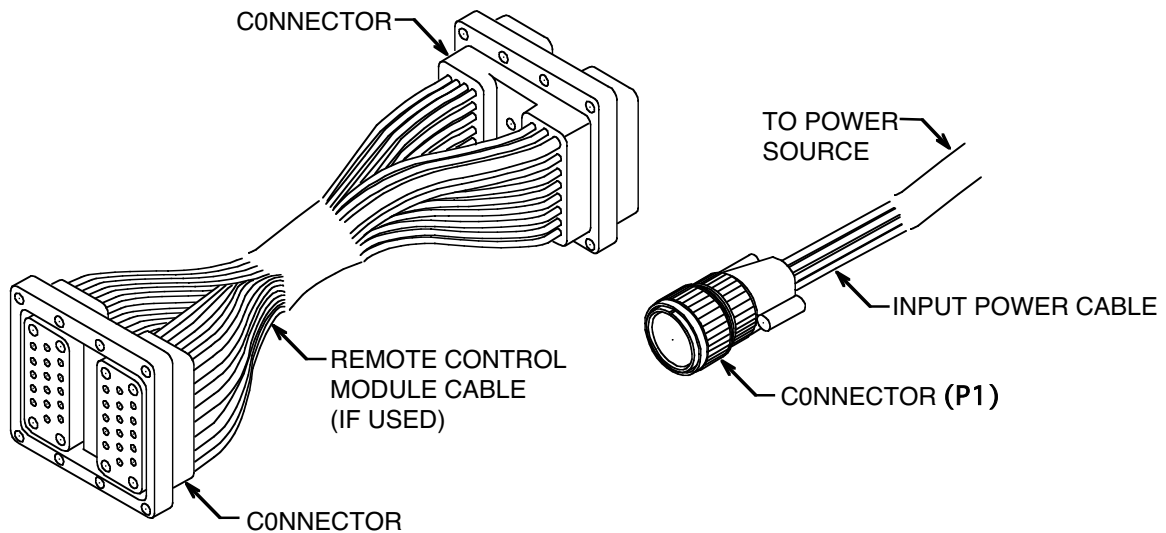
**NOTE**

There are three connectors supplied with each air conditioner.

The input power cable connector (P1) is used at the unit end of the input power cable. It can be connected to the J1 receptacle located above the control module of the J11 receptacle, which is located on the upper-left rear corner of the unit.

The remaining two remote control module cable connectors are used when the control module is to be installed remote from the air conditioner.

INSPECTION

Check for any loose, missing, or damaged pins and cut or broken wires on the connector.

REPLACEMENT

Replace damaged wires or connectors and wires with missing, loose, or damaged pins.

NOTE

FOLLOW-ON MAINTENANCE:
 Connect power at the power source

END OF WORK PACKAGE

UNIT MAINTENANCE
AIR CONDITIONER, HORIZONTAL, COMPACT
(NSN 4120-01-502-1319)
INSTALLATION HARDWARE INSPECTION AND REPLACEMENT

INITIAL SETUP:**Tools**

Refrigeration Unit Service Tool Kit (WP 0092 00, Item
1)

Equipment Condition

Disconnect power at the power source

NOTE

Each unit is supplied with mounting hardware for the four base attachment points.

INSPECTION

Inspect hardware to ensure it is tight, properly installed, and in good condition.

REPLACEMENT

Replace missing, damaged, or defective parts.

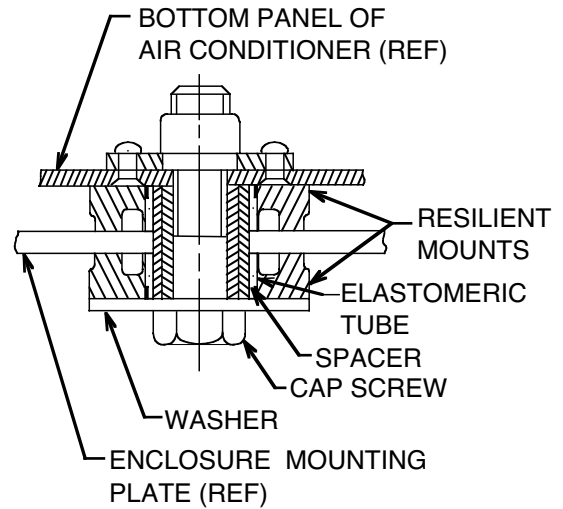
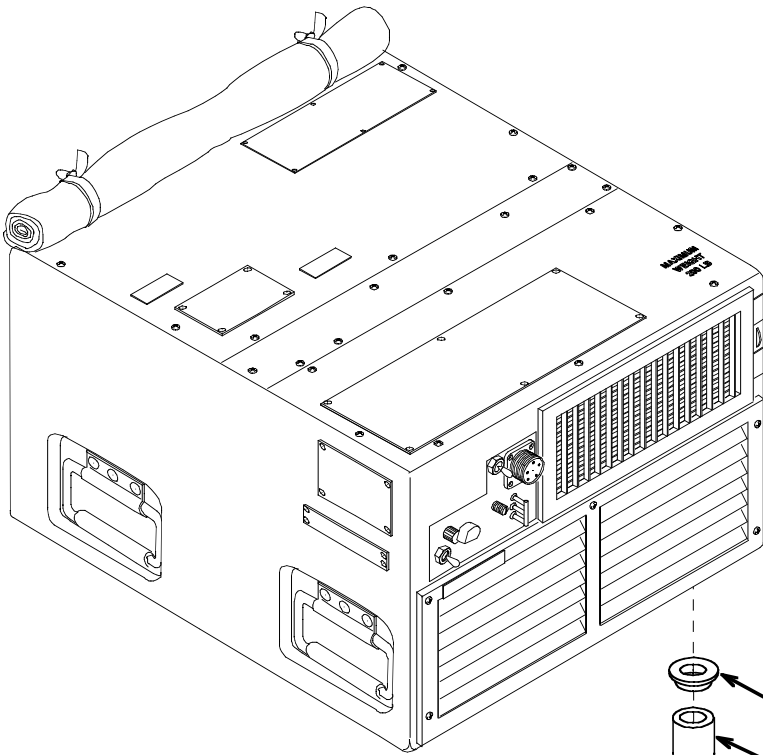

CROSS SECTION OF BOTTOM MOUNTING HOLE AND HARDWARE (TYPICAL 4 PLACES)

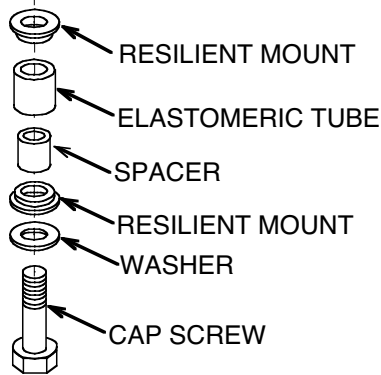

NOTE

FOLLOW-ON MAINTENANCE:
Connect power at the power source

END OF WORK PACKAGE

CHAPTER 8.

DIRECT SUPPORT MAINTENANCE INSTRUCTIONS

DIRECT SUPPORT MAINTENANCE
AIR CONDITIONER, HORIZONTAL, COMPACT
(NSN 4120-01-502-1319)
GENERAL MAINTENANCE INSTRUCTIONS

WARNING

High voltage in the air conditioner can cause death or serious injury. Disconnect power from the air conditioner before conducting any maintenance work to the electrical system.

The procedures in this section have been arranged so that the items appear in the direct (F) maintenance level column on the Maintenance Allocation Chart (MAC), is provided in WP 0092 00. Step-by-step procedures have been provided for all action authorized to be performed by direct maintenance in the order in which they appear on the MAC. Actions authorized to be performed by organizational and general support maintenance have been duly noted; step-by-step procedures for these actions may be found in Chapters 7 and 9 respectively.

DIRECT SUPPORT MAINTENANCE
AIR CONDITIONER, HORIZONTAL, COMPACT
(NSN 4120-01-502-1319)
TOP PANELS REPAIR AND REPLACEMENT

INITIAL SETUP:**Tools**

Refrigeration Unit Service Tool Kit (WP 0092 00, Item 1)

Materials/Parts

Adhesive Remover
Adhesive (WP 0094 00, Item 2)
Insulation Tape (WP 0094 00, Item 18)

Equipment Condition

Remove Top Panels (WP 0016 00)

WARNING

Adhesive remover is flammable and the vapors can be explosive. Repeated or prolonged skin contact or inhalation of vapors can be toxic. Use a well-ventilated area, wear gloves, and keep away from sparks or flame.

NOTE

Authorized repairs for these panels include replacement of gaskets, insulation, and information plates

Use gasket material insulation material, or nameplates identified in TM9-4120-400-24P only.

REPAIR

1. Remove as much old gasket or insulation material as possible by pulling or scraping it away from the metal surface.

WARNING

Adhesive remover is flammable and the vapors can be explosive. Repeated or prolonged skin contact or inhalation of vapors can be toxic. Use a well-ventilated area, wear gloves, and keep away from sparks or flame.

2. Soften and remove old adhesive and material residue using adhesive remover and a stiff brush.
3. Fabricate gaskets/insulation in accordance with the dimensions provided in WP 0094 00.
4. Coat the mating surfaces of the metal and material with adhesive. Let both surfaces air dry until the adhesive is tacky, but will not stick to fingers.
5. Starting with an end, carefully attach material to the metal. Press firmly to seal parts together.
6. Minor dents and bent edges can be straightened using common sheet metal repair procedures.
7. Refer to TM 43-0139 to touch up or refinish the unit.

REPLACEMENT

Replace all panels that are badly dented, bent, or punctured.

NOTE

FOLLOW-ON MAINTENANCE:
Install Top Panels (WP 0016 00)

END OF WORK PACKAGE

DIRECT SUPPORT MAINTENANCE
AIR CONDITIONER, HORIZONTAL, COMPACT
(NSN 4120-01-502-1319)

FRESH AIR DAMPER AND ACTUATOR REMOVAL, REPLACEMENT, INSTALLATION, AND ADJUSTMENT

INITIAL SETUP:

Tools

Refrigeration Unit Service Tool Kit (WP 0092 00, Item 1)

Materials/Parts

Self-Locking Nuts (2)
 Lock Washer
 Lock Washers (3)

Spring Washers (2)
 Push On Nut

Equipment Condition

Remove Return Air Louver (WP 0018 00)
 Remove Supply Air Louver (WP 0019 00)
 Remove Mist Eliminator (WP 0021 00)
 Remove Compressor (WP 0030 00)

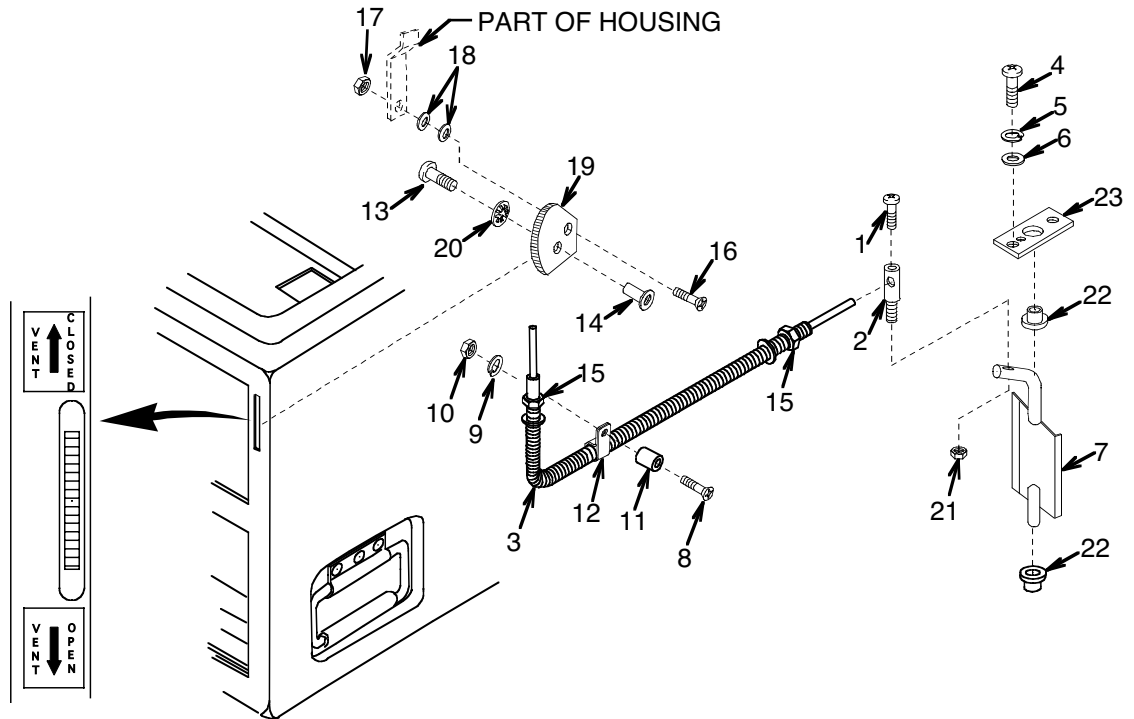

REMOVAL

1. Loosen machine screw (1) on threaded posts (2) and disconnect the push-pull control cable assembly (3).
2. Remove two machine screws (4), lock washers (5), and flat washers (6). Lift damper (7) from the air conditioner.
3. Remove screw (8), lock washer (9), nut (10), spacer (11), and loop clamp (12).

4. Loosen the screw (13) in the actuator plate blind nut (14) in order to free the end of the push-pull control cable (3).
5. Remove outer nuts (15) from both ends of the push-pull control cable (3) and remove the cable from the unit.
6. Remove screw (16), self-locking nut (17), two spring washers (18), and the actuator plate (19).
7. Remove screw (13), push-on nut (20), and blind nut (14) from the actuator plate (19).
8. Remove self-locking nut (21), screw (1), mechanical post (2), two sleeve bearings (22), and the cover (23) from the damper (7).

REPLACEMENT

Replace all worn or damaged parts.

INSTALLATION

1. Insert a blind nut (14) into the actuator plate (19) and secure it with the push on nut (20).
2. Install screw (13) into the blind nut (14). Do not tighten.
3. Attach two sleeve bearings (22), cover (23), mechanical post (2), and self-locking nut (21) to the damper (7).
4. Install machine screw (1) into the threaded post (2). Do not tighten.
5. Install the actuator plate (19) with the screw (16), two spring washers (18), and self-locking nut (17).
6. Install the damper (7) into the opening of the housing.
7. Secure the damper cover (23) to the housing with two screws (4), lock-washers (5), and flat washers (6).
8. Install one nut (15) approximately seven turns onto each end of the push-pull control cable (3).
9. Install the ends of the cable through the openings in the housing.
10. Install the outer nuts (15) on the push-pull control cable (34) and tighten.
11. Insert the cable (3) ends into the mechanical post (2) and blind nut (14).
12. Install the loop clamp (12), spacer (11), screw (8), nut (10), and washer (9).

NOTE

Be sure equal lengths of the push-pull control cable (3) extend from the ends.

13. Pull the actuator plate (19) in the center position and tighten the screw (13).
14. Put the damper (7) in the center position and tighten the screw.

ADJUSTMENT

1. Loosen the screw (13) on the blind nut (14) to release the end of the push-pull control cable.
2. Move the push-pull cable (3) in and out. Determine the center between the two most extreme stop points.
3. Move the actuator plate (19) so that it is also centered on the curved position of the plate.
4. Tighten the screw (13) on the blind nut (14).
5. Check the actuator plate (19) for smooth operation.

NOTE

FOLLOW-ON MAINTENANCE:
Install Compressor (WP 0030 00)
Install Mist Eliminator (WP 0021 00)
Install Supply Air Louver (WP 0019 00)
Install Return Air Louver (WP 0018 00)

END OF WORK PACKAGE

DIRECT SUPPORT MAINTENANCE
AIR CONDITIONER, HORIZONTAL, COMPACT
(NSN 4120-01-502-1319)
CONDENSER FAN AND HOUSING REMOVAL AND INSTALLATION

INITIAL SETUP:

Tie Down Straps

ToolsRefrigeration Unit Service Tool Kit (WP 0092 00, Item
1)**Equipment Condition**Remove Condenser Coil (WP 0082 00)
Remove Condenser Fan Motor and Inlet Ring (WP
0047 00)**Materials/Parts**

Lock Washers (2)

REMOVAL**CAUTION**

Refrigeration tubing is delicate and may break if not handled properly. Use caution when handling the refrigeration tubing.

1. Remove three screws (1), lock washers (2), flat washers (3), securing loop clamps, charging valves, and pressure relief valve to the condenser fan housing.
2. Remove the screw (4) and lock washer (5) that secure the clamp and tubing to the fan housing.
3. Remove five screws (6) attaching the condenser fan housing to the unit. Screws are accessible from underneath the unit.
4. Carefully remove the condenser fan housing (7) with the fan (8) inside by rotating the housing 90 degrees counterclockwise and pulling it straight out.
5. Remove the fan (8) from the condenser fan housing (7).

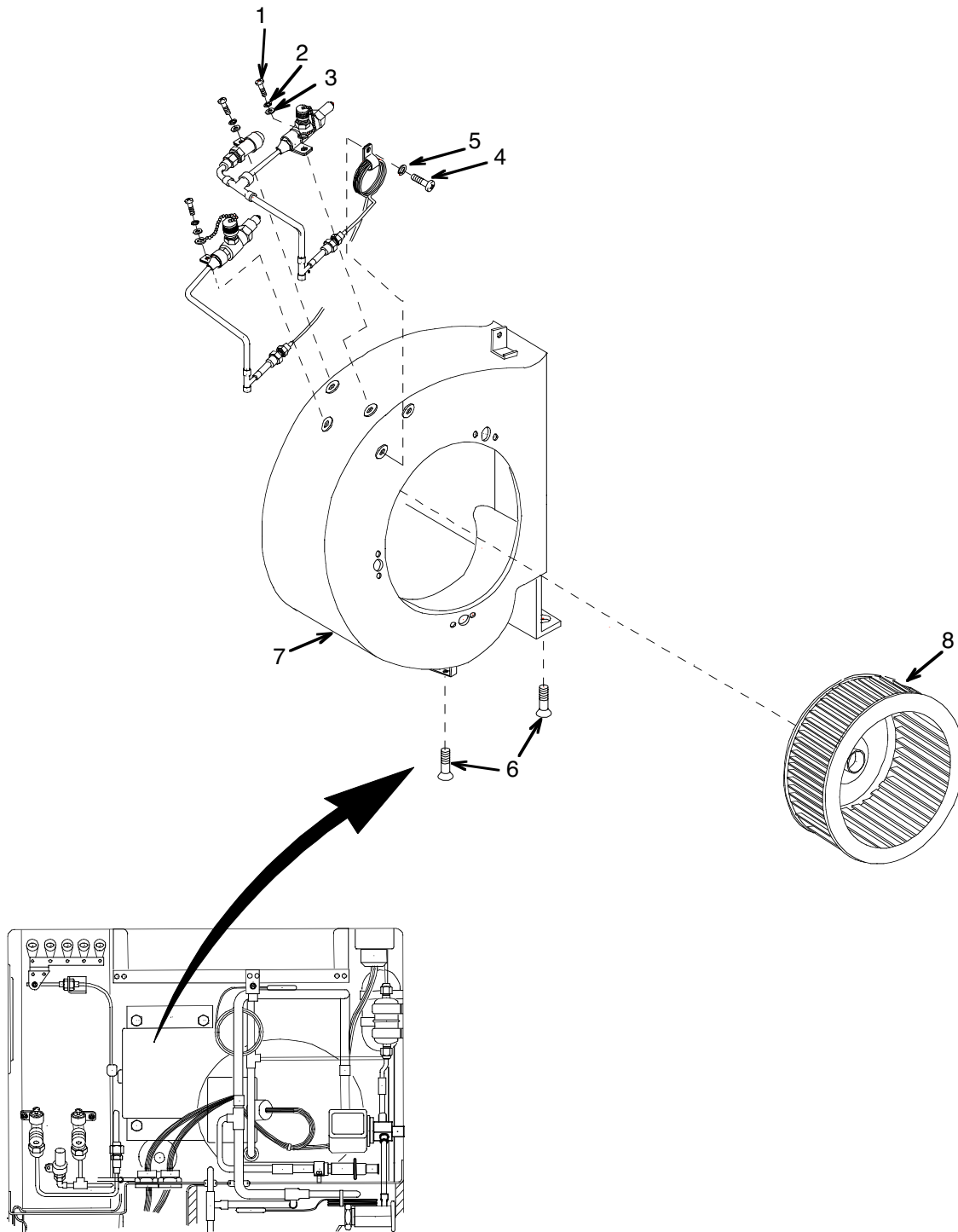

INSTALLATION

1. Install the impeller fan (8) into the condenser fan housing (7).
2. Carefully place the condenser fan housing (7) in the unit by rotating the housing 90 degrees counterclockwise and slide into place.
3. Secure the condenser fan housing (7) to the unit with five attaching screws (6).

CAUTION

Refrigeration tubing is delicate and may break if not handled properly. Use caution when handling the refrigeration tubing.

4. Secure the clamp and tubing to the fan housing with the screw (4) and lock washer (5).
5. Secure loop clamps with two charging valves and pressure relief valve to the condenser fan housing (7) using three screws (1), flat washers (2), and lock washers (3).

NOTE

FOLLOW-ON MAINTENANCE:
Install Condenser Coil (WP 0082 00)
Install Condenser Motor (WP 0047 00)

END OF WORK PACKAGE

DIRECT SUPPORT MAINTENANCE
AIR CONDITIONER, HORIZONTAL, COMPACT
(NSN 4120-01-502-1319)
SCREENS, GUARDS, AND LOUVERS REPAIR AND REPLACEMENT

INITIAL SETUP:**Tools**

Refrigeration Unit Service Tool Kit (WP 0092 00, Item 1)

Materials/Parts

Adhesive Remover

Adhesive (WP 0094 00, Item 2)
 Gasket (WP 0094 00)

Equipment Condition

Remove Rear Screens and Guards (WP 0017 00)
 Remove Return Air Louver and Air Filter (WP 0018 00)
 Remove Supply Air Louver (WP 0019 00)

NOTE

Replacing gaskets and straightening bent blades are the only authorized repairs.

REPAIR

1. Remove as much old gasket material as possible by pulling or scraping it away from the metal surface.

WARNING

Adhesive remover is flammable and the vapors can be explosive. Repeated or prolonged skin contact or inhalation of vapors can be toxic. Use in a well-ventilated area, wear protective gloves, and keep away from sparks or flame.

2. Use adhesive remover and a stiff brush to soften and remove old adhesive and gasket residue.
3. Fabricate all gaskets in accordance with the Parts Manual.
4. Coat all mating surfaces of both metal and gasket with adhesive. Allow both surfaces to air dry until the adhesive is tacky, but will not stick to fingers.
5. Starting on one end, carefully, but firmly, attach the gasket to the metal.
6. Straighten minor dents and bent edges using common sheet metal repair procedures.
7. Straighten any slightly bent louver blades by hand.
8. See TM 43-0139 for touch-up or refinishing procedures.

REPLACEMENT

Replace screens, guards, or louvers that are badly dented or bent and screens that are punctured or torn.

NOTE

FOLLOW-ON MAINTENANCE:
 Install Supply Air Louver (WP 0019 00)
 Install Return Air Louver and Air Filter (WP 0018 00)
 Install rear screens and guards (WP 0017 00)

END OF WORK PACKAGE

DIRECT SUPPORT MAINTENANCE
AIR CONDITIONER, HORIZONTAL, COMPACT
(NSN 4120-01-502-1319)
SERVICE MANIFOLD REMOVAL AND INSTALLATION

INITIAL SETUP:

Tools

Refrigeration Unit Service Tool Kit (WP 0092 00, Item 1)

Goggles (WP 0092 00, Item 2)
 Gloves (WP 0092 00, Item 2)

Equipment Condition

Disconnect power at the source

WARNING

Dangerous Pressurized Chemical Refrigerant is used in the operation of this equipment

Avoid contact with liquid refrigerant or inhaling refrigerant gas being discharged from any container under pressure. Sudden and irreversible tissue damage can result from freezing. Wear thermal protective gloves and a face protector or safety glasses in any situation where skin or eye contact is possible.

Heat causes the refrigerant to break down and form carbonyl chloride (phosgene), a highly toxic and corrosive gas. Prevent contact of refrigerant gas with a flame or other hot surfaces.

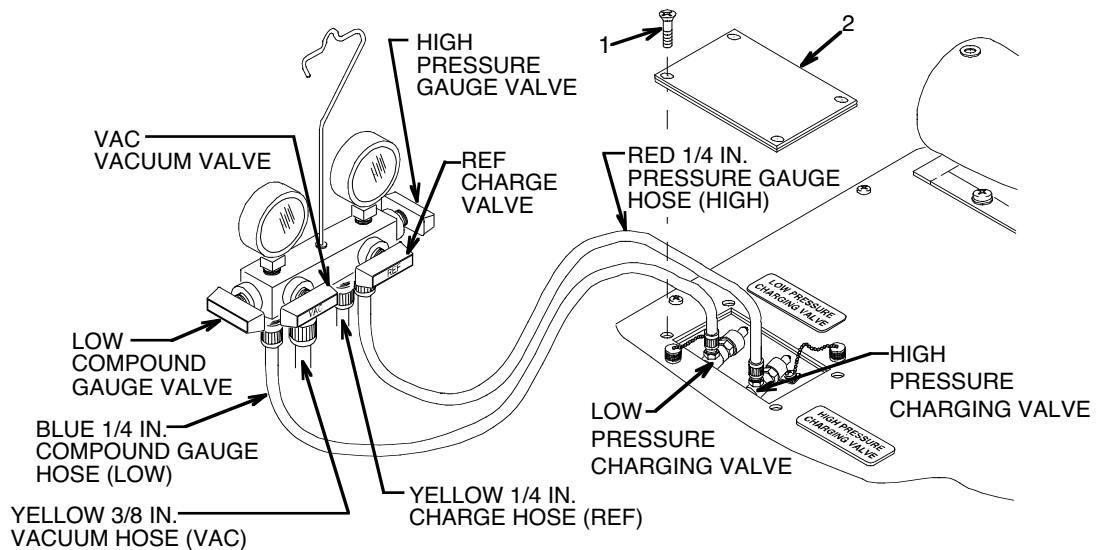

WARNING

Dangerous Pressurized Chemical Refrigerant is used in the operation of this equipment

Use great care to avoid contact with the liquid refrigerant or inhaling refrigerant gas that is discharged from any container that is pressurized. Sudden and irreversible tissue damage can result from freezing. Wear thermal protective gloves and a face protector or safety glasses in any situation when skin or eye contact is possible.

Prevent contact of refrigerant gas with a flame or other hot surfaces. Heat causes the refrigerant to break down and form carbonyl chloride (phosgene), a highly toxic and corrosive gas. Unit contains R-22, a chemical substance that harms public health and the environment by destroying ozone in the upper atmosphere. Qualified personnel must service equipment only.

INSTALLATION

1. Remove four screws and (1) the access panel (2).
2. Check that the HIGH and LOW PRESSURE CHARGING VALVES are closed.
3. Remove the protective caps from the HIGH and LOW PRESSURE CHARGING VALVES.
4. Connect the red hose (pressure gauge) to the High pressure charging valve and the blue (compound gauge) hose to the LOW pressure-charging valve.
5. Check that all four service manifold valves are closed.
6. Open the HIGH and LOW-pressure charging valves.
7. Loosen the red hose (pressure gauge) at the service manifold and allow the refrigerant to purge for 3-5 seconds. Tighten hose.
8. Loosen the blue hose (compound gauge) at the service manifold and allow the refrigerant to purge for 3-5 seconds. Tighten hose.

REMOVAL

1. Check that the unit HIGH and LOW pressure charging valves are closed.
2. Open all four of the service manifold valves to bleed off pressure.
3. Remove hoses from HIGH and LOW pressure charging valves.
4. Close the service manifold valves.
5. Install protective caps onto the HIGH and LOW pressure charging valves.
6. Install the access panel (2) and secure with four screws.

NOTE

FOLLOW-ON MAINTENANCE:
Connect power at the source.

END OF WORK PACKAGE

DIRECT SUPPORT MAINTENANCE
AIR CONDITIONER, HORIZONTAL, COMPACT
(NSN 4120-01-502-1319)
DISCHARGING THE REFRIGERANT SYSTEM

INITIAL SETUP:

Tools:

Tool Kit, Service, Refrigeration Unit (WP 0092 00, Item 1)
 Goggles (WP 0092 00, Item 2)

Gloves (WP 0092 00, Item 2)
 Refrigerant Recovery and Recycle Unit

Equipment Condition

Install the service manifold
 (WP 0059 00)

WARNING

Dangerous Pressurized Chemical Refrigerant is used in the operation of this equipment

Use great care to avoid contact with the liquid refrigerant or inhaling refrigerant gas that is discharged from any container that is pressurized. Sudden and irreversible tissue damage can result from freezing. Wear thermal protective gloves and a face protector or safety glasses in any situation when skin or eye contact is possible.

Prevent contact of refrigerant gas with a flame or other hot surfaces. Heat causes the refrigerant to break down and form carbonyl chloride (phosgene), a highly toxic and corrosive gas. Unit contains R-22, a chemical substance that harms public health and the environment by destroying ozone in the upper atmosphere. Qualified personnel must service equipment only.

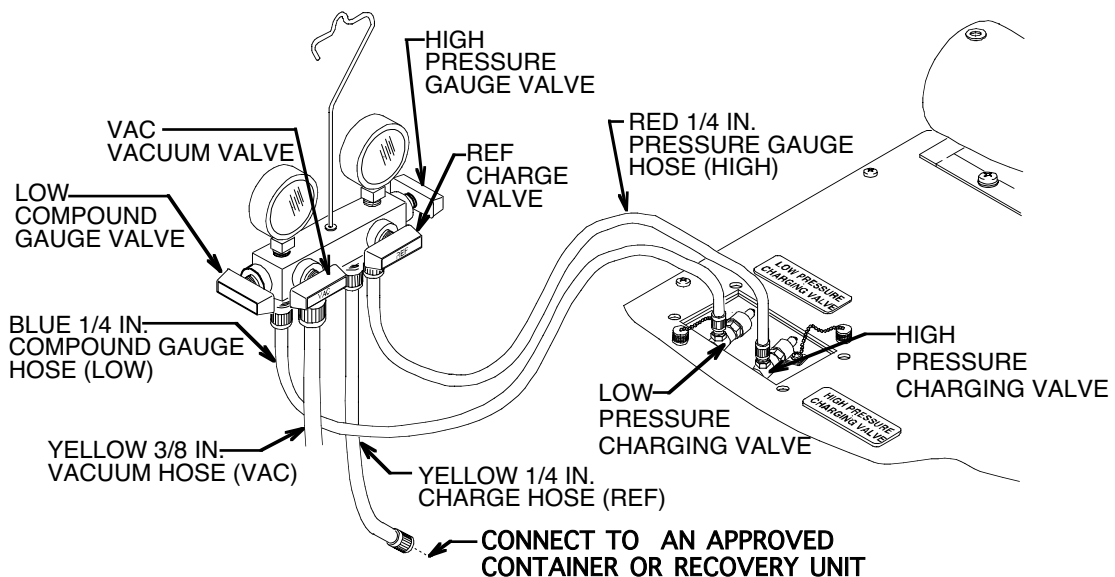

WARNING

Dangerous Pressurized Chemical Refrigerant is Used When Operating Equipment

Use great care to avoid contact with the liquid refrigerant or inhaling refrigerant gas that is discharged from any container that is pressurized. Sudden and irreversible tissue damage can result from freezing. Wear thermal protective gloves and a face protector or safety glasses in any situation when skin or eye contact is possible.

Prevent contact of refrigerant gas with a flame or other hot surfaces. Heat causes the refrigerant to break down and form carbonyl chloride (phosgene), a highly toxic and corrosive gas. Unit contains R-22, a chemical substance that harms public health and the environment by destroying ozone in the upper atmosphere. Qualified personnel must service equipment only.

NOTE

In accordance with Environmental Protection Agency regulations, refrigerants cannot be discharged into the atmosphere. A refrigerant recovery /recycling unit must be used whenever discharging the refrigeration system.

DISCHARGING

WARNING

Dangerous Pressurized Chemical Refrigerant is used in the operation of this equipment.

Use great care to avoid contact with the liquid refrigerant or inhaling refrigerant gas that is discharged from any container that is pressurized. Sudden and irreversible tissue damage can result from freezing. Wear thermal protective gloves and a face protector or safety glasses in any situation when skin or eye contact is possible.

Prevent contact of refrigerant gas with a flame or other hot surfaces. Heat causes the refrigerant to break down and form carbonyl chloride (phosgene), a highly toxic and corrosive gas. Unit contains R-22, a chemical substance that harms public health and the environment by destroying ozone in the upper atmosphere. Qualified personnel must service equipment only.

NOTE

In accordance with Environmental Protection Agency regulations, refrigerants cannot be discharged into the atmosphere. A refrigerant recovery /recycling unit must be used whenever discharging the refrigeration system.

1. Connect the 1/4 inch yellow hose (charge) to an approved refrigerant recovery/recycling unit.

CAUTION

Loss of oil could result in compressor damage. Be sure to follow instructions for specific container or refrigerant recovery unit being used to avoid compressor oil loss.

2. Open the pressure gauge and compound gauge valves.

NOTE

Authorized personnel must operate the recovery/recycling unit only.

3. Operate the recovery/recycling unit in accordance with the manufacturer's instruction.

NOTE

FOLLOW-ON MAINTENANCE:
Remove service manifold (WP 0059 00)

END OF WORK PACKAGE

DIRECT SUPPORT MAINTENANCE
AIR CONDITIONER, HORIZONTAL, COMPACT
(NSN 4120-01-502-1319)
PURGING THE REFRIGERANT SYSTEM

INITIAL SETUP:**Tools**

Refrigeration Unit Service Tool Kit (WP 0092 00, Item 1)

Goggles (WP 0092 00, Item 2)

Nitrogen Regulator (WP 0092 00, Item 6)

Materials/Parts

Nitrogen (WP 0094 00, Item 8)

Equipment Condition

Discharge refrigerant system (WP 0060 00)

Remove service manifold (WP 0059 00)

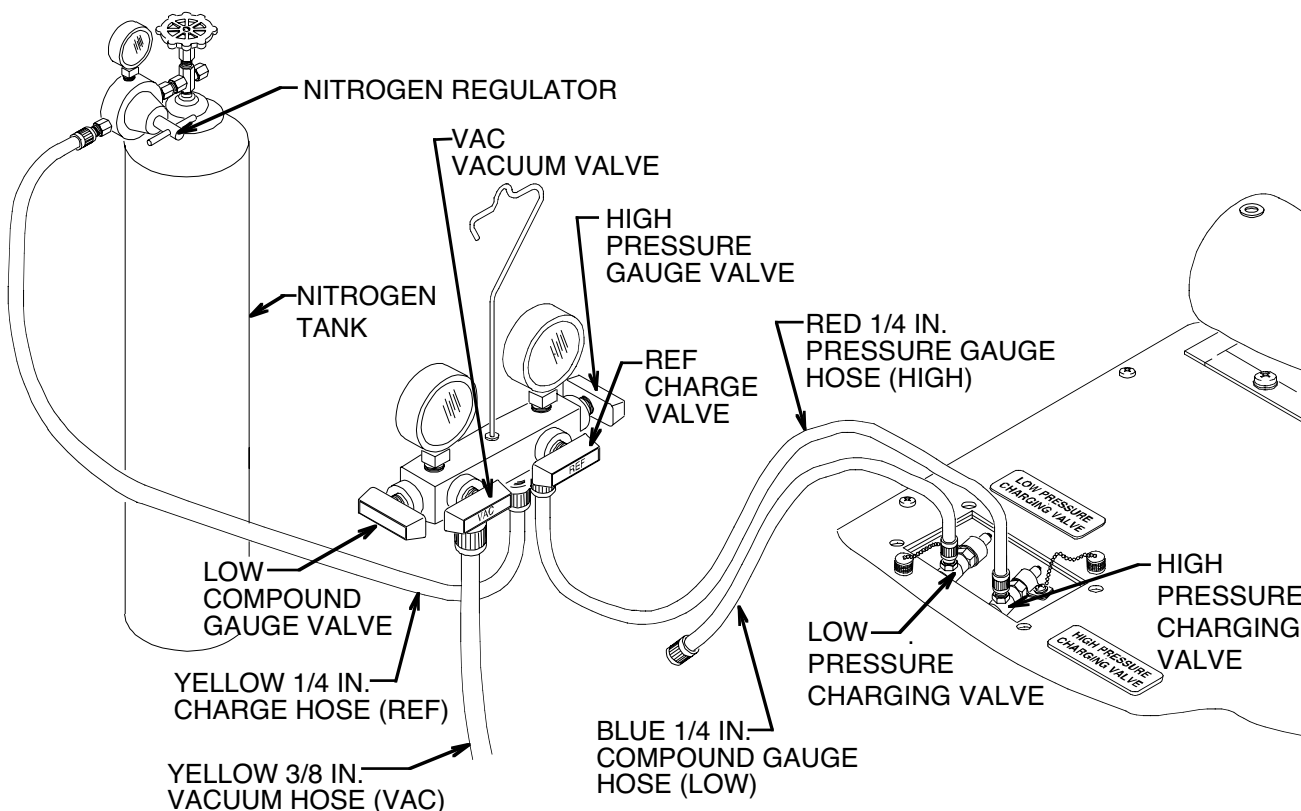
**WARNING**

The pressure in a nitrogen cylinder can exceed 2000 psi. A nitrogen pressure regulator should be used at all times to avoid personal injury.

Nitrogen is an inert gas that can cause suffocation and must be discharged in a well-ventilated area.

1. Connect the 1/4 inch yellow hose (charge) to a nitrogen regulator and dry nitrogen cylinder.
2. Disconnect the blue hose (compound gauge) hose from the service manifold.
3. Be sure that the service manifold compound gauge and the vacuum valves are closed.

Purging the Refrigerant System - Continued

4. Be sure that the unit's HIGH and LOW pressure charging valves are open.
5. Open the service manifold pressure gauge and charge valves.
6. Open the nitrogen cylinder valve and adjust the regulator. Approximately 1 – 2 cfm (0.028 – 0.057 m³/minute of nitrogen will flow through the system.
7. Check for discharge from the blue hose attached to the LOW pressure-charging valve. Be sure that no oil is being forced out of the system.
8. When purging is completed, close the nitrogen cylinder valve.
9. Disconnect the 1/4 inch yellow hose (charge) from the nitrogen regulator.
10. Connect the blue hose (compound gauge) to the service manifold.

NOTE

FOLLOW-ON MAINTENANCE:
Install service manifold (WP 0059 00)

END OF WORK PACKAGE

DIRECT SUPPORT MAINTENANCE
AIR CONDITIONER, HORIZONTAL, COMPACT
(NSN 4120-01-502-1319)
BRAZING, DEBRAZING, AND CLEANING PROCEDURES

INITIAL SETUP:**Tools**

Refrigeration Unit Service Tool Kit (WP 0092 00, Item 1)
Goggles (WP 0092 00, Item 2)
Gloves (WP 0092 00, Item 2)

Abrasive Cloth (WP 0094 00, Item 12)
Rags (WP 0094 00, Item 13)

Equipment Condition

Discharge refrigerant system (WP 0060 00)
Remove Service Manifold (WP 0059 00)

Materials/Parts

Brazing Alloy (WP 0094 00, Items 9 and 10)
Brazing Flux (WP 0094 00, Item 11)

WARNING

The polyurethane foam used as insulation in the air conditioner will break down to form toxic gasses if exposed to the flame of a torch or brazing temperature.

Never use a heating torch on any part that contains refrigerant. Heat will cause the refrigerant to break down and form carbonyl chloride (phosgene), a highly toxic and corrosive gas. All of the refrigerant must be discharged from the system. The entire system must be purged with dry nitrogen before beginning any debrazing operation.

DEBRAZING

1. Be sure the work area is well ventilated and that dry nitrogen is flowing through the refrigeration system at a rate of 1 – 2 cfm (0.028 – 0.057 m³/minute).

WARNING

The polyurethane foam, used as insulation in the air conditioner, will break down to form toxic gases if exposed to the flame of a torch or brazing temperature.

2. Protect the insulation, wiring harnesses, and other components with the appropriate shields.

WARNING

Never use a heating torch on any part that contains refrigerant. Heat will cause the refrigerant to break down and form carbonyl chloride (phosgene), a highly toxic and corrosive gas. All of the refrigerant must be discharged from the system. The entire system must be purged with dry nitrogen before beginning any debrazing operation.

NOTE

It may be easier to access a component by cutting or debrazing the copper lines in the accessible areas and by removing part of the interconnecting tubing with the component.

3. When debrazing a joint on a valve, disassemble the valve to the extent possible and wrap all but the joint with a wet cloth to act as a heat sink.
4. Apply sufficient heat uniformly around the joint to quickly melt the filler alloy. If heat is applied slowly or on one side, the entire component or length of tubing will be heated. The filler alloy in adjacent joints may also be melted. Remove heat as soon as the joint is separated.

CLEANING

The entire filler alloy must be cleaned from debrazed joints before reassembly. Heat each piece of the joint until the filler alloy is melted, then wipe it away with a wire brush. Be sure that no filler alloy or other debris is left inside any tubing, fitting, or component.

BRAZING

1. Be sure the work area is well ventilated. Dry nitrogen should be flowing through the refrigeration system at a rate of 1 – 2 cfm (0.028 – 0.057 m³/minute).

WARNING

The polyurethane foam, used as insulation in the air conditioner, will break down to form toxic gasses if exposed to the flame of a torch or brazing temperature.

2. Protect the insulation, wiring harnesses, and other components with appropriate shields.

WARNING

Never use a heating torch on any part that contains refrigerant. Heat will cause the refrigerant to break down and form carbonyl chloride (phosgene), a highly toxic and corrosive gas. All of the refrigerant must be discharged from the system. The entire system must be purged with dry nitrogen before beginning any debrazing operation.

NOTE

All joints, except those provided with flare fittings, are made by brazing in accordance with MIL-B-7883. Radiographic examination is not required.

Grade IV or VI brazing alloy and Tube B flux, as specified in MIL-B-7883, must be used for all copper to brass joints. Grade III brazing alloy may be substituted for Grade IV or VI for copper-to-copper joints. Flux is not required for copper-to-copper joints.

3. When brazing a joint on a valve, disassemble the valve to the extent possible and wrap all but the joint with a wet cloth (to act as a heat sink).

NOTE

If interconnected tubing was removed with a component, braze the tubing to the new components before installation.

4. Position the component or assembly into place.
5. To quickly melt the filler alloy, apply sufficient heat evenly around the joint. If heat is applied slowly or on one side, the entire component or length of tubing will be heated. Filler alloys in adjacent joints may also be melted. Remove heat as soon as brazing is completed.

NOTE

FOLLOW-ON MAINTENANCE:
Remove service manifold (WP 0059 00)

END OF WORK PACKAGE

DIRECT SUPPORT MAINTENANCE
AIR CONDITIONER, HORIZONTAL, COMPACT
(NSN 4120-01-502-1319)
FLUSHING THE REFRIGERANT SYSTEM

INITIAL SETUP:**Tools**

Refrigeration Unit Service Tool Kit (WP 0092 00, Item 1)
 Goggles (WP 0092 00, Item 2)
 Gloves (WP 0092 00, Item 2)
 Power Supply (WP 0092 00, Item 3)
 Diaphragm Pump

Materials/Parts

Refrigerant R-114 (WP 0094 00, Item 5)

Equipment Condition

Remove Compressor (WP 0030 00)

FLUSHING**CAUTION**

When a hermetic motor burns out, the stator winding decomposes forming carbon, water, and acid, which contaminate refrigerant systems. These contaminants must be thoroughly removed from the system to prevent repeated motor failures.

Unit contains R-22, a chemical substance that harms public health and the environment by destroying ozone in the upper atmosphere. Qualified personnel must service equipment only.

Flush the refrigerant system with refrigerant solvent R-114. Flushing should be done under a pressure of 8 to 12 psi (.56 to .84 kg/cm²). Procedures for flushing the system are as follows:

1. Connect the discharge line of the pump to the tubing at point 1. Connect the recovery line to the tubing at point 2. Leave the suction line service valve (point 3) and discharge the line service valve (point 6) closed. Cap the tubing at points 4 and 5.
2. Start the pump and flush the line for approximately 10 minutes and then turn the pump off.
3. Remove the recovery line from point 2 and cap the tubing (at point 2).
4. Connect the recovery line to the valve at point 3 and open the suction line service valve.
5. Start the pump and flush the line for approximately 10 minutes and then turn the pump off.
6. Disconnect the bypass solenoid valve plug (P8) from the receptacle (J8).
7. Energize the solenoid valve by applying 28 volts dc across pins A and B of the plug (P8).
8. Start the pump and flush the line for approximately 10 minutes and then turn the pump off.
9. Switch the pump lines so that the discharge line is connected to the suction line service valve at point 3 and the recovery line is connected to the tubing at point 1.
10. Start the pump and flush the line for approximately 10 minutes and turn the pump off.

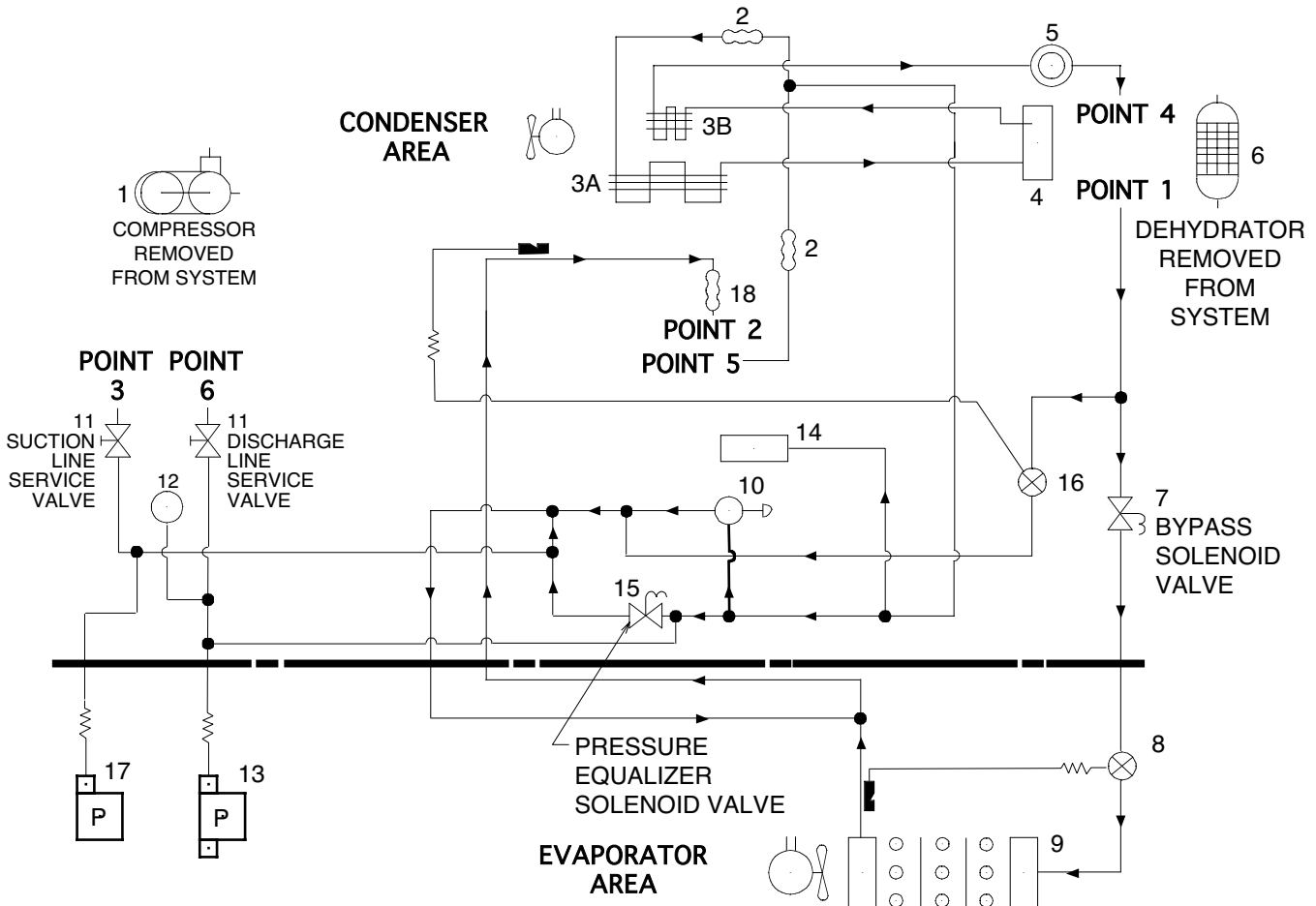

FIND NO.	QTY	NOMENCLATURE
1	1	COMPRESSOR, RECIPROCATING
2	2	HOSE ASSEMBLY, METAL
3A	1	COIL, CONDENSER WITH ANGLE
3B	1	SUB COOLER
4	1	RECEIVER, LIQUID REFRIGERANT
5	1	INDICATOR, SIGHT, LIQUID
6	1	DEHYDRATOR, DESICCANT, REFRIGERANT
7	1	SOLENOID VALVE WITH LEADS
8	1	VALVE, EXPANSION (PRIMARY)
9	1	COIL, EVAPORATOR
10	1	REGULATOR, FLUID PRESSURE
11	2	VALVE, SERVICE
12	1	VALVE, PRESSURE RELIEF
13	1	SWITCH, PRESSURE (HIGH)
14	1	CYLINDER ASSEMBLY, ACTUATING, LINEAR
15	1	SOLENOID VALVE WITH LEADS
16	1	VALVE, EXPANSION (QUENCH)
17	1	SWITCH, PRESSURE (LOW)
18	1	HOSE ASSEMBLY, METAL

11. Close the suction line service valve and move the discharge line from the valve at point 3 to the tubing at point 2.
12. Start the pump and flush the line for approximately 10 minutes and then turn the pump off.
13. De-energize the bypass solenoid valve by disconnecting the dc voltage source from pins A and B of plug P8.
14. Start the pump and flush the line for approximately 10 minutes and then turn the pump off.

Flushing - Continued

15. Uncap the tubing at points 4 and 5.
16. Disconnect the pump discharge line from the tubing at point 2 and connect it to the tubing at point 5.
17. Disconnect the recovery line from the tubing at point 1 and connect it to the tubing at point 4.
18. Cap the tubing at points 1 and 2.
19. Start the pump and flush the line for approximately 10 minutes and then turn the pump off.
20. Move the pump discharge line from the tubing at point 5 to the valve at point 6. Cap the tubing at point 5.
21. Open the discharge line service valve (point 6).
22. Start the pump and flush the line for approximately 10 minutes and then turn the pump off.
23. Switch the pump lines so that the discharge line is connected to the tubing at point 4 and the recovery line is connected to the valve at point 6.
24. Start the pump and flush the line for approximately 10 minutes and then turn the pump off.
25. Remove the cap from the tubing at point 2. Disconnect the pump discharge line from the tubing at point 4 and connect it to the tubing at point 2. Cap the tubing at point 4.
26. Disconnect the pressure equalizer solenoid valve plug (P9) from the receptacle (J9).
27. Energize the pressure equalizer solenoid valve by applying 28 volts dc across pins A and B of plug (P9).
28. Start the pump and flush the line for approximately 10 minutes and then turn the pump off.
29. Remove the cap from the tubing at point 5.
30. Remove the pump discharge line from the tubing at point 2 and connect to the tubing at point 5.
31. Remove the recovery line from the valve at point 6 and connect it to the tubing at point 2. Close the valve at point 6.
32. Start the pump and flush the line for approximately 10 minutes and then turn the pump off.
33. De-energize the pressure equalizer solenoid valve by removing the voltage source from pins A and B of plug (P9).
34. Disconnect the discharge and recovery lines from the tubing and remove all caps from the tubing.

PURGING

1. Make sure all caps are off the tubing ends and that the suction and discharge line service valves are open.
2. Connect the nitrogen line to the tubing at point 1 and release nitrogen into the system for approximately 5 minutes or until moisture ceases to be discharged from the system.
3. Energize the bypass solenoid valve by applying 28 volts dc across pins A and B of plug (P8).
4. Release nitrogen into the system for approximately 5 minutes or until moisture ceases to be discharged from the system.
5. Remove the nitrogen line from the tubing at point 1 and connect it to the tubing at point 2. Release nitrogen into the system for approximately 5 minutes or until no moisture is discharged from the system.
6. De-energize the bypass solenoid valve and release nitrogen into the system for approximately 5 minutes or until moisture ceases to be discharged from the system.
7. Energize the pressure equalizer solenoid valve by applying 28 volts dc across pins A and B of plug P9.
8. Release nitrogen into the system for approximately 5 minutes or until moisture ceases to be discharged from the system.
9. Remove the nitrogen line from the tubing at point 2 and connect it to the tubing at point 5. Release nitrogen into the system for approximately 5 minutes or until moisture ceases to be discharged from the system.
10. De-energize the pressure equalizer solenoid valve and release nitrogen into the system for approximately 5 minutes or until moisture ceases to be discharged from the system.

Purging - Continued

11. Remove the nitrogen line from the tubing at point 5 and connect it to the tubing at point 4. Release nitrogen into the system for approximately 5 minutes or until moisture ceases to be discharged from the system.
12. Remove the nitrogen line from the tubing at point 4 and connect it to the valve at point 6. Release nitrogen into the system for approximately 5 minutes or until moisture ceases to be discharged from the system.
13. Remove the nitrogen line from the valve at point 6 and connect it to the valve at point 3. Release nitrogen into the system for approximately 5 minutes or until moisture ceases to be discharged from the system.
14. Remove the nitrogen line from the valve at point 3.
15. Close the suction line and the discharge line service valves.
16. Cap all open tubing until the installation of new components.
17. Reconnect plugs P8 and P9 to receptacles J8 and J9 respectively.

NOTE

FOLLOW-ON MAINTENANCE:
Install compressor (WP 0030 00)

END OF WORK PACKAGE

DIRECT SUPPORT MAINTENANCE
AIR CONDITIONER, HORIZONTAL, COMPACT
(NSN 4120-01-502-1319)
LEAK TESTING

INITIAL SETUP:**Tools**

Refrigeration Unit Service Tool Kit (WP 0092 00, Item 1)
Goggles (WP 0092 00, Item 2)
Gloves (WP 0092 00, Item 2)
Nitrogen Regulator (WP 0092 00, Item 6)

Materials/Parts

Nitrogen (WP 0094 00, Item 8)
Refrigerant R-22 (WP 0094 00, Item 4)

Equipment Condition

Remove Top Panels (WP 0016 00)
Remove service manifold (WP 0059 00)

WARNING

Never pressurizes lines with oxygen, mixture with oil will cause an explosion.

The pressure in a nitrogen cylinder can exceed 2000 psi. A nitrogen pressure regulator should be used at all times to avoid personal injury.

Nitrogen is an inert gas that can cause suffocation and must be discharged in a well-ventilated area.

NOTE

Test for leaks with either a refrigerant gas leak detector or a strong solution of liquid detergent in water.

If an electronic refrigerant gas leak detector is available, it should be used in accordance with the procedures contained in TM 9-4940-435-14, Leak Detector, Refrigerant Gas. Unit contains R-22, a chemical substance that harms public health and the environment by destroying ozone in the upper atmosphere. Qualified personnel must service equipment only.

To perform leak testing by use of the electronic detector, it is necessary that the system be pressurized with a proportion of refrigerant gas. To perform leak testing by use of the soap solution method, the system may be pressurized with dry nitrogen alone.

A. To pressurize a system that has some refrigerant charge:

- 1) Connect the 1/4 inch yellow hose (charge) to a Refrigerant-22 (R-22) cylinder.
- 2) Open the service manifold compound gauge, pressure gauge, and the charge valves.
- 3) Check that the service manifold vacuum valve is closed.
- 4) Open the refrigerant cylinder valve and pressurize the system to 100 psi (7.1 kg/cm²).
- 5) Test for leaks at all points of possible leaks by using an electronic refrigerant gas leak detector or by brushing on a soap solution while closely observing for bubbles to form.

- 6) If a leak is detected, discharge and purge the system and repair the leak. Retest for leaks.
 - 7) If a soap solution was used to test for leaks, thoroughly rinse test areas with fresh water.
 - 8) If no leaks were found, check the unit charge (WP 0066 00) and (WP 0069 00).
- B. To pressurize a system that has been discharged and purged:
- 1) Connect the 1/4 inch yellow hose (charge) to a cylinder of refrigerant R-22 set to deliver gas only.
 - 2) Open the service manifold compound gauge, pressure gauge, and charge valves.
 - 3) Check that the service manifold vacuum valve is closed.
 - 4) Open the refrigerant cylinder valve and pressurize the system to 40-50 psi (2.8-3.5 kg/cm²).
 - 5) Close the service manifold valves and the refrigerant cylinder valve.
 - 6) Disconnect the 1/4 inch yellow hose (charge) from the refrigerant cylinder..
 - 7) Connect the 1/4 inch yellow hose (charge) to a nitrogen regulator and dry nitrogen cylinder.
 - 8) Open the service manifold compound gauge, pressure gauge, and charge valves.
 - 9) Open the nitrogen cylinder valve and pressurize the system to 350 psi (24.7 kg/cm²).
 - 10) Close the service manifold valves and nitrogen cylinder valve.
 - 11) Test for leaks at all points of possible leaks by using an electronic refrigerant gas leak detector or by brushing on a soap solution while closely observing for bubbles to form.
 - 12) If a leak is detected, discharge and purge the system and repair the leak. Retest for leaks
 - 13) If a soap solution was used to test for leaks, thoroughly rinse test areas with fresh water.
 - 14) After performing the leak tests, discharge and purge the system before performing maintenance or evacuating and charging the system, as appropriate (WP 0060 00) and (WP 0061 00).

NOTE

FOLLOW-ON MAINTENANCE:
Install service manifold (WP 0059 00)
Install top panel (WP 0016 00)

END OF WORK PACKAGE

DIRECT SUPPORT MAINTENANCE
AIR CONDITIONER, HORIZONTAL, COMPACT
(NSN 4120-01-502-1319)
EVACUATING THE REFRIGERATION SYSTEM

INITIAL SETUP:**Tools**

Refrigeration Unit Service Tool Kit (WP 0092 00, Item 1)
 Vacuum Pump WP 0092 00, Item 2)

Materials/Parts

Nitrogen (WP 0094 00, Item 8)
 Refrigerant R-22 (WP 0094 00, Item 4)

Equipment Condition

Install service manifold (WP 0059 00)

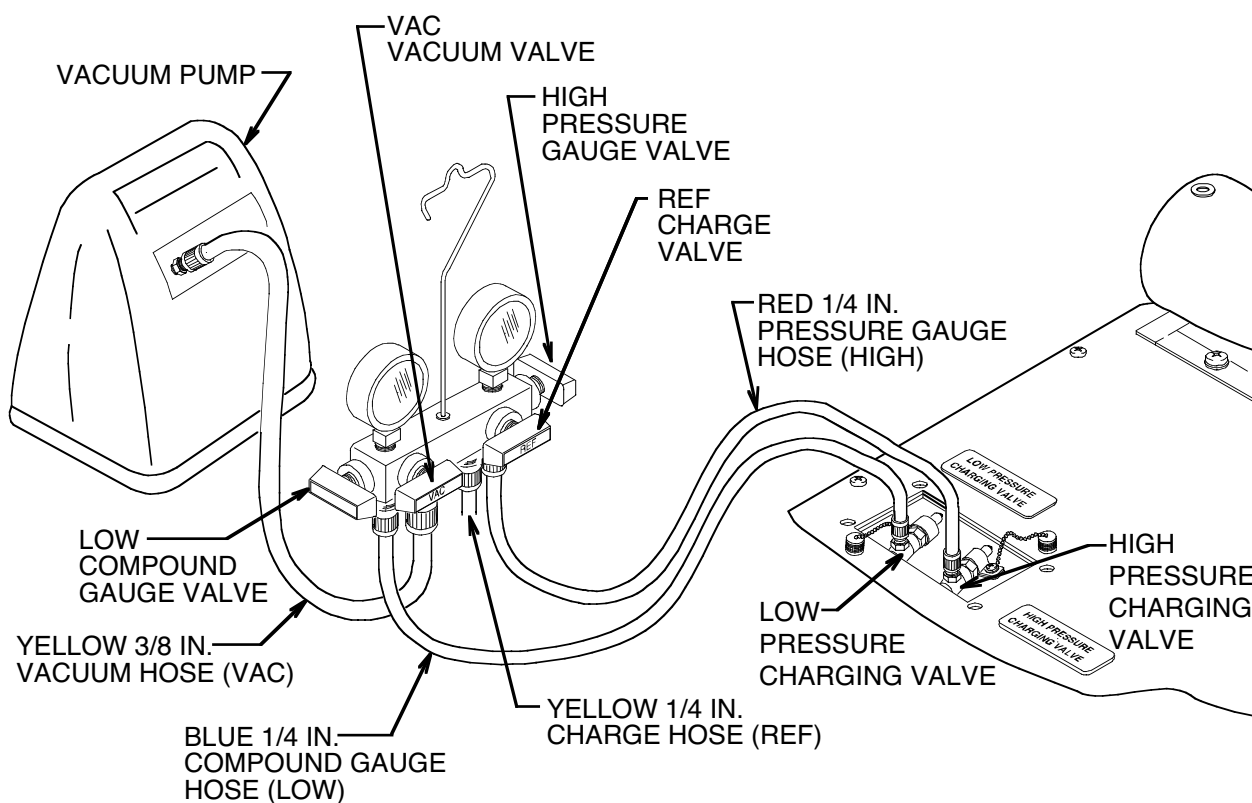
**EVACUATION**

1. Check that the new dehydrator was installed. If not, install one. (WP 0070 00).
2. Check that the service manifold charge valve is closed.
3. Check that the unit HIGH and LOW pressure charging valves are open.
4. Connect the 3/8-inch hose to the vacuum pump.
5. Start the vacuum pump.
6. Open the service manifold high pressure gauge, compound gauge, and vacuum valves.
7. Run the vacuum pump until at least 29 inches of mercury is measured on the compound gauge.

NOTE

Inability to reach and hold 29 inches of mercury may indicate either a leak or a problem with the vacuum pump.

8. Continue running the vacuum pump for one more hour while observing the gauge.
9. Close the unit HIGH and LOW pressure charging valves.
10. Close the service manifold high pressure gauge, compound gauge, and vacuum valves.
11. Stop the vacuum pump.
12. Disconnect the 3/8-inch yellow hose from the vacuum pump.

NOTE

FOLLOW-ON MAINTENANCE:
Charge the refrigerant system (WP 0066 00)

END OF WORK PACKAGE

DIRECT SUPPORT MAINTENANCE
AIR CONDITIONER, HORIZONTAL, COMPACT
(NSN 4120-01-502-1319)
CHARGING THE REFRIGERATION SYSTEM

INITIAL SETUP:**Tools**

Refrigeration Unit Service Tool Kit (WP 0092 00, Item 1)
 Goggles (WP 0092 00, Item 2)
 Gloves (WP 0092 00, Item 2)

Materials/Parts

Refrigerant R-22 (WP 0094 00, Item 4)

Equipment Condition

Evacuate the refrigerant system (WP 0065 00)
 Remove Service Manifold (WP 0059 00)

WARNING

Dangerous Chemical Refrigerant Under Pressure is used in the operation of this equipment.

Use great care to avoid contact with the liquid refrigerant or inhaling refrigerant gas that is discharged from any container that is pressurized. Sudden and irreversible tissue damage can result from freezing. Wear thermal protective gloves and a face protector or safety glasses in any situation when skin or eye contact is possible.

Prevent contact of refrigerant gas with a flame or other hot surfaces. Heat causes the refrigerant to break down and form carbonyl chloride (phosgene), a highly toxic and corrosive gas. Unit contains R-22, a chemical substance that harms public health and the environment by destroying ozone in the upper atmosphere. Qualified personnel must service equipment only.

Never introduce high discharge pressure into a refrigerant cylinder. This can cause the cylinder to rupture and injure personnel.

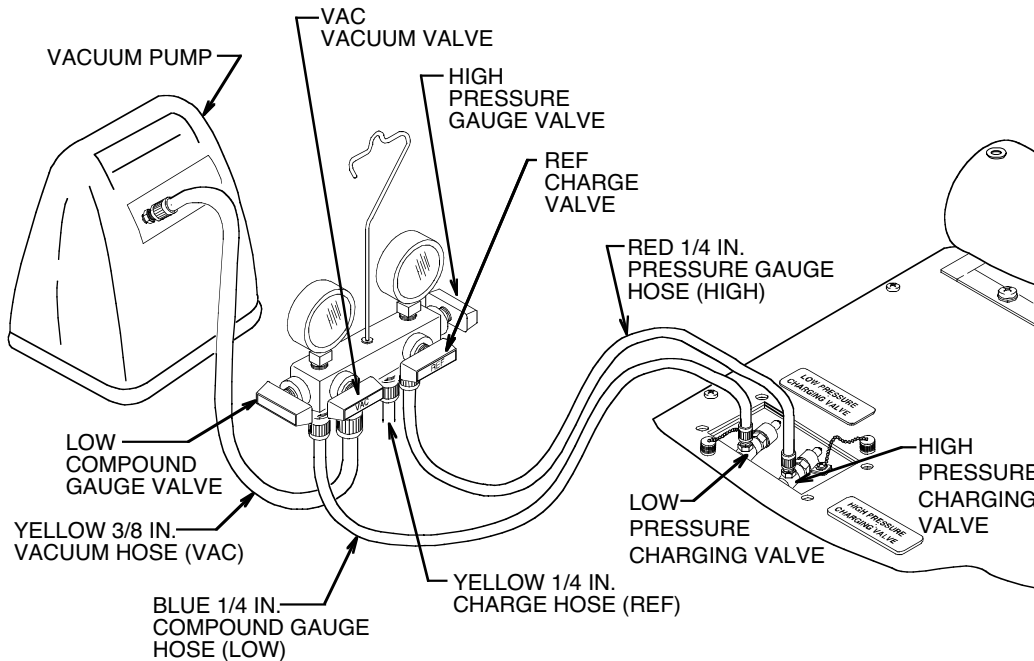

WARNING

Dangerous Chemical Pressurized Refrigerant is used during the operation of this equipment.

Use great care to avoid contact with liquid refrigerant or inhaling refrigerant gas being discharged from any container under pressure. Sudden and irreversible tissue damage can result from freezing. Wear thermal protective gloves and a face protector or safety glasses in any situation where skin or eye contact is possible.

Heat causes the refrigerant to break down and form carbonyl chloride (phosgene), a highly toxic and corrosive gas. Avoid contact between refrigerant gas and a flame or other hot surfaces.

NOTE

The charging operation should be done with all panels in place except for refrigerant charging valve access cover. Use recycled refrigerant whenever possible.

FULL CHARGE

1. Connect the 1/4 inch yellow hose (charge) to a cylinder of R-22 set to deliver gas only.
2. Slightly loosen hose connections on the HIGH and LOW pressure charging valves.
3. Ensure the vacuum and charge valves are closed.
4. Open the pressure gauge and compound gauge valves.
5. Open the refrigerant cylinder valve.
6. Slightly open the charge valve to allow a small amount of refrigerant to purge air from the hoses. Tighten all hose connections on the HIGH and LOW pressure charging valves. Close the charge valves.

CAUTION

Severe damage can affect the compressor. Never introduce liquid refrigerant into the low pressure (suction) charging valves.

7. Close the compound gauge valve.
8. Set the refrigerant cylinder to deliver liquid only.
9. Place the refrigerant cylinder on an accurate scale to measure and record weight.
10. Open the HIGH and LOW-pressure charging valves.
11. Open the charge valve. Allow liquid refrigerant to enter the system until the drum weight has decreased by 2.2 pounds (1.0 kg) or until the system pressure has equalized.
12. Close the charge and pressure gauge valves.
13. Reset the low pressure and high-pressure cutout switches.
14. Connect the power at the power source.
15. Turn the air conditioner on and operate in COOL mode with the temperature selector set at the maximum COOLER position.

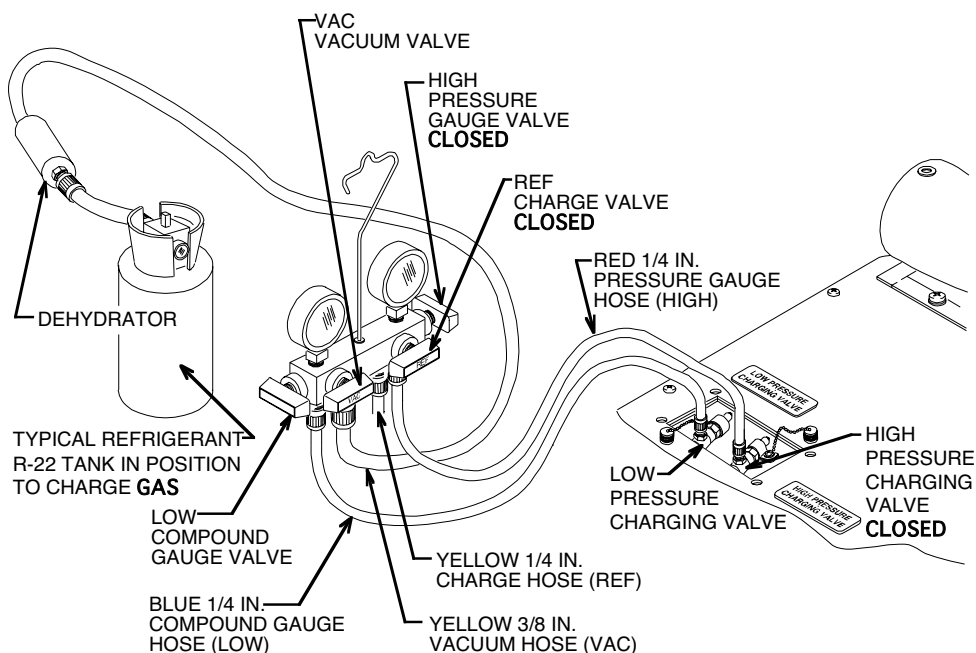

16. Set the refrigerant cylinder to deliver gas only.
17. Ensure the pressure gauge valve is closed.
18. Open the compound gauge valve.
19. Open the charge valve.
20. Monitor the weight of the refrigerant cylinder as the air conditioner compressor pulls additional refrigerant into the system until full charge is obtained (2.2 pounds (1.0 kg)).
21. Run the air conditioner in COOL mode with the temperature set at the maximum COOLER position for 15 minutes.
22. With the unit running, observe the sight glass on the back of the condenser section. Be sure that the refrigeration system is not in BYPASS mode. When the system goes into BYPASS, bubbles will appear in the sight glass.
 - A green center indicates the refrigerant moisture content is acceptable.
 - A yellow center indicates there is too much moisture in the system. It must be discharged, evacuated, and charged again.
 - A milky-white or bubbly liquid indicates the system has a low charge.
 - A clean, bubble-free liquid around the center indicates the system is fully charged.
23. If the charge is still low, carefully add refrigerant.

CAUTION

Severe damage can affect the compressor. Never introduce liquid refrigerant into the low pressure (suction) charging valves.

- a) Set the refrigerant cylinder to deliver gas only.

WARNING

The cylinder may rupture and cause personnel injury. Never introduce a high discharge pressure into a refrigerant cylinder.

- b) Ensure the pressure gauge valve is closed.
- c) Open the compound gauge and charge valves.
- d) Continue to charge until the sight glass is clear and bubble-free.

24. Turn the MODE SELECTOR switch is set to OFF.

PARTIAL CHARGE

WARNING

Dangerous Chemical Pressurized Refrigerant is used during the operation of this equipment.

Use great care to avoid contact with liquid refrigerant or inhaling refrigerant gas being discharged from any container under pressure. Sudden and irreversible tissue damage can result from freezing. Wear thermal protective gloves and a face protector or safety glasses in any situation where skin or eye contact is possible.

Prevent contact of refrigerant gas with open flames or hot surfaces. Heat causes the refrigerant to break down and form carbonyl chloride (phosgene), a highly toxic and corrosive gas.

NOTE

The charging operation should be done with all panels in place except for the refrigerant charging valve access cover. Use recycled refrigerants whenever possible.

1. Connect the 1/4 inch yellow hose (charge) to a cylinder of R-22 set to deliver gas only.
2. Slightly loosen hose connections on the HIGH and LOW pressure charging valves.
3. Ensure the vacuum and charge valves are closed.
4. Open the pressure gauge and compound gauge valves.
5. Open the refrigerant cylinder valve.
6. Slightly open the charge valve to allow a small amount of refrigerant to purge air from the hoses. Tighten all hose connections on the HIGH and LOW pressure charging valves. Close the charge valves.

CAUTION

Severe damage can affect the compressor. Never introduce liquid refrigerant into the low pressure (suction) charging valves.

7. Close the compound gauge valve.
8. Connect the power at the power source.

-
9. Turn the air conditioner on and operate in COOL mode with the temperature selector set at the maximum COOLER position.
 10. With the unit running, observe the sight glass on the back of the condenser section. Be sure that the refrigeration system is not in BYPASS mode. When the system goes into BYPASS, bubbles will appear in the sight glass.
 - A green center indicates the refrigerant moisture content is acceptable.
 - A yellow center indicates there is too much moisture in the system. It must be discharged, evacuated, and charged again.
 - A milky-white or bubbly liquid indicates the system has a low charge.
 - A clean, bubble-free liquid around the center indicates the system is fully charged.
 11. If the charge is still low, carefully add refrigerant.

CAUTION

Severe damage can affect the compressor. Never introduce liquid refrigerant into the low pressure (suction) charging valves.

12. If the charge is still low, carefully add refrigerant.

CAUTION

Severe damage can affect the compressor. Never introduce liquid refrigerant into the low pressure (suction) charging valves.

- a) Set the refrigerant cylinder to deliver gas only.

WARNING

The cylinder may rupture and cause personnel injury. Never introduce a high discharge pressure into a refrigerant cylinder.

- b) Ensure the pressure gauge valve is closed.
 - c) Open the compound gauge and charge valves.
 - d) Continue to charge until the sight glass is clear and bubble-free.
 - e) Close the compound gauge and the charge and refrigerant cylinder valve.
13. Turn the MODE SELECTOR switch is set to OFF.

NOTE

FOLLOW-ON MAINTENANCE:
Install service manifold (WP 0059 00)

END OF WORK PACKAGE

DIRECT SUPPORT MAINTENANCE
AIR CONDITIONER, HORIZONTAL, COMPACT
(NSN 4120-01-502-1319)
REFRIGERATION SYSTEM TROUBLESHOOTING

INITIAL SETUP:**Equipment Condition**

Unit operating in full COOL mode.

EXAMINATION

1. Check the sight glass condition.
 - a) A bright green color indicates that the refrigerant is dry. As moisture content increases, the color will gradually change from chartreuse until it reaches pure yellow. On average, a gradual change from green to chartreuse over an extended period of time is an indication that the dehydrator is becoming saturated with moisture. A sudden change of color is highly unlikely, unless a rupture occurs, allowing the refrigerant to escape. Correct as indicated.

NOTE

Numerous bubbles will appear when the system goes into bypass. This is normal. Be sure that the refrigeration system is under full load when observing the sight glass for refrigerant condition.

- b) The experience of an occasional bubble in the sight glass can be expected, especially when operating in a high ambient temperature. A gradual increase in the number and frequency of bubbles is usually an indication that the refrigerant charge is lost from the system through a small leak. The number and frequency of bubbles will also increase if the refrigeration system becomes overheated. The sudden appearance of numerous bubbles is usually an indication of a serious leak. Correct as indicated.
2. Check for decreased cooling capacity.

A reduction in cooling capacity will occur as a natural result if the refrigerant escapes from the system. This will result in a total loss of cooling if all refrigerant is lost. In some conditions, however, a considerable portion of the refrigerant may be lost before the reduced cooling capacity is noticeable. Sudden reduction or complete loss of cooling capacity is often caused by the malfunction of one of the valves in the refrigeration system. Cooling capacity will also be reduced if the refrigeration system becomes overheated. Correct as indicated.

NOTE

FOLLOW-ON MAINTENANCE:
Turn unit OFF

END OF WORK PACKAGE

DIRECT SUPPORT MAINTENANCE
AIR CONDITIONER, HORIZONTAL, COMPACT
(NSN 4120-01-502-1319)
OVERHEATING CHECKS

INITIAL SETUP:

Equipment Condition

Unit operating in full COOL mode.

EXAMINATION

NOTE

Bubbles appearing in the sight glass OR a reduction in the cooling capacity is often caused by an overheated refrigeration system. Adequate cooling of the hot, compressed refrigerant vapor in the condenser is essential to the proper operation of the air conditioner.

Painting coils will cause overheating, thereby reducing the cooling capacity.

The following checks should be made to ensure that overheating is not the cause of the symptoms prior to troubleshooting the pressurized portion of the refrigeration system.

- a) Be sure there is no external obstruction to the airflow into the condenser intake screen and out of the condenser fan guard.
- b) Be sure there is no obstruction within the intake screen and fan guard.
- c) Be sure there are no obstructions or an excessive build-up of dust or dirt in the condenser coil.

NOTE

FOLLOW-ON MAINTENANCE:

Turn the unit OFF

END OF WORK PACKAGE

DIRECT SUPPORT MAINTENANCE
AIR CONDITIONER, HORIZONTAL, COMPACT
(NSN 4120-01-502-1319)
REFRIGERANT PRESSURE CHECK

INITIAL SETUP:**Tools**

N/A

Goggles (WP 0092 00, Item 2)

Gloves (WP 0092 00, Item 2)

Materials/Parts

Refrigeration Unit Service Tool Kit (WP 0092 00, Item 1)

Equipment Condition

Remove service manifold (WP 0059 00)

TESTING

1. Check that the unit HIGH and LOW pressure charging valves are open and all four service manifold valves are closed.
2. Both gages should read the same. Check the reading with the appropriate column in Table 1. If the system is partially charged, the pressure should be approximately equal to that shown in the table for the appropriate ambient temperature. If the pressure is considerable less than the reading shown in Table 1, the system does not contain enough refrigerant to continue the pressure check; proceed directly to leak testing (See WP 0067 00).
3. Turn the air conditioner on and operate in COOL mode with the TEMPERATURE SELECTOR at the fullest cooler setting for five minutes.
4. Allow gages to stabilize and take readings of the two gages.

If the discharge and suction pressures are at (or near) the same value, a pressure equalizer solenoid valve L2 or compressor failure is indicated.

- a) If discharge pressure is low and suction pressure is normal, a low refrigerant is indicated (Table 2).
 - b) If discharge pressure is normal and the suction pressure is either high or low, failure or maladjustment of the pressure regulator valve is indicated (Table 2).
 - c) If ice forms on the evaporator coil, or evaporator coil does not cool during operation, failure or malfunction of the evaporator expansion valve is indicated.
 - d) If the discharge pressure is high and suction pressure is normal, a malfunction of the quench valve is indicated.
 - e) If the discharge pressure is above 540 psi, the pressure relief valve malfunction is also indicated.
5. When pressure tests are completed, turn the unit off and proceed with any maintenance action indicated.

Table 1. Pressure/Temperature Relationship of Saturated Refrigerant.

TEMPERATURE		PRESSURE		TEMPERATURE		PRESSURE	
DEG F	DEG C	PSIG	KG/CM2	DEG F	DEG C	PSIG	KG/CM2
10	-12.3	32.93	2.315	66	18.9	114.2	8.029
12	-11.1	34.68	2.439	68	20.0	118.3	8.318
14	-10.0	36.89	2.593				
16	-8.9	38.96	2.739	70	21.1	122.5	8.612
18	-7.8	41.09	2.889	72	22.2	126.8	8.915
				74	23.3	131.2	9.225
20	-6.6	43.28	3.043	76	24.4	135.7	9.541
22	-5.5	45.23	3.180	78	25.6	140.3	9.864
24	-4.3	47.85	3.364				
26	-3.4	50.24	3.532	80	26.7	145.0	10.195
28	-2.2	52.70	3.705	82	27.8	149.8	10.522
				84	28.9	154.7	10.877
30	-1.1	55.23	3.883	86	30.0	159.8	11.236
32	0	57.83	4.066	88	31.1	164.9	11.594
34	1.1	60.51	4.254				
36	2.2	63.27	4.448	90	32.2	170.1	11.960
38	3.3	66.11	4.648	92	33.3	175.4	12.332
				94	34.5	180.9	12.719
40	4.4	69.02	4.853	96	35.6	186.5	13.113
42	5.5	71.99	5.062	98	36.7	192.1	13.506
44	6.6	75.04	5.276				
46	7.7	78.18	5.497	100	37.8	197.9	13.914
48	8.8	81.40	5.723	102	38.9	203.8	14.329
				104	40.0	209.9	14.758
50	10.0	84.70	5.955	106	41.1	216.0	15.187
52	11.1	88.10	6.257	108	42.2	222.3	15.630
54	12.2	91.5	6.433				
56	13.3	95.1	6.686	110	43.3	228.7	16.080
58	14.5	98.8	6.947	112	44.4	235.2	16.537
				114	45.6	241.9	17.008
60	15.6	102.5	7.206	116	46.7	248.7	17.486
62	16.7	106.3	7.474	118	47.8	255.6	17.971
64	17.8	110.2	7.748				

Table 2. Normal Operating Pressures

TEMPERATURES	PRESSURE RANGE (PSIG)			
Outdoor Ambient	55 degrees F (12.8 C)	75 degrees F (24 C)	100 degrees F (38 C)	125 degrees F (51.7 C)
90 degrees F 32 C Return Air to Unit (Dry Bulb)	60-70 Suction 205-220 Discharge	62-72 Suction 225-245 Discharge	70-80 Suction 305-325 Discharge	80-95 Suction 400-425 Discharge
80 degrees F (27 C) Return Air to Unit Dry Bulb	60-70 Suction 185-205 Discharge	60-70 Suction 215-235 Discharge	65-75 Suction 290-310 Discharge	70-80 Suction 385-415 Discharge

NOTE

FOLLOW-ON MAINTENANCE:
Install service manifold (WP 0059 00)

END OF WORK PACKAGE

DIRECT SUPPORT MAINTENANCE
AIR CONDITIONER, HORIZONTAL, COMPACT
(NSN 4120-01-502-1319)
DEHYDRATOR (FILTER/DRIER) REPLACEMENT

INITIAL SETUP:**Tools**

Refrigeration Unit Service Tool Kit (WP 0092 00, Item 1)

Materials/Parts

Dehydrator

Equipment Condition

Remove top, rear panel (WP 0016 00)
 Discharge refrigerant system (WP 0060 00)

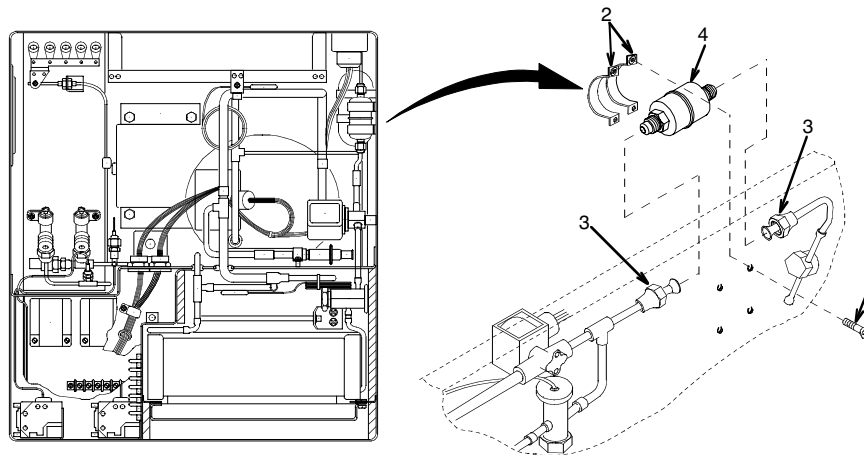
**REPLACEMENT**

1. Remove four screws (1) and two mounting clamps (2).
2. Disconnect two flare nuts (3) and remove the dehydrator (4) from the unit.

CAUTION

Replacement dehydrators are packaged with sealing caps on the flare fittings to prevent moisture contamination of the desiccant filtering media. Remove these caps immediately prior to installation. Never install a dehydrator from which caps have been removed for an extended or unknown period of time.

3. Connect two flare nuts (3) to each end of the dehydrator (4).
4. Install the mounting clamps (2) with two screws (1).

NOTE

FOLLOW-ON MAINTENANCE:
 Leak test refrigerant system (WP 0064 00)
 Evacuate refrigerant system (WP 0065 00)
 Charge refrigerant system (WP 0066 00)
 Install top, rear panel (WP 0016 00)

END OF WORK PACKAGE

DIRECT SUPPORT MAINTENANCE
AIR CONDITIONER, HORIZONTAL, COMPACT
(NSN 4120-01-502-1319)
EVAPORATOR COIL REPLACEMENT

INITIAL SETUP:**Tools**

Refrigeration Unit Service Tool Kit (WP 0092 00, Item 1)
 Gloves (WP 0092 00, Item 2)

Equipment Condition

Remove top, panel (WP 0016 00)
 Remove supply air louver (WP 0019 00)
 Remove mist eliminator (WP 0021 00)
 Remove dehydrator (WP 0070 00)
 Purge refrigerant system (WP 0061 00)

Materials/Parts

Evaporator Coil

WARNING

When handling coils, wear gloves to avoid cuts and reduce fin damage on the coil.

REPLACEMENT

1. Remove two screws (1) that secure the solenoid valve (2).
2. De-braze the tube connections at the elbow (3) and expansion valve (4) (WP 0065 00). Take care that the expansion valve is not damaged during de-brazing operations.
3. Remove two flat head screws (5) from the top that attach the coil (6) to the housing. Remove two flat head screws (7) from the side and two screws (8), lock washers (9), and flat washers (10) that attach the mist eliminator holder (11) and coil (6) to the housing.
4. Lift the mist eliminator holder (11) up and out of the unit.
5. Lift the evaporator coil (6) up and out of the unit.
6. Carefully position the evaporator coil (6) in the unit.
7. Position the mist eliminator holder (11) in the unit.
8. Secure the mist eliminator holder and the evaporator coil (6) to the housing with four flat head screws (5 and 7). Secure the evaporator coil to the housing with two screws (8), lock washers (9), and flat washers (10) each. The four holes in the mist eliminator holder should match the bottom four holes in the coil.
9. Align the tubing connections to the elbow (3) and expansion valve (4). Braze the joints (WP 0062 00). Take care that the expansion valve is protected during the brazing operation.
10. Secure the solenoid valve (2) with two screws (1)

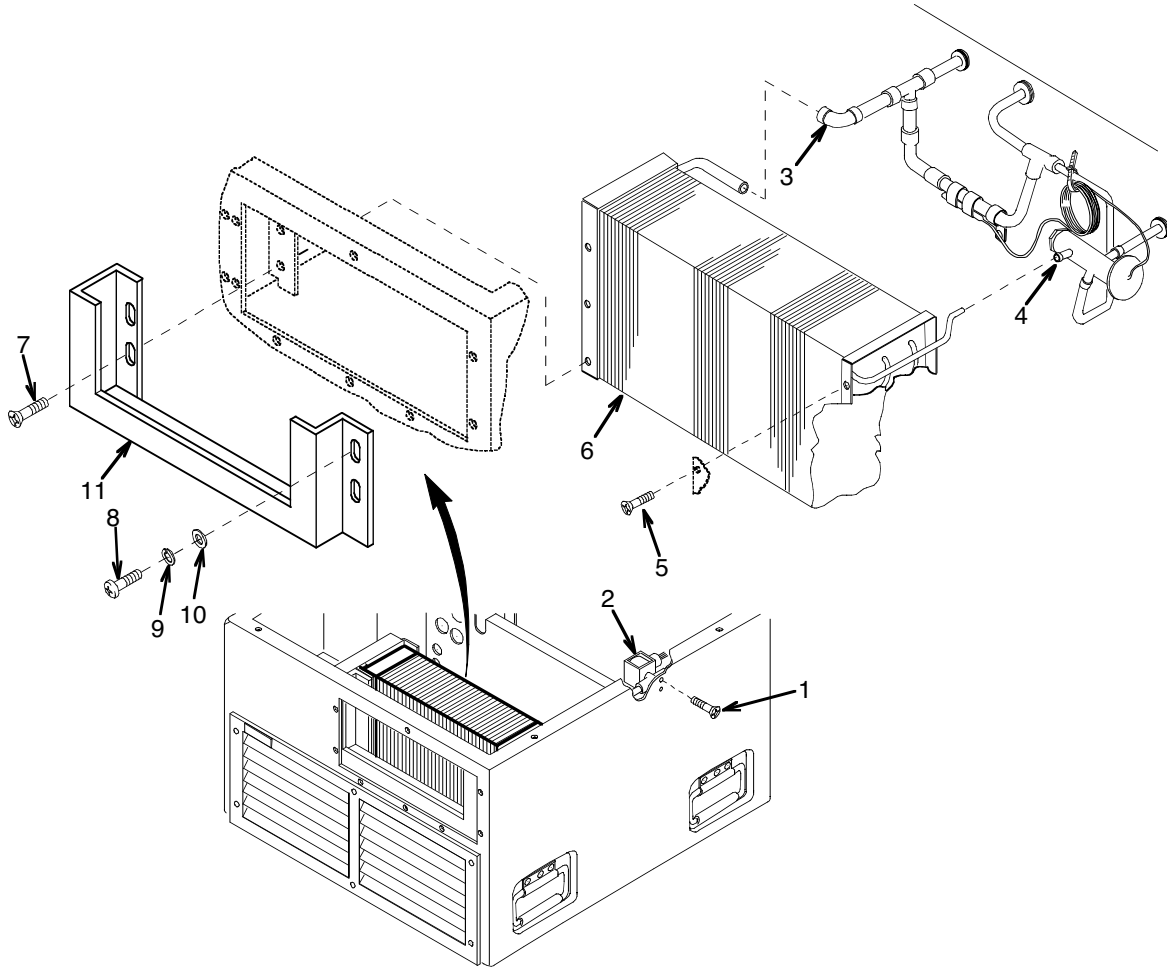

NOTE

FOLLOW-ON MAINTENANCE:
 Install new dehydrator (WP 0070 00)
 Install mist eliminator (WP 0021 00)
 Install supply air louver (WP 0019 00)
 Install top panels (WP 0016 00)

END OF WORK PACKAGE

DIRECT SUPPORT MAINTENANCE
AIR CONDITIONER, HORIZONTAL, COMPACT
(NSN 4120-01-502-1319)
EXPANSION VALVE (PRIMARY) REPLACEMENT

INITIAL SETUP:**Tools**

Refrigeration Unit Service Tool Kit(WP 0092 00, Item
1)

Equipment Condition

Remove top panel (WP 0016 00)
Remove dehydrator (WP 0070 00)
Purge refrigerant system (WP 0061 00)

Materials/Parts

Expansion Valve
Tie Down Straps
Insulation Tape (WP 0094 00, Item 18)

REPLACEMENT

1. Unwrap insulation from the thermal bulb (1).
2. Loosen all hardware in the thermal bulb clamps (2) and slip the bulb (1) out of the clamps.
3. Cut the plastic tie-down strap (3) holding capillary tubing coil to the tubing.
4. De-braze three tube connections (4) to the valve (WP 0062 00).
5. Remove the valve (5) from the unit.
6. Place the expansion valve (5) in the unit and align the tubing ends (4).
7. Braze the joints (WP 0062 00).
8. Install the thermal bulb (1) in the clamps (2) and tighten the hardware.
9. Rewrap insulation at the thermal bulb (1).
10. Carefully coil the capillary tubing and secure with a plastic tie-down strap.

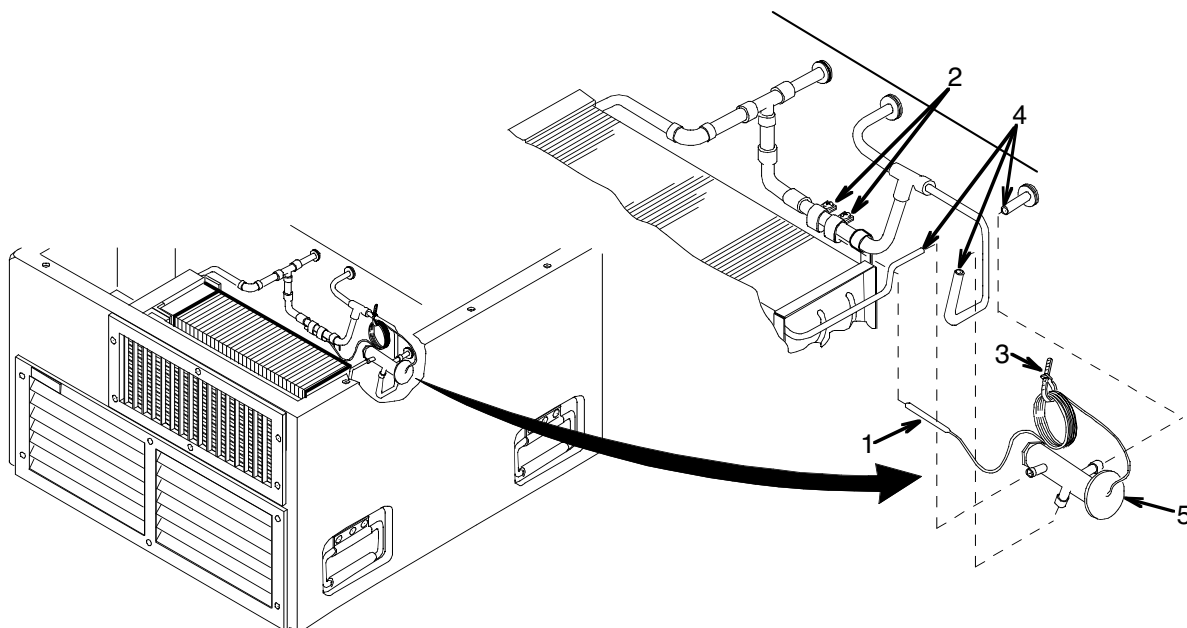
**NOTE**

FOLLOW-ON MAINTENANCE:
Install new dehydrator (WP 0070 00)
Install top front panel (WP 0016 00)

END OF WORK PACKAGE

DIRECT SUPPORT MAINTENANCE
AIR CONDITIONER, HORIZONTAL, COMPACT
(NSN 4120-01-502-1319)
EXPANSION VALVE (QUENCH)

INITIAL SETUP:**Tools**

Refrigeration Unit Service Tool Kit (WP 0092 00, Item 1)

Insulation Tape (WP 0094 00, Item 18)
Flush Bushing
Self-locking nuts (2)

Equipment Condition

Remove top panel (WP 0016 00)
Remove dehydrator (WP 0070 00)
Purge refrigerant system (WP 0061 00)

Materials/Parts

Expansion Valve
Tie Down Straps

REPLACEMENT

1. Unwrap the insulation from the thermal bulb (1)
2. Loosen all hardware in the clamps (2) that hold the thermal bulb (1) in place and slip the thermal bulb out of clamps.
3. Cut the plastic tie-down strap (3) from the capillary line.
4. De-braze two tube connections (4) to the valve (5).
5. Remove two screws (6), post spacers (7), brackets (8), and self-locking nuts (9).
6. Remove the valve (5) from the unit.
7. Install the flush bushing (10) in the valve (5).
8. Place the expansion valve (5) in the unit and align the tubing ends (4).
9. Braze the joints (WP 0062 00).
10. Secure the valve (5) to the housing with two screws (6), post spacers (7), brackets (8), and lock nuts (9) each.
11. Install the sensing bulb (1) into the clamps and tighten the screw and nut.
12. Re-wrap the insulation at the sensing bulb.
13. Coil any excess capillary line of the expansion valve (5) and secure with tie-down straps (3).

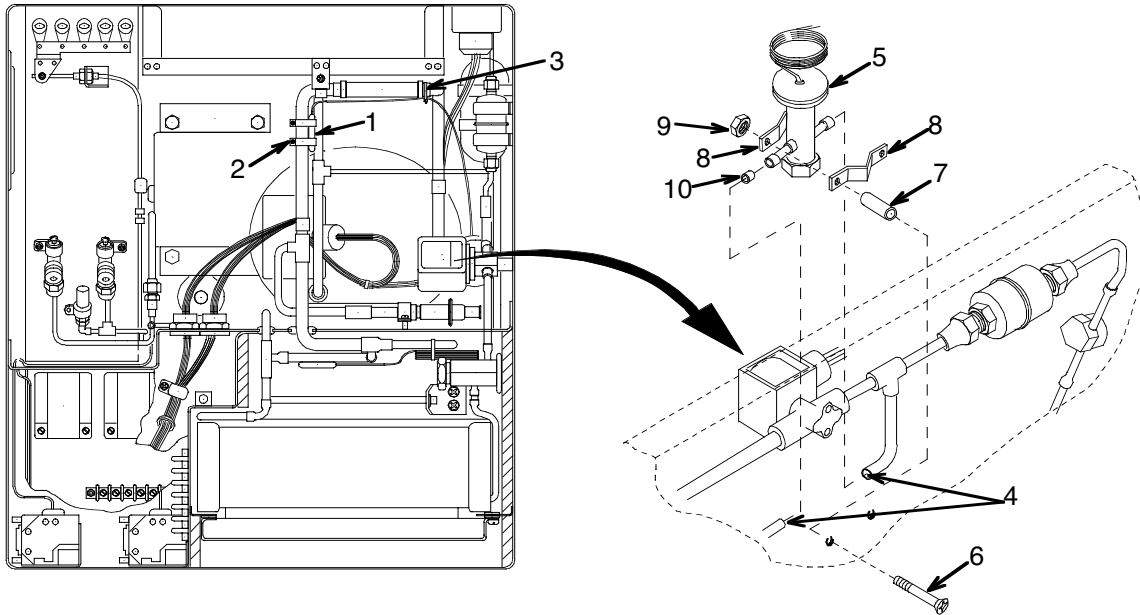

NOTE

FOLLOW-ON MAINTENANCE:
Install new dehydrator (WP 0070 00)
Install top panels (WP 0016 00)

END OF WORK PACKAGE

DIRECT SUPPORT MAINTENANCE
AIR CONDITIONER, HORIZONTAL, COMPACT
(NSN 4120-01-502-1319)
SOLENOID VALVE L1 REPLACEMENT

INITIAL SETUP:**Tools**

Refrigeration Unit Service Tool Kit (WP 0092 00, Item
1)

Equipment Condition

Remove top panel (WP 0016 00)
Remove dehydrator (WP 0070 00)
Purge refrigerant system (WP 0061 00)

Materials/Parts

Solenoid Valve
Flush Bushings

REPLACEMENT

1. Remove the top nut (1), data plate (2), and coil (3) from the tube and plunger assembly (4). Carefully lay the coil (3) aside.
2. Remove two screws (5), tube and plunger assembly (4), O-Ring (6), and diaphragm (7) from the valve body (8).
3. Remove two screws (9) and spacers (10) that attach the valve body (8) to the housing.
4. De-braze the joints and remove the valve body (8).
5. Remove two screws (5), tube and plunger assembly (4), O-Ring (6), and diaphragm (7) from the new valve body (8).
6. Install the flush bearings (11) in the valve body (8).
7. Braze the tubing to the valve body (8) (See WP 0062 00).
8. Secure the valve body (8) to the housing with two screws (9) and spacers (10).
9. Install the O-Ring (6), diaphragm (7), and tube and plunger assembly (4). Secure to the valve body (8) with two screws (5).
10. Install the coil (3) and data plate (2), with the attaching nut (1) on the tube and plunger assembly (4).

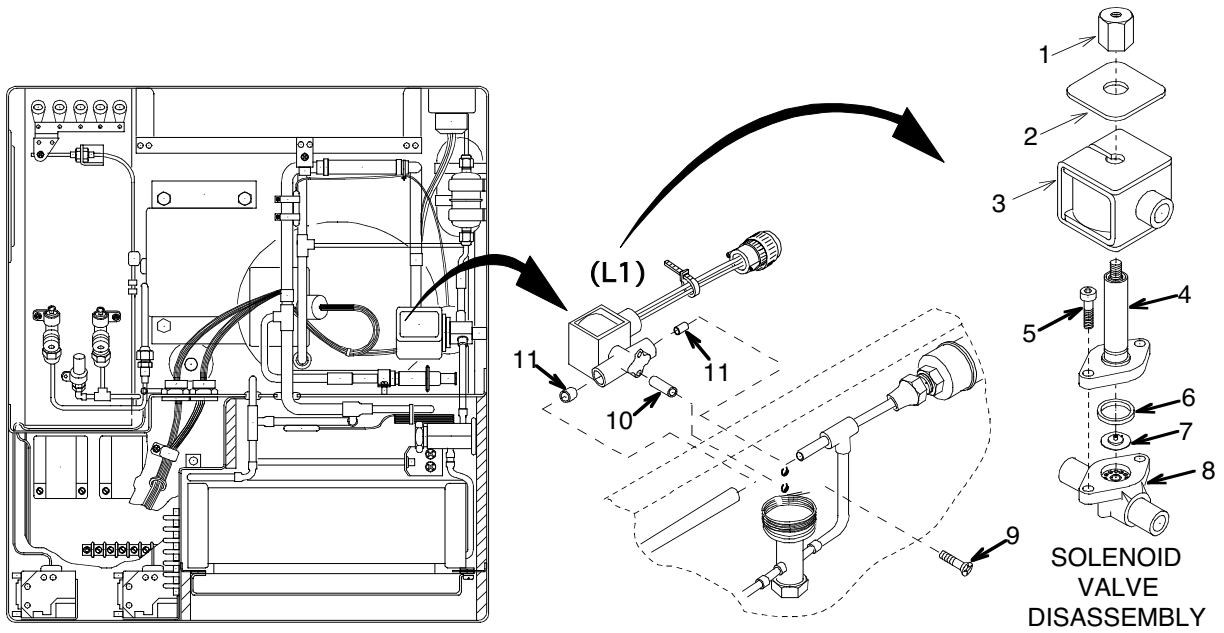

NOTE

FOLLOW-ON MAINTENANCE:
 Install new dehydrator (WP 0070 00)
 Install top panel (WP 0016 00)

END OF WORK PACKAGE

DIRECT SUPPORT MAINTENANCE
AIR CONDITIONER, HORIZONTAL, COMPACT
(NSN 4120-01-502-1319)
SOLENOID VALVE L2 REPLACEMENT

INITIAL SETUP:**Tools**

Refrigeration Unit Service Tool Kit (WP 0092 00, Item
1)

Equipment Condition

Remove top panel (WP 0016 00)
Remove condenser fan motor (WP 0047 00)
Remove dehydrator (WP 0070 00)
Purge refrigerant system (WP 0061 00)

Materials/Parts

Solenoid Valve
Flush Bushings (2)
Lock Washers (2)

REPLACEMENT

1. Remove the top nut (1), data plate (2), and coil (3) from the tube and plunger assembly (4). Carefully lay the coil (3) aside.
2. Remove two screws (5), tube and plunger assembly (4), O-Ring (6), and diaphragm (7) from the valve body (8).
3. Remove two screws (9) and spacers (10) that attach the valve body (8) to the bracket (11).
4. De-braze the joints and remove the valve body (8). (See WP 0065 00).
5. Remove two screws (5), tube and plunger assembly (4), O-Ring (6), and diaphragm (7) from the new valve body (8).
6. Install the flush bearings (11) in the valve body (8).
7. Braze the tubing to the valve body (8) (See WP 0062 00).
8. Secure the valve body (8) to the bracket (11) with two screws (9) and spacers (10).
9. Install the O-Ring (6), diaphragm (7), and tube and plunger assembly (4). Secure to the valve body (8) with two screws (5).
10. Install the coil (3) and data plate (2), with the attaching nut (1) on the tube and plunger assembly (4).

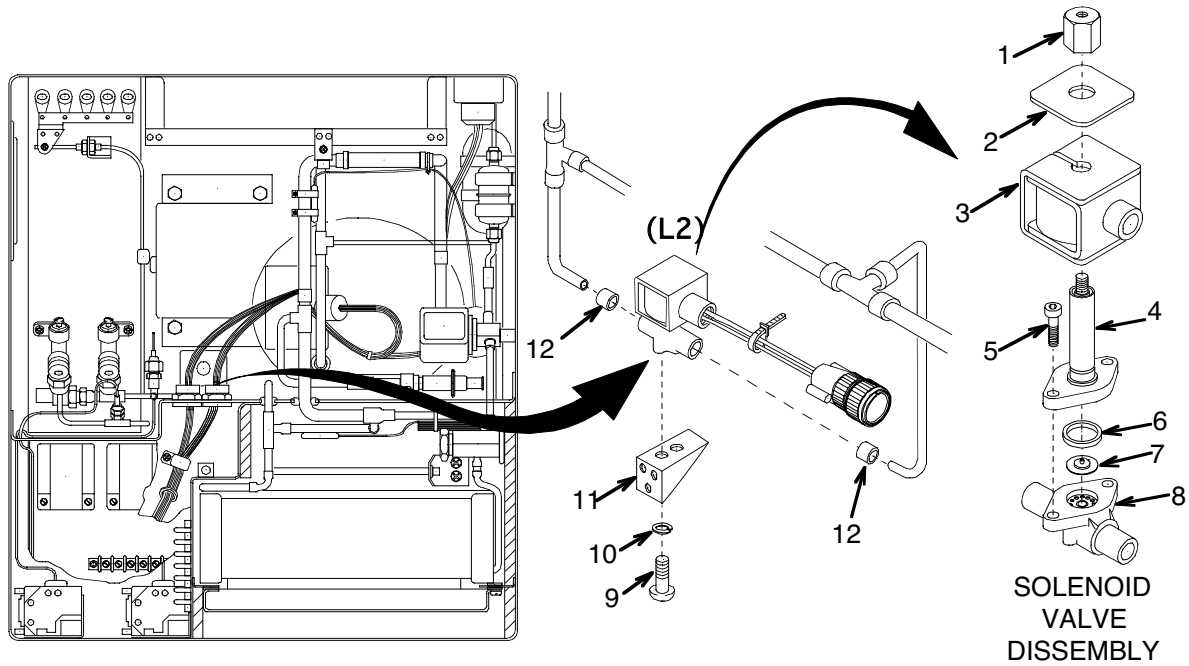

NOTE

FOLLOW-ON MAINTENANCE:
 Install new dehydrator (WP 0070 00)
 Install condenser fan motor (WP 0047 00)
 Install top panels (WP 0016 00)

END OF WORK PACKAGE

DIRECT SUPPORT MAINTENANCE
AIR CONDITIONER, HORIZONTAL, COMPACT
(NSN 4120-01-502-1319)
PRESSURE REGULATOR REPLACEMENT

INITIAL SETUP:**Tools**

Refrigeration Unit Service Tool Kit (WP 0092 00, Item 1)

Materials/Parts

Pressure Regulator
 Lock Washer

Equipment Condition

Remove actuating cylinder (WP 0077 00)

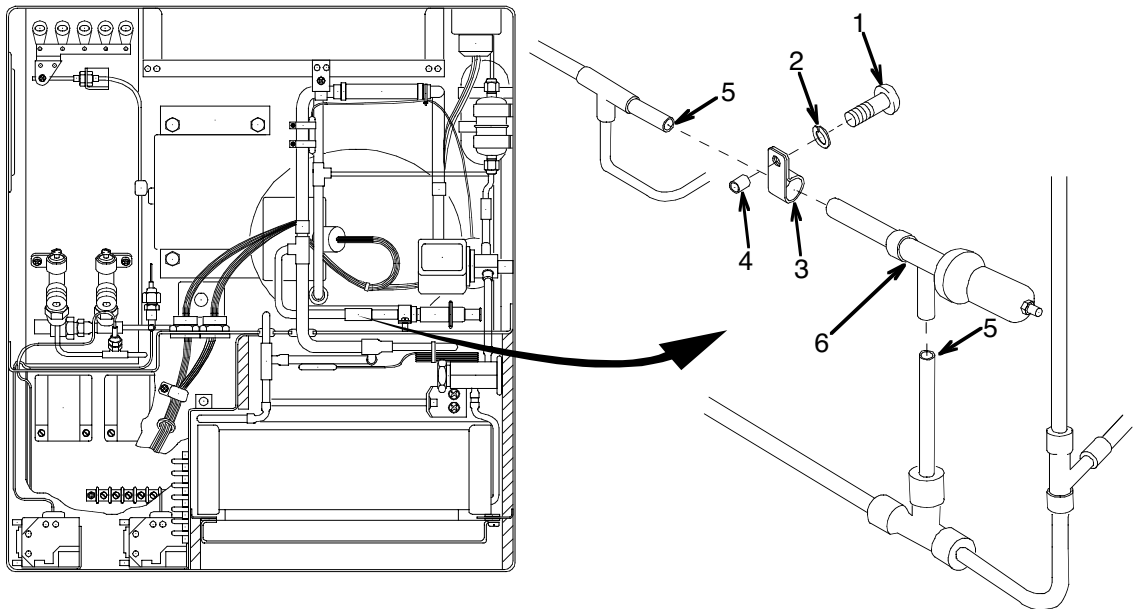
**REPLACEMENT**

1. Remove screw (1), lock washer (2), clamp (3), and post spacer (4).
2. De-breeze two tube connections (5) and remove pressure regulator (6). (See WP 0062 00).
3. Slip the pressure regulator (6) in place.
4. Braze the tubing to the pressure regulator (6) (See WP 0062 00).
5. Secure the pressure regulator (6) with screw (1), lock washer (2), clamp (3), and post spacer (4).

NOTE

FOLLOW-ON MAINTENANCE:
 Install actuating cylinder (WP 0077 00)

END OF WORK PACKAGE

DIRECT SUPPORT MAINTENANCE
AIR CONDITIONER, HORIZONTAL, COMPACT
(NSN 4120-01-502-1319)
ACTUATING CYLINDER REPLACEMENT

INITIAL SETUP:**Tools**

Refrigeration Unit Service Tool Kit (WP 0092 00, Item
1)

Materials/Parts

Actuating Cylinder
Lock Washers (2)

Equipment Condition

Remove top panels (WP 0016 00)
Remove dehydrator (WP 0070 00)

REPLACEMENT

1. Loosen the screw (1) from the mechanical post (2) and slip the push-pull cable wire (3) loose.
2. Disconnect the actuator cylinder (4) from the flare nut (5) on the elbow.
3. Remove two nuts (6) and lock washers (7) and slip the actuator cylinder (4) out of the unit.
4. Align the studs on the actuating cylinder (4) with the holes in the bulkhead and secure with two lock washers (7) and nuts (6) each.
5. Connect the swivel elbow flare nut (5) to the actuating cylinder (4).
6. Insert the control cable (3) into the mechanical post (2). Do not tighten the screw (1).
7. Close the condenser discharge air louvers and tighten the screw (1).

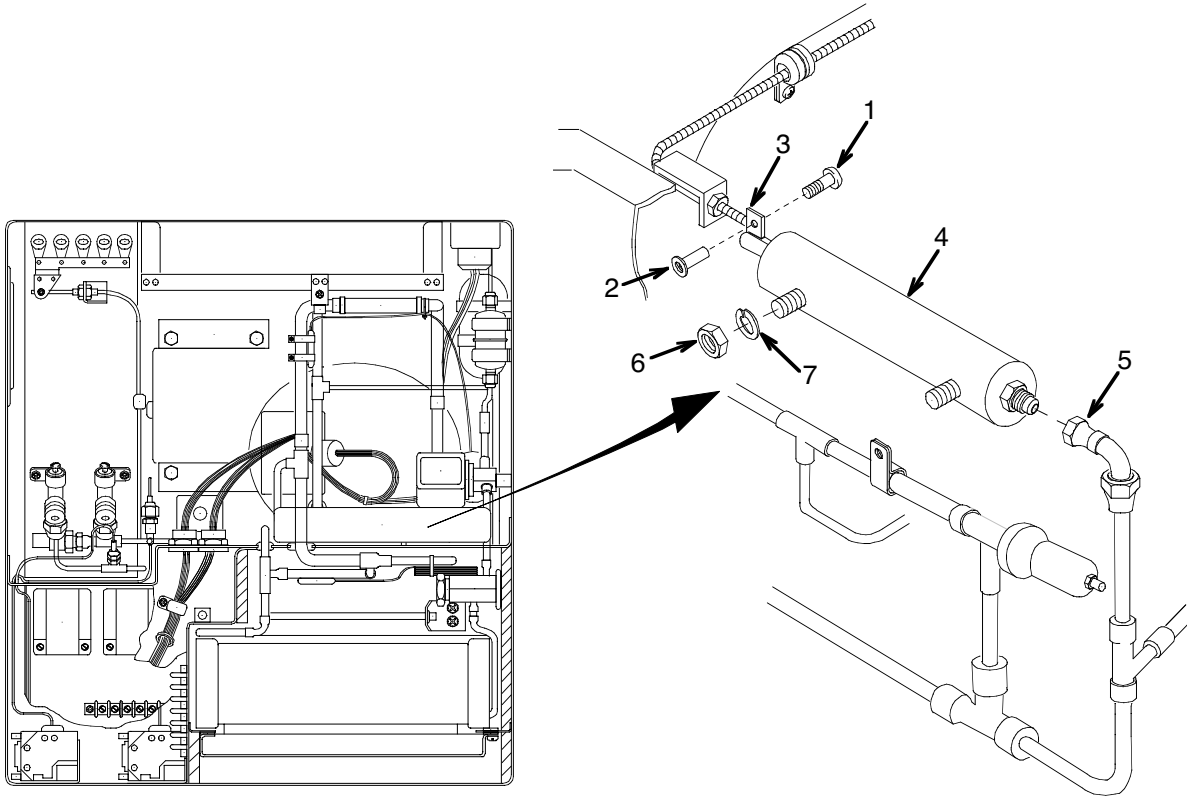

NOTE

FOLLOW-ON MAINTENANCE:
Install new dehydrator (WP 0070 00)
Install top panels (WP 0016 00)

END OF WORK PACKAGE

DIRECT SUPPORT MAINTENANCE
AIR CONDITIONER, HORIZONTAL, COMPACT
(NSN 4120-01-502-1319)

HIGH PRESSURE SWITCH S4 INSPECTION, TESTING, AND REPLACEMENT

INITIAL SETUP:

Tools

Refrigeration Unit Service Tool Kit (WP 0092 00, Item 1)

Materials/Parts

High Pressure Switch
 Lock Washers (3)

Equipment Condition

Remove junction box (WP 0033 00)
 Remove top panels (WP 0016 00)

INSPECTION

Inspect the pressure switch (1) and capillary line for visible signs of damage. Replace if damaged.

TESTING

Press the reset button on the switch (1). Check for continuity between terminals 1 and 2. If there is continuity, the switch is properly closed. If no continuity is found, press and release the reset button again. If there is still no continuity, the switch must be replaced.

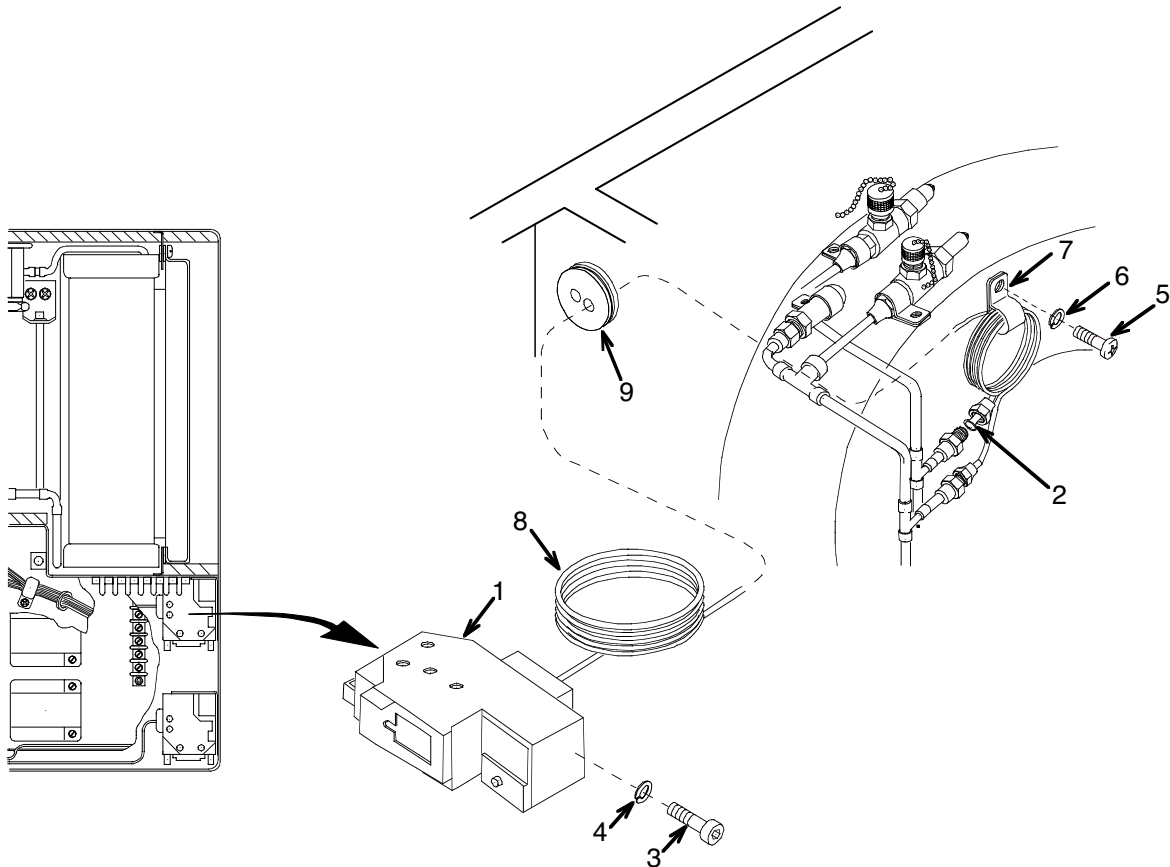

REPLACEMENT

1. Remove the supply air louver (WP 0019 00).
2. Remove the dehydrator (WP 0070 00)
3. Tag and disconnect all wire leads from the high-pressure switch (1).
4. Disconnect the flare nut (2) at the end of the capillary line switch (1).
5. Remove the mist eliminator bracket (WP 0021 00).
6. Remove two screws (3) and lock washers (4) from the switch (1).
7. Remove screw (5), lock washer (6), and clamp (7) from the capillary line (8).
8. Carefully remove the capillary line (8) through the grommet (9) and remove the switch (1)
9. Insert the capillary line (8) through the grommet hole (9) in the bulkhead.
10. Connect the flare nut (2).
11. Secure the switch (1) with two screws (3) and lock washers (4).
12. Carefully route the capillary line (8) and position it so that it will not touch the junction box.
13. Secure the capillary line (8) with the clamp (7), screw (5), and lock washer (6).
14. See WP 0013 00, Wiring Diagram. Connect all wire leads and remove tags.

NOTE

FOLLOW-ON MAINTENANCE:
Install new dehydrator (WP 0070 00)
Install mist eliminator bracket (WP 0021 00)
Install junction box (WP 0033 00)
Install supply air louver (WP 0019 00)
Install top panels (WP 0016 00)

END OF WORK PACKAGE

DIRECT SUPPORT MAINTENANCE
AIR CONDITIONER, HORIZONTAL, COMPACT
(NSN 4120-01-502-1319)

LOW PRESSURE SWITCH (S5) INSPECTION, TESTING, AND REPLACEMENT

INITIAL SETUP:

Tools

Refrigeration Unit Service Tool Kit (WP 0092 00, Item 1)

Equipment Condition

Remove junction box (WP 0033 00)
 Remove top panels (WP 0016 00)

Materials/Parts

Low Pressure Switch S5
 Lock Washers (2)
 Tie Down Straps

INSPECTION

Inspect the pressure switch (1) and capillary line for visible signs of damage. Replace if damaged.

TESTING

Press the reset button on the switch (1). Check for continuity between terminals 1 and 2. If there is continuity, the switch is properly closed. If no continuity is found, press and release the reset button again. If there is still no continuity, the switch must be replaced.

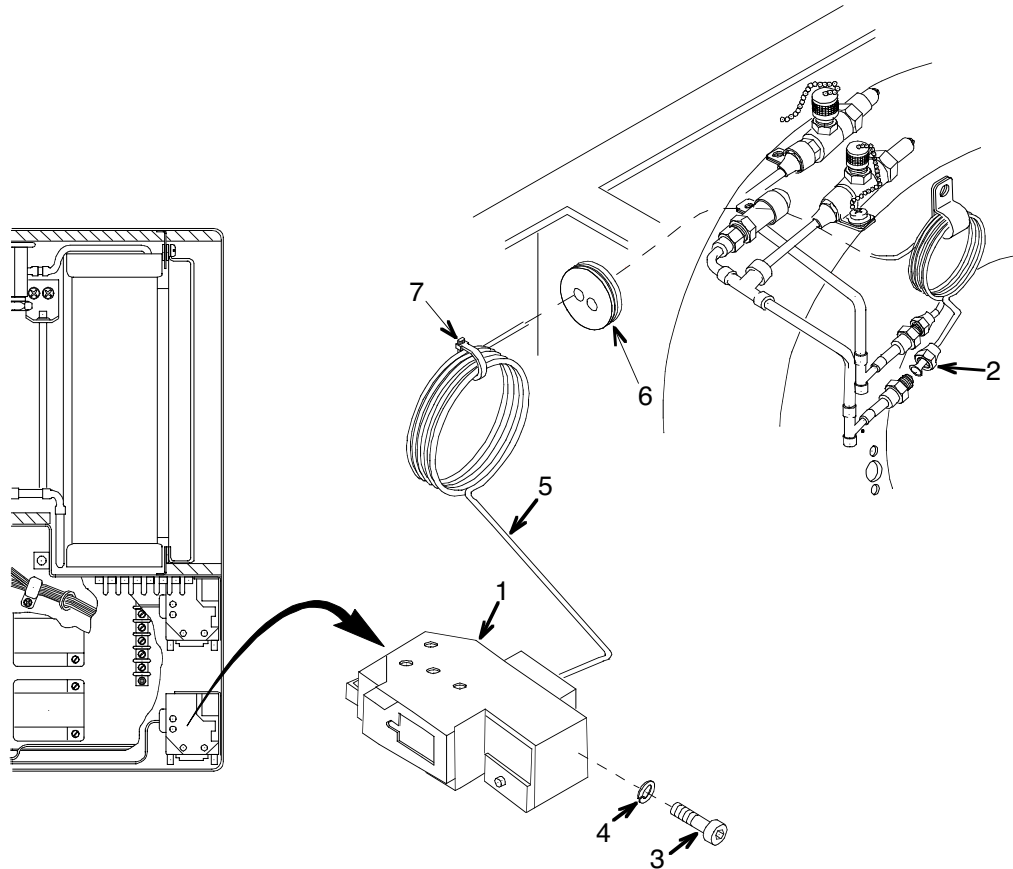

REPLACEMENT

1. Remove the dehydrator (WP 0070 00)
2. Tag and disconnect all wire leads from the low-pressure switch (1).
3. Disconnect the flare nut (2) from the switch (1) at the end of the capillary line.
4. Remove two screws (3) and lock washers (4) from the switch (1).
5. Carefully remove the capillary line (5) through the grommet (6) and remove the switch (1).
6. Insert the capillary line (5) through the grommet hole (6) in the bulkhead.
7. Connect the flare nut (2).
8. Secure the switch (1) with two screws (3) and lock washers (4).
9. Carefully route the capillary line (5) and position so it will not touch the junction box.
10. Coil and secure excess capillary line (5) with a tie down strap (7).
11. See the Wiring Diagram. Connect all wire leads and remove tags.

NOTE

FOLLOW-ON MAINTENANCE:
Install new dehydrator (WP 0070 00)
Install junction box (WP 0033 00)
Install top panels (WP 0016 00)

END OF WORK PACKAGE

DIRECT SUPPORT MAINTENANCE
AIR CONDITIONER, HORIZONTAL, COMPACT
(NSN 4120-01-502-1319)
SERVICE (CHARGING) VALVES REPLACEMENT

INITIAL SETUP:

Tools

Refrigeration Unit Service Tool Kit (WP 0092 00, Item 1)

Materials/Parts

Service Charging Valve
 Lock Washer

Equipment Condition

Remove top panels (WP 0016 00)
 Remove dehydrator (WP 0070 00)

REPLACEMENT

1. Remove screw (1), lock washer (2), flat washer (3), cap and chain (4), and loop clamp (5) from the valve (6) to be replaced.
2. Disconnect the flare nut (7) and remove the valve (6).

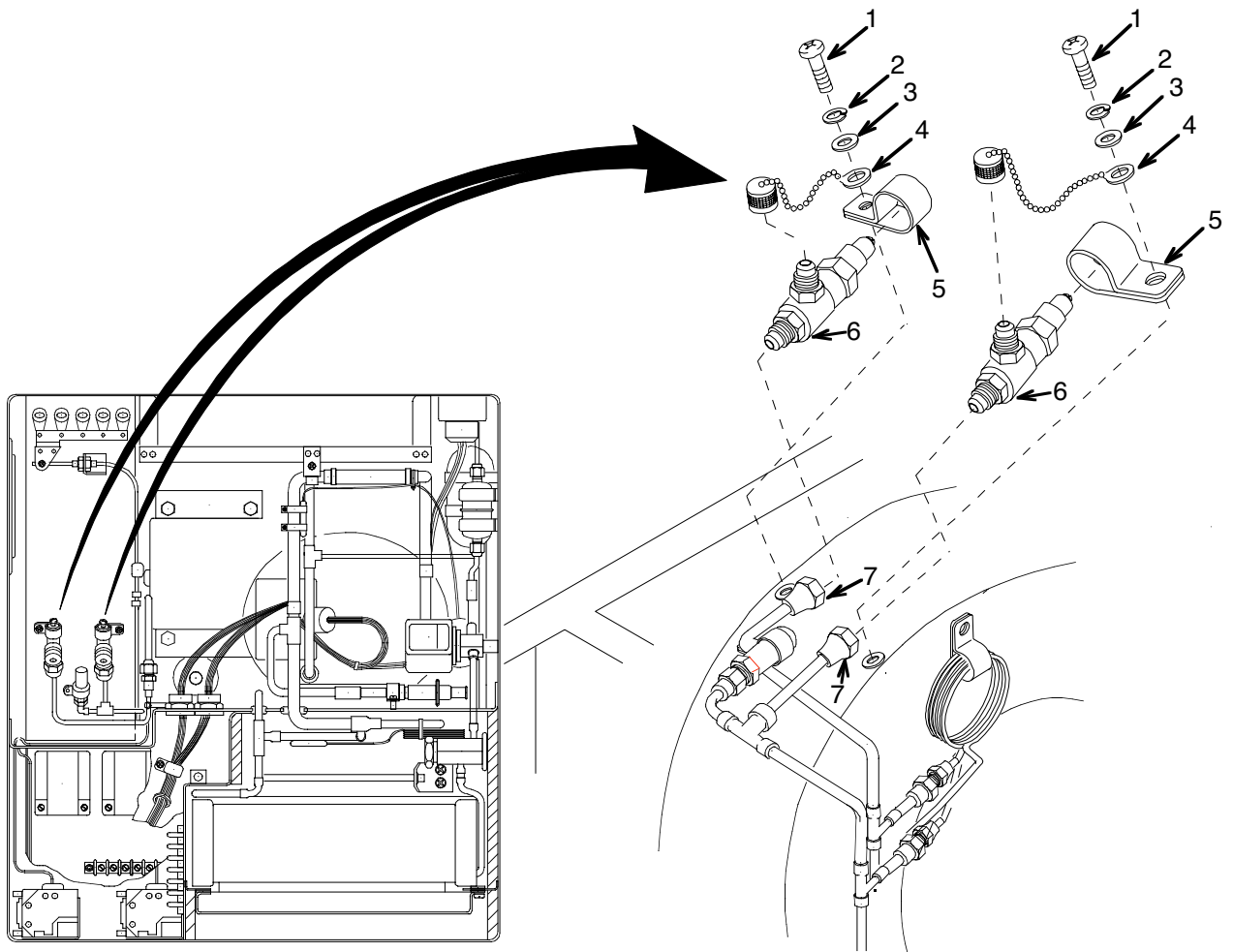

3. Slip the valve (6) into place and tighten the flare nut (7).
4. Secure the valve (6) and cap and chain (4) with the loop clamp (5), screw (1), lock washer (2), and flat washer (3).

NOTE

FOLLOW-ON MAINTENANCE:
Install new dehydrator (WP 0070 00)
Install top panels (WP 0016 00)

END OF WORK PACKAGE

DIRECT SUPPORT MAINTENANCE
AIR CONDITIONER, HORIZONTAL, COMPACT
(NSN 4120-01-502-1319)
PRESSURE RELIEF VALVE REPLACEMENT

INITIAL SETUP:**Tools**

Refrigeration Unit Service Tool Kit (WP 0092 00, Item 1)

Materials/Parts

Pressure Relief Valve
 Lock Washers (2)

Equipment Condition

Remove top panels (WP 0016 00)
 Remove dehydrator (WP 0070 00)

REPLACEMENT

1. Remove screw (1), lock washer (2), flat washer (3), and chain (4) from the clamp (5).
2. Remove screw (6), lock washer (7), flat washer (8), and loop clamp (9).
3. Hold the fitting (10) and remove the valve (11).

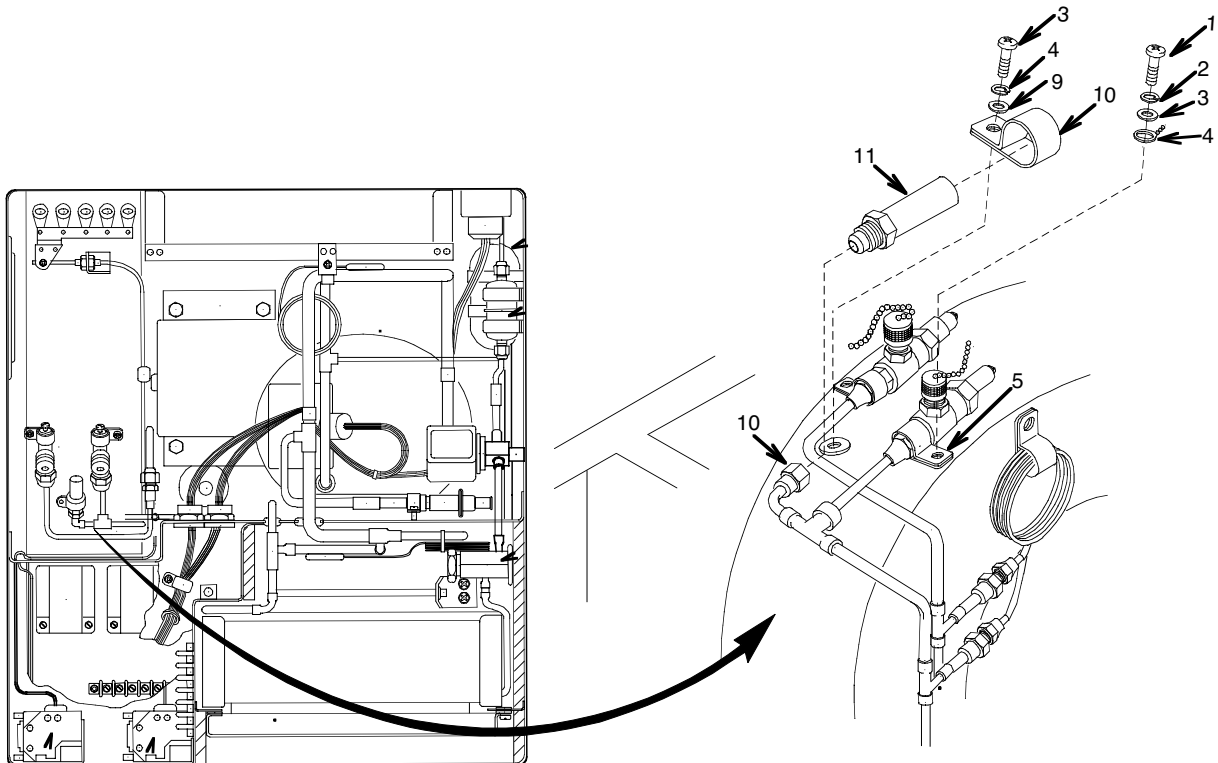

4. Hold the fitting (10) and install the new valve (11).
5. Secure the valve (11) with the clamp (9), screw (6), lock washer (7), and flat washer (8).
6. Install the clamp (5) and chain (4) with the screw (1), lock washer (2), and flat washer (3).

NOTE

FOLLOW-ON MAINTENANCE:
Install new dehydrator (WP 0070 00)
Install top panels (WP 0016 00)

END OF WORK PACKAGE

DIRECT SUPPORT MAINTENANCE
AIR CONDITIONER, HORIZONTAL, COMPACT
(NSN 4120-01-502-1319)
CONDENSER COIL REPLACEMENT

INITIAL SETUP:**Tools**

Refrigeration Unit Service Tool Kit (WP 0092 00, Item 1)

Gloves (WP 0092 00, Item 2)

Equipment Condition

Remove dehydrator (WP 0070 00)

Purge refrigerant system (WP 0061 00)

Remove condenser air inlet guard (WP 0017 00)

Materials/Parts

Condenser Coil

Lock Washers (3)

REPLACEMENT

1. Remove two screws (Item 1), lock washers (2), and mounting plate (3).
2. Remove four screws (4) and two clamps (5) from the receiver (6).
3. Remove screw (7), nut (8), lock washer (9), and clamp (10) from coil (11).
4. De-braze the tube connection (12) on the coil (11) (WP 0062 00).

WARNING

When handling coils, wear gloves to avoid cuts and reduce fin damage.

5. Carefully lift the condenser coil (11), sight glass (13), and receiver (6) up and out of the unit.
6. Remove (de-braze) the receiver (6). (WP 0062 00).
7. Braze the receiver (6) to the new coil. (WP 0062 00)
8. Remove (de-braze) the sight glass (13). (WP 0062 00)
9. Braze the sight glass (13) to the new coil. (WP 0062 00).

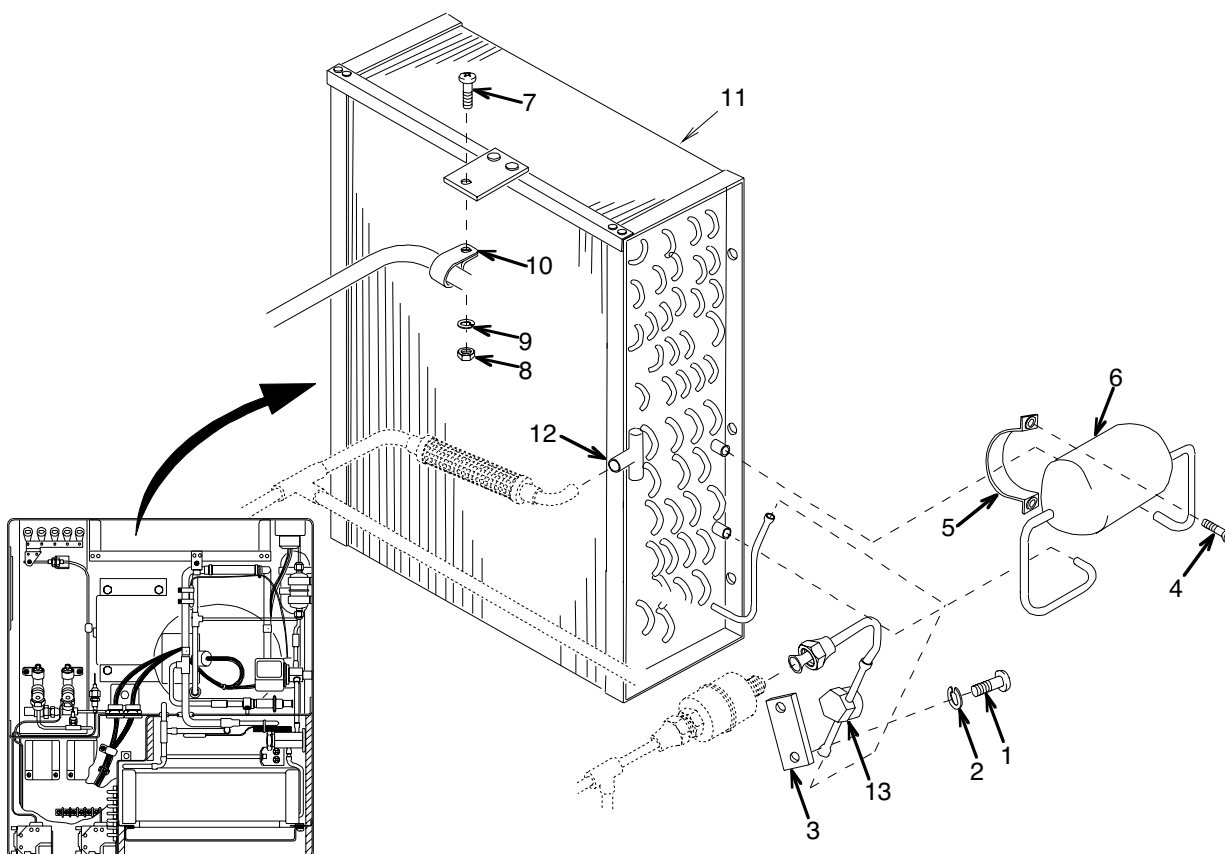

WARNING

When handling the coils, wear gloves to avoid cuts and reduce fin damage.

10. Carefully place the coil (11) into its position in the unit.
11. Braze tube connections (12) to the coil. (WP 0062 00).
12. Secure the receiver (6) with two clamps (5) and screws (4).
13. Secure the sight glass (13) with the mounting plate (3), two screws (1), and lock washers (2).
14. Secure the clamp (10) with the screw (7), lock washer (9), and nut (8).

NOTE

FOLLOW-ON MAINTENANCE:
 Install new dehydrator (WP 0070 00)
 Install condenser air inlet guard (WP 0017 00)

END OF WORK PACKAGE

DIRECT SUPPORT MAINTENANCE
AIR CONDITIONER, HORIZONTAL, COMPACT
(NSN 4120-01-502-1319)
LIQUID INDICATOR (SIGHT GLASS) REPLACEMENT

INITIAL SETUP:**Tools**

Refrigeration Unit Service Tool Kit (WP 0092 00, Item
1)

Equipment Condition

Remove condenser coil (WP 0082 00)

Materials/Parts

Liquid Indicator

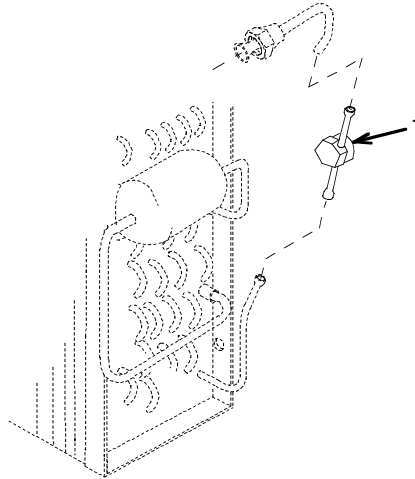
**REPLACEMENT**

1. De-braze and remove the liquid indicator (1). (WP 0062 00).
2. Place the liquid indicator (1) on the tubing ends and braze them. (WP 0062 00).

NOTE

FOLLOW-ON MAINTENANCE:
Install condenser coil (WP 0082 00)

END OF WORK PACKAGE

DIRECT SUPPORT MAINTENANCE
AIR CONDITIONER, HORIZONTAL, COMPACT
(NSN 4120-01-502-1319)
RECEIVER REPLACEMENT

INITIAL SETUP:**Tools**

Refrigeration Unit Service Tool Kit (WP 0092 00, Item
1)

Materials/Parts

Receiver

Equipment Condition

Remove condenser coil (WP 0082 00)

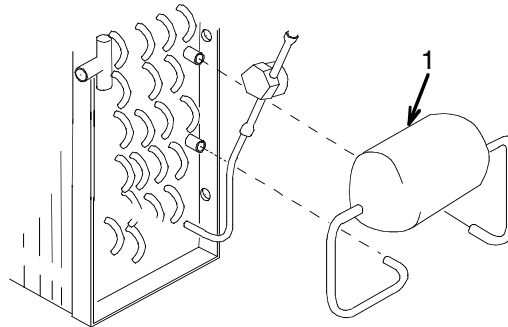
**REPLACEMENT**

1. De-braze and remove the receiver (1). (See WP 0062 00).
2. Place the receiver (1) on the tubing ends and braze. (WP 0062 00).

NOTE

FOLLOW-ON MAINTENANCE:
Install condenser coil (WP 0082 00)

END OF WORK PACKAGE

DIRECT SUPPORT MAINTENANCE
AIR CONDITIONER, HORIZONTAL, COMPACT
(NSN 4120-01-502-1319)
COMPRESSOR TESTING, REMOVAL, REPAIR, AND INSTALLATION

INITIAL SETUP:

Tools

Refrigeration Unit Service Tool Kit (WP 0092 00, Item 1)

Self-locking Nuts
 Tie Down Straps

Equipment Condition

Remove top rear panel (WP 0016 00)

Materials/Parts

Compressor
 Thermal Overload Switch
 Crank-case Heater
 Connector J10

Personnel Required

2

WARNING

If compressor is removed due to burnout, be sure to avoid touching the compressor sludge when lifting. Acid in sludge can cause burns.

TESTING

1. Disconnect the wiring harness P10 from J10.
2. (On 3-Phase Models Only) Set the multimeter to its lowest OHMS scale and check for continuity between pins G and F in the connector J10. If continuity does not exist between these pins, the heater is bad and should be replaced.
3. Check for continuity between pins D and E. If continuity does not exist (and the compressor has had time to cool down), the compressor motor internal overload witch (S8) is bad. On 3-Phase units, replace the compressor.
4. Check for continuity between pins A and B, B and C, and A and C. There should be continuity between each pair of pins. If no continuity exists, the compressor motor is bad and the compressor should be replaced.
5. Check for continuity between pins A, B, and C and the compressor body. NO continuity should exist. If continuity does exist, the compressor motor is bad and the compressor should be replaced.
6. Inspect the J10 connector for loose, broken, or otherwise damaged pins or connector threads. Replace is damaged.

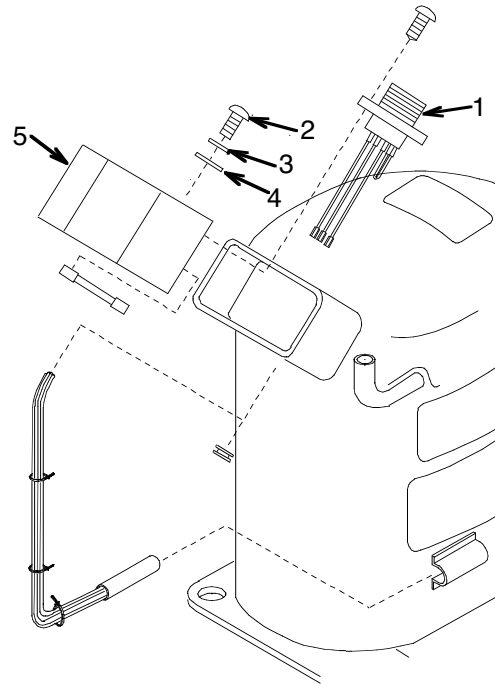
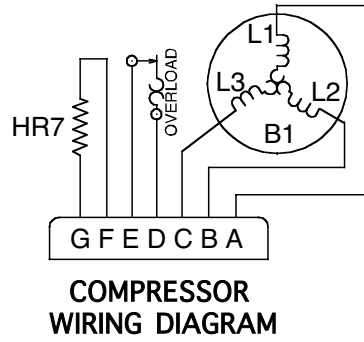

REPAIR

A. Crankcase Heater

- 1) Disconnect the heater leads from pins F and G of J10 (Figure 5-32, Item 1). Pull leads through the grommet (2).
- 2) Pull the heater (3) from the mounting clip.
- 3) Place the new heater (3) in the mounting clip.
- 4) Run the heater wires through the grommet (2).
- 5) Connect the heater leads to J10, pins F and G.
- 6) Secure the heater wires with tie down straps.

B. Connector (J10)

- 1) Remove four screws (9) and nut plate (11).
- 2) Tag and unsolder all wire leads.
- 3) See the Wiring Diagram. Solder all leads to the new connector and remove tags.
- 4) Secure the connector (1) with four screws (9) and nut plate (11).

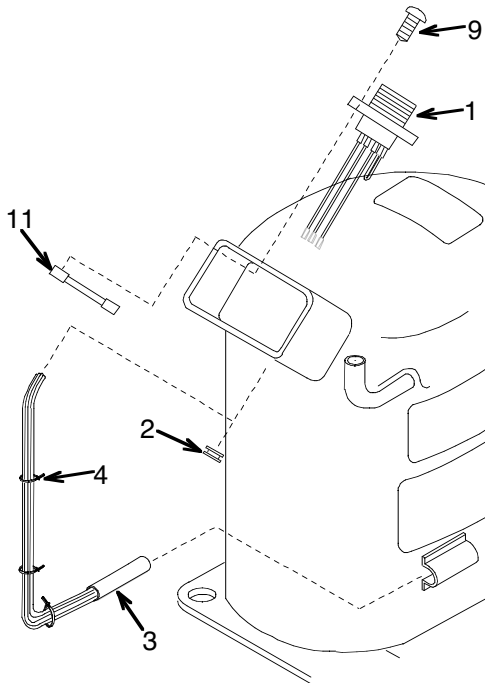

REMOVAL

1. Remove the dehydrator (WP 0070 00).
2. Purge the refrigerant system (WP 0061 00).
3. De-braze the compressor tubes (WP 0062 00).
4. Lift and support the air conditioner to gain access to the bottom of the housing.
5. Loosen four access panel screws (1) in the bottom of the unit and swing the access panels (2) out of the way.
6. Remove four self-locking nuts (3), eight flat washers (4), eight shims (5), and four screws (6).

WARNING

If compressor is removed due to burnout, avoid touching the compressor sludge when lifting. Acid in sludge can cause burns.

7. Carefully lift the compressor (7) from the unit.
8. Check compressor to determine if motor burnout is indicated:
 - a) Tip the compressor toward the discharge port and drain a small quantity of oil into a clear gas container.
 - b) If the oil is clean and clear and does not have a burnt-acid odor, the compressor DID NOT fail due to motor burnout. Install a new compressor.
 - c) If the oil is black, contains sludge, and does have a burnt-acid odor, the compressor HAS failed due to motor burnout. Flush the refrigerant system prior to installing the new compressor.

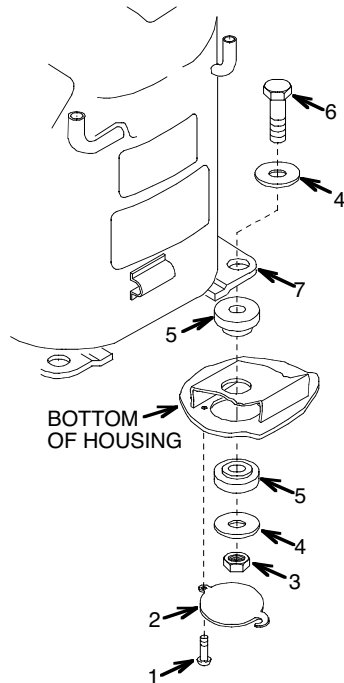

INSTALLATION

CAUTION

The compressor is supplied with a complete charge of oil. Be sure that the oil is not lost when handling and installing the compressor.

1. If any refrigeration piping was disconnected and removed with the compressor, transfer the piping to the replacement compressor.
2. Place four shims (5) into the unit on the mounting channels.
3. Carefully set the compressor (7) down onto the shims (5).
4. Install four flat washers (4) and screws (6).
5. Lift and support the air conditioner to gain access to the bottom of the housing.
6. Install four shims (5), flat washers (4), and self-locking nuts (3).
7. Swing four access panels (2) into place and tighten the screws (1).
8. Braze the tube connections.
9. Connect the P10 connector.
10. Replace the dehydrator.

NOTE

FOLLOW-ON MAINTENANCE:
Install top, rear panel (WP 0016 00)

END OF WORK PACKAGE

DIRECT SUPPORT MAINTENANCE
AIR CONDITIONER, HORIZONTAL, COMPACT
(NSN 4120-01-502-1319)
TUBING AND FITTING REPLACEMENT

INITIAL SETUP:**Tools**

Refrigeration Unit Service Tool Kit (WP 0092 00, Item
1)

Equipment Condition

Remove top panels (WP 0016 00)
Remove dehydrator (WP 0070 00)
Purge refrigerant system (WP 0061 00)

REPLACEMENT

Replace tubing and fittings only with equal material, grade, size, length, and shape as the item removed.

NOTE

FOLLOW-ON MAINTENANCE:
Install new dehydrator (WP 0070 00)

END OF WORK PACKAGE

CHAPTER 9.

GENERAL SUPPORT MAINTENANCE INSTRUCTIONS

**GENERAL SUPPORT MAINTENANCE
AIR CONDITIONER, HORIZONTAL, COMPACT
(NSN 4120-01-502-1319)
GENERAL INFORMATION**

GENERAL

The only items restricted to the general support maintenance level by the Maintenance Allocation Chart (MAC) are the repair and replacement of insulation or lift fittings on the housing and the replacement of the cabinet base. General support maintenance, however, may be called upon (at times) to perform any or all of the MAC items listed for unit and direct support maintenance for rehabilitation or overhaul of an air conditioner.

END OF WORK PACKAGE

GENERAL SUPPORT MAINTENANCE
AIR CONDITIONER, HORIZONTAL, COMPACT
(NSN 4120-01-502-1319)
HOUSING REPAIR AND REPLACEMENT

INITIAL SETUP:**Tools**

Refrigeration Unit Service Tool Kit (WP 0092 00, Item
 1)
 Torch Set

Materials/Parts

Insulation/Gasket (WP 0094 00)
 Adhesive Remover
 Adhesive (WP 0094 00, Item 2)

Equipment Condition

Disconnect power at the power source

WARNING

Adhesive remover is flammable and the vapors can be explosive. Repeated or prolonged skin contact or inhalation of vapors can be toxic. Use in a well-ventilated area, wear gloves, and keep away from sparks or flame.

NOTE

Repairs are limited to broken or cracked welds, straightening of bent or dented sheet metal, and replacement of handles, gaskets, insulation, and riv-nuts as well as some small sheet metal parts by drilling out rivets and insulation of replacement parts.

REPAIR

1. Disassemble the unit as necessary and make repairs as indicated.
2. Minor dents and bent edges can be straightened using common sheet metal repair procedures.
3. Should touch up or refinishing be necessary, refer to TM 43-0139.

NOTE

Housing replacement requires total unit disassembly. Normally, if the unit is damaged to this extent, the whole unit should be replaced.

If housing replacement is attempted, see the individual installation instructions of components for reinstallation of items removed.

REPLACEMENT**Gasket and Insulation Replacement**

1. Use only the gaskets, insulation, or nameplates identified in TM9-4120-400-24P.
2. Remove as much old gasket or insulation material from the unit as possible by pulling or scraping it away from the metal surface.

WARNING

Adhesive remover is flammable and the vapors can be explosive. Repeated or prolonged skin contact or inhalation of vapors can be toxic. Use in a well-ventilated area, wear gloves, and keep away from sparks or flame.

3. Soften and remove the old adhesive and material residue, using adhesive remover and a stiff brush.
4. Coat all mating surfaces of the metal and material with adhesive. Let both surfaces air-dry until adhesive is tacky, but will not stick to fingers.
5. Starting at one end, carefully attach material to the metal. Press firmly into place.

NOTE

FOLLOW-ON MAINTENANCE:
Connect power at the power source

END OF WORK PACKAGE

CHAPTER 10.

**OPERATOR'S, UNIT, DIRECT SUPPORT, AND GENERAL SUPPORT
MAINTENANCE INSTRUCTIONS**

OPERATOR'S, UNIT, DIRECT SUPPORT, AND GENERAL SUPPORT MAINTENANCE
AIR CONDITIONER, HORIZONTAL, COMPACT
(NSN 4120-01-502-1319)
ILLUSTRATED LIST OF MANUFACTURED ITEMS

INTRODUCTION**Scope**

This section includes complete instructions for making the items authorized for manufacturing or fabrication at the unit, direct support, and general support maintenance.

A part number index in alphanumeric order is provided for cross-referencing the part number of the item to be manufactured to the figure, which covers the fabrication criteria.

All bulk materials needed for the manufacture of an item that are listed by part number or specification number in a tabular list on the illustration.

Manufactured Items Part Number Index

PART NUMBER	FIGURE NUMBER	PART NUMBER	FIGURE NUMBER
13216E5880/2	11	13225E8451/28	31
13216E5880/3	13	13225E8451/40	24
13216E5881/3	3	13225E8451/41	18
13216E5881/5	1	13225E8451/42	23
13216E5881/6	2	13225E8451/43	34
13216E5881/8	3	13225E8451/44	26
13216E5891-1/2	35	13225E8451/45	18
13216E5895/3	19	13225E8451/46	28
13216E5896/2	18	13225E8451/47	27
13216E5899/3	20	13225E8451/48	30
13216E6116-2/3	18	13225E8451/49	18
13216E6151-1	15	13225E8451/50	21
13216E6151-4	15	13225E8451/51	33
13216E6151-5	15	13225E8451/52	33
13220E1352/3	12	13225E8451/53	25
13225E8422/3	8	13225E8451/61	22
13225E8422/4	9	13225E8451/62	3
13225E8422/5	10	13225E8451/64	29
13225E8423/2	3	13225E8455/223	14
13225E8423/4	4	13225E8458/3	5
13225E8450/251	16	13225E8458/4	6
13225E8450/283	17	13225E8458/5	7
13225E8451/25	31		

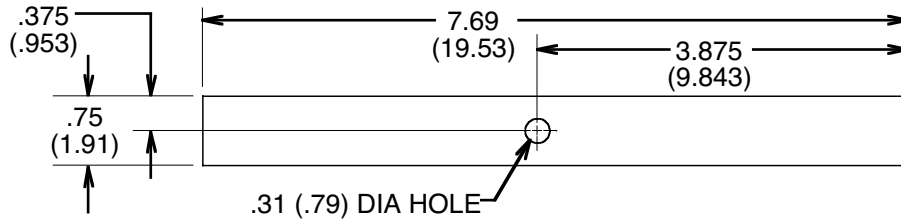

NOTE
1. FABRICATE FROM NSN 9320-00-814-4583 STOCK

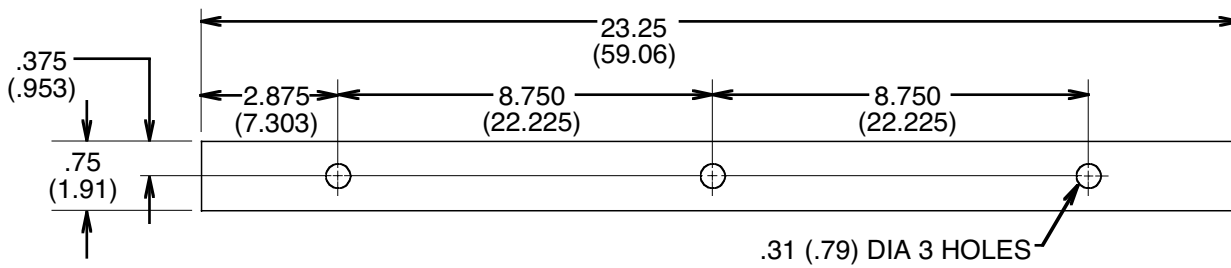

NOTE
1. FABRICATE FROM NSN 9320-00-814-4583 STOCK

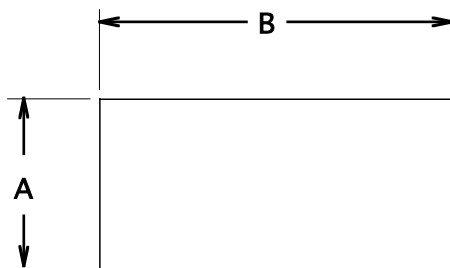

3.75 (9.53)	7.81 (19.84)	13225E8451/62
3.00 (7.62)	4.50 (11.43)	13225E8423/4
3.25 (8.26)	11.75 (29.85)	13216E5881/8
7.69 (19.53)	21.75 (55.25)	13216E5881/3
A DIM	B DIM	PART NUMBER

NOTE
1. FABRICATE FROM AMS3570/SH-1/4THK FLEXIBLE POLYURETHANE FOAM, OPEN CELL, MEDIUM FLEXIBILITY, 2.5 LB PER CU FT, .25 (.64) STK

Figures 1, 2, and 3.

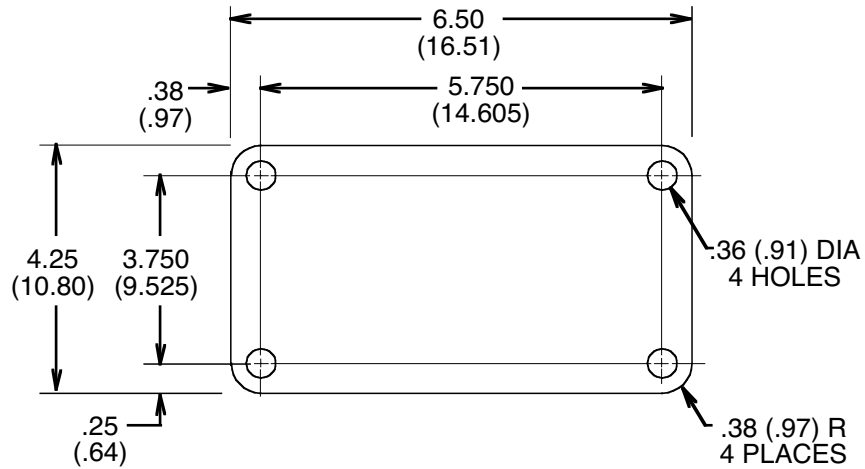

NOTE

1. FABRICATE FROM NSN 9320-01-N80-1132 STOCK

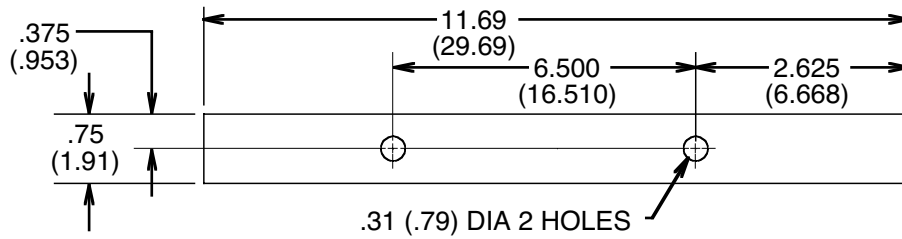

NOTE

1. FABRICATE FROM NSN 9320-01-N80-1132 STOCK

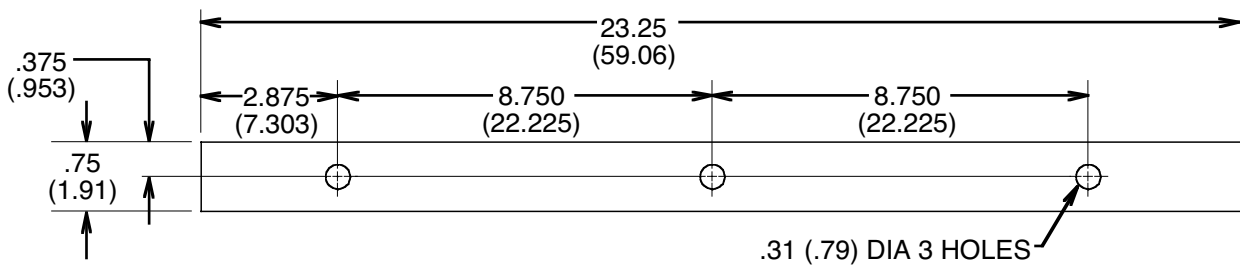

NOTE

1. FABRICATE FROM NSN 9320-01-N80-1132 STOCK

Figures 4, 5, and 6.

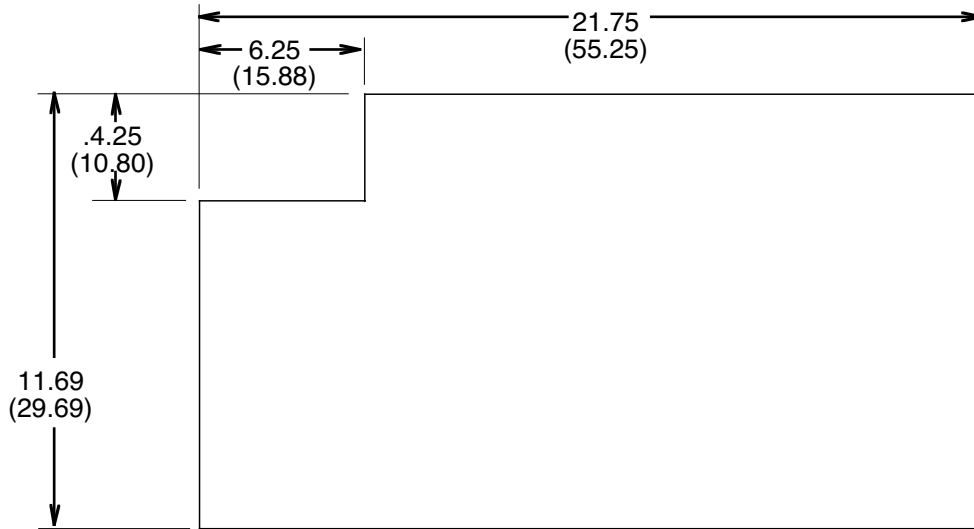

NOTE
1. FABRICATE FROM AMS3570/SH-1/4THK FLEXIBLE POLYURETHANE FOAM, OPEN CELL, MEDIUM FLEXIBILITY, 2.5 LB PER CU FT, .25 (.64) STK

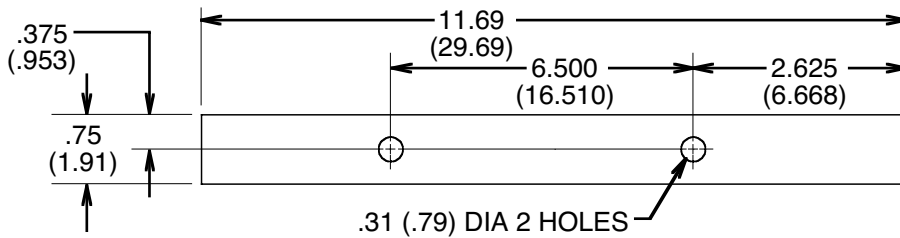

NOTE
1. FABRICATE FROM NSN 9320-01-N80-1132 STOCK

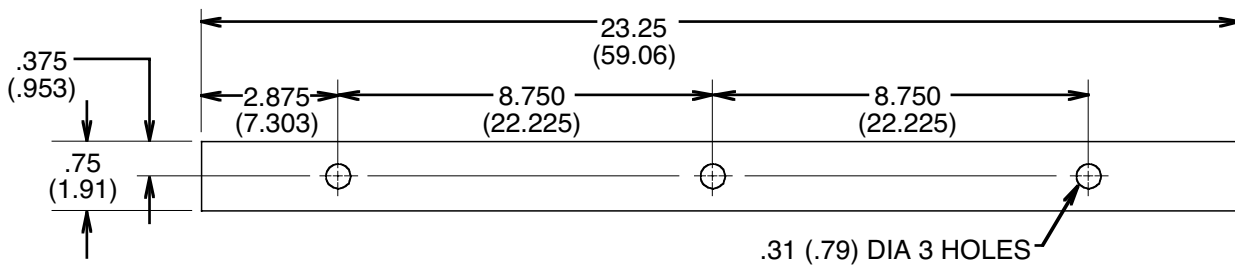

NOTE
1. FABRICATE FROM NSN 9320-01-N80-1132 STOCK

Figures 7, 8, and 9.

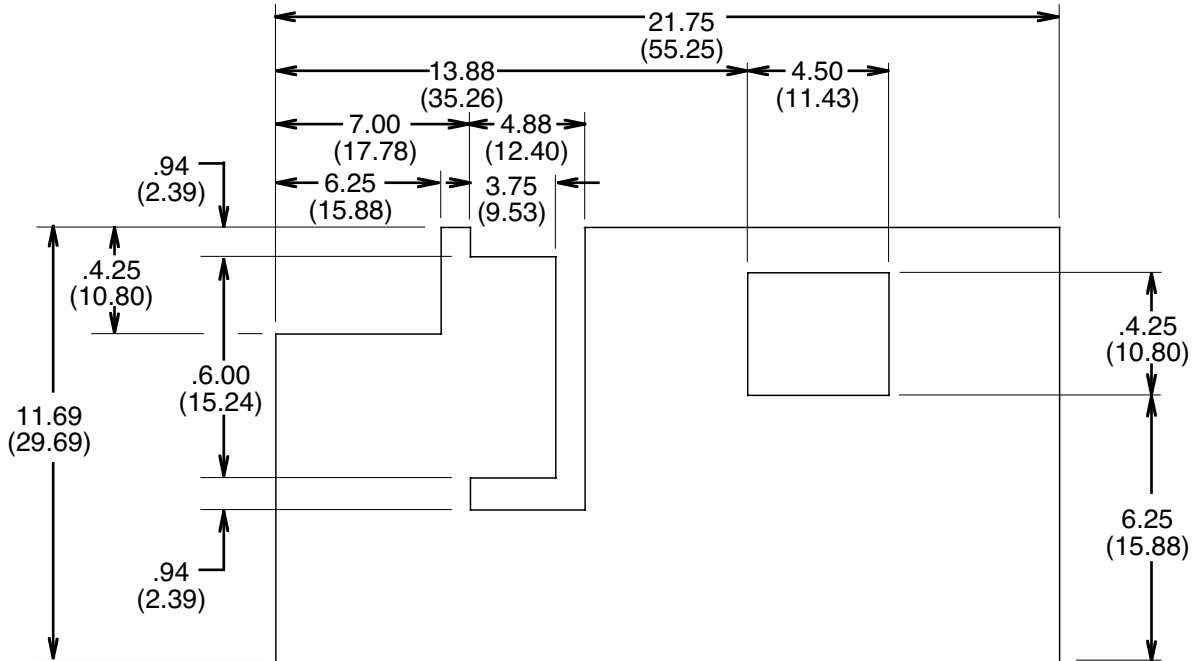

NOTE

- FABRICATE FROM AMS3570/SH-1/4THK FLEXIBLE POLYURETHANE FOAM, OPEN CELL, MEDIUM FLEXIBILITY, 2.5 LB PER CU FT, .25 (.64) STK

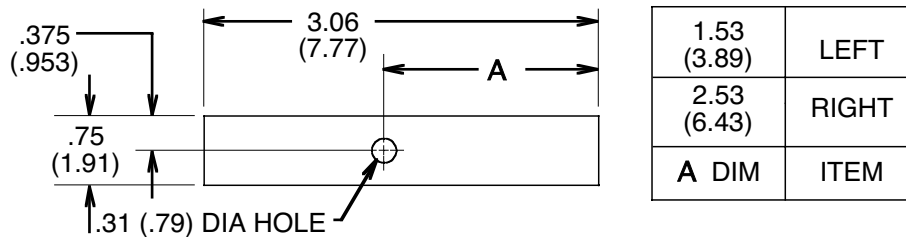

NOTE

- FABRICATE FROM NSN 9320-01-N80-1132 STOCK

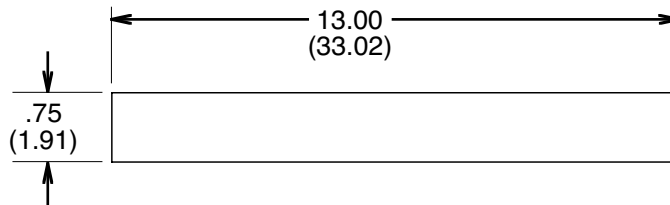

NOTE

- FABRICATE FROM NSN 9320-00-814-4583 STOCK

Figures 10, 11, and 12.

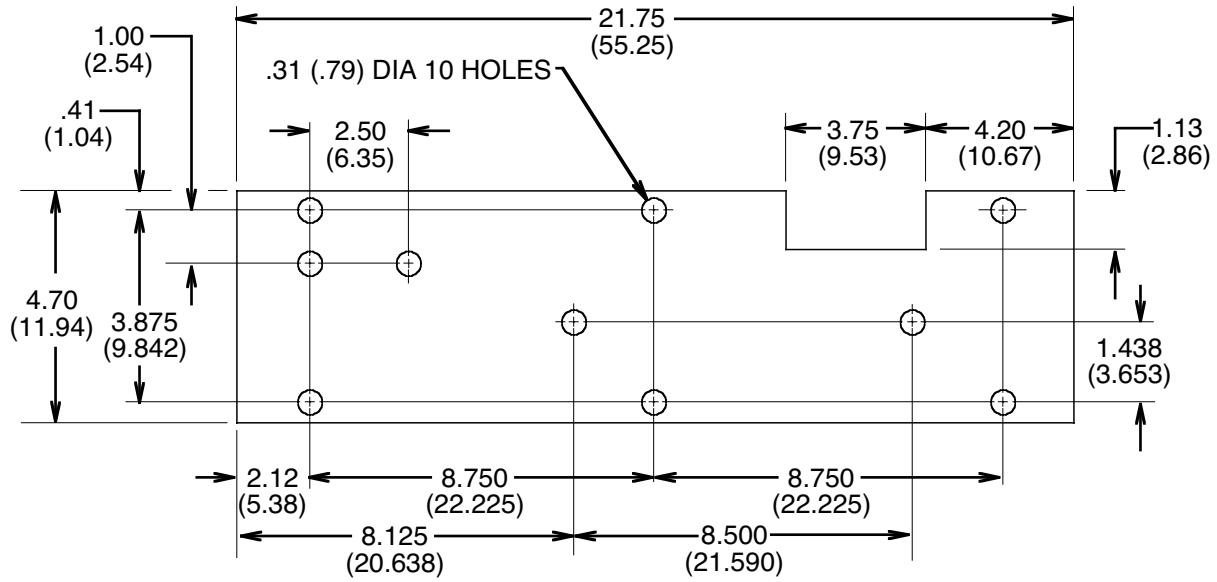

NOTE

- FABRICATE FROM AMS3570/SH-1/4THK FLEXIBLE POLYURETHANE FOAM, OPEN CELL, MEDIUM FLEXIBILITY, 2.5 LB PER CU FT, .25 (.64) STK

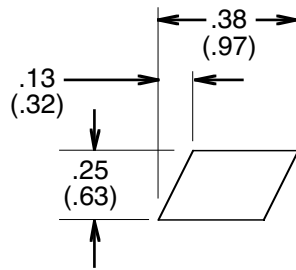

NOTE

- FABRICATE FROM NSN 9320-00-814-4583 STOCK

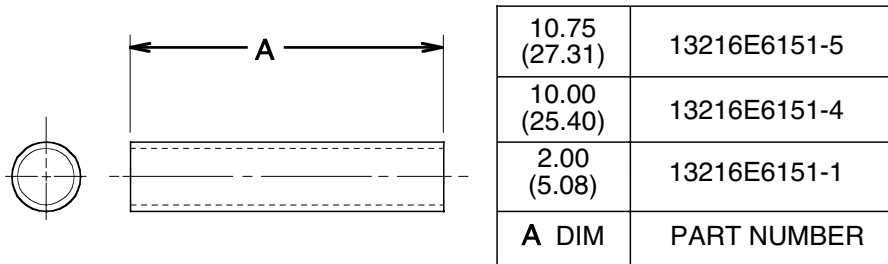

NOTE

- FABRICATE FROM NSN 9330-01-214-8452

Figures 13, 14, and 15.

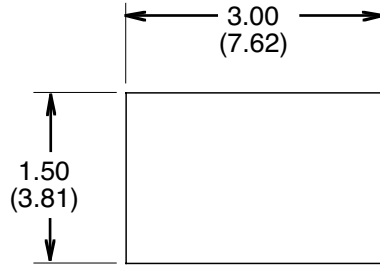

NOTE

1. FABRICATE FROM NSN 5640-00-237-4781 STK

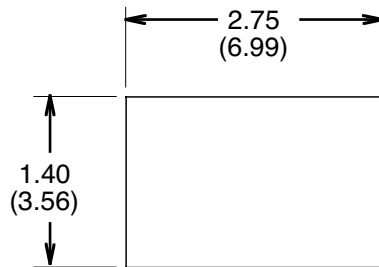

NOTE

1. FABRICATE FROM ASTM-D-2000M2EC510A14 .25 THK STK

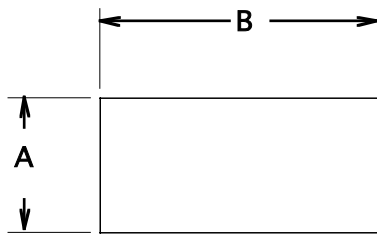

1.00 (2.54)	1.00 (2.54)	13225E8451/49
8.02 (20.37)	9.41 (23.90)	13225E8451/45
8.02 (20.37)	8.12 (20.62)	13225E8451/41
1.13 (2.87)	3.50 (8.89)	13216E6116-2/3
1.13 (2.87)	6.69 (16.99)	13216E5896/2
A DIM	B DIM	PART NUMBER

NOTE

1. FABRICATE FROM AMS3570/SH-1/2THK FLEXIBLE POLYURETHANE FOAM, OPEN CELL, MEDIUM FLEXIBILITY, 2.5 LB PER CU FT, .50 (1.27) STK

Figures 16, 17, and 18.

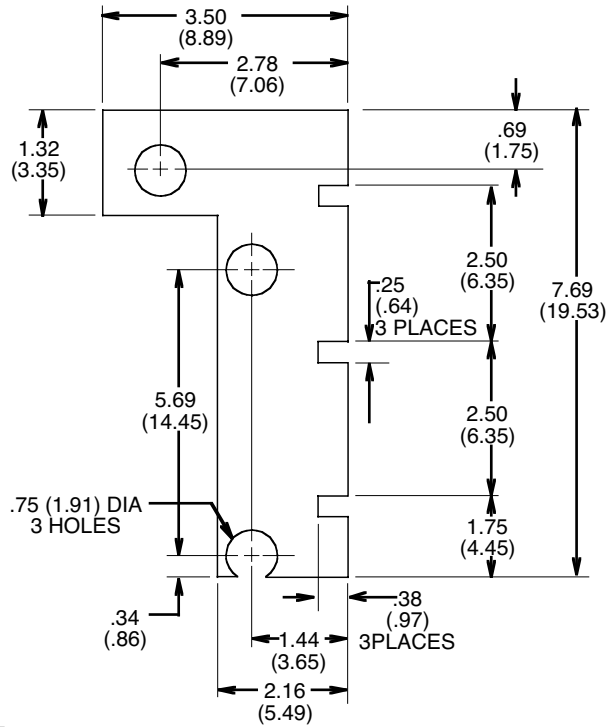

NOTE
1. FABRICATE FROM NSN 5640-00-237-4781 STK

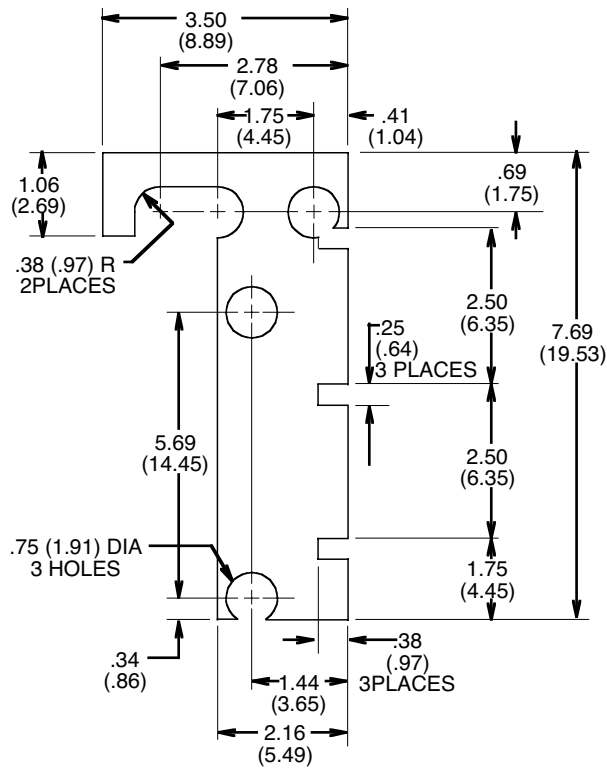

NOTE
1. FABRICATE FROM NSN 5640-00-237-4781 STK

Figures 19 and 20.

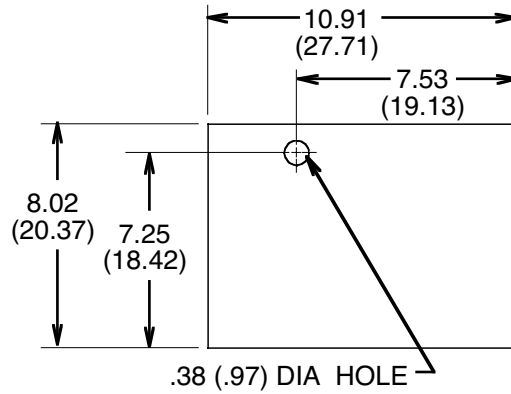

NOTE

1. FABRICATE FROM AMS3570/SH-1/2THK FLEXIBLE POLYURETHANE FOAM, OPEN CELL, MEDIUM FLEXIBILITY, 2.5 LB PER CU FT, .50 (1.27) STK

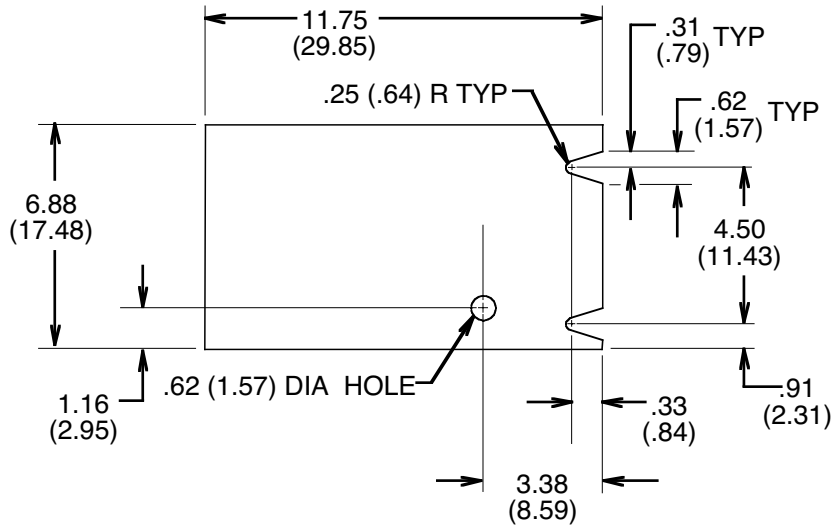

NOTE

1. FABRICATE FROM AMS3570/SH-1/2THK FLEXIBLE POLYURETHANE FOAM, OPEN CELL, MEDIUM FLEXIBILITY, 2.5 LB PER CU FT, .50 (1.27) STK

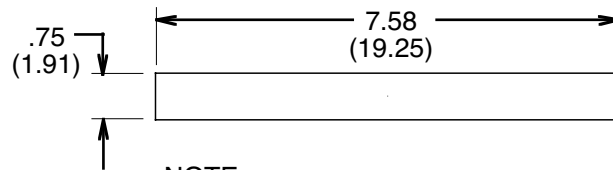

NOTE

1. FABRICATE FROM NSN 5640-00-198-7255 STK

Figures 21, 22, and 23.

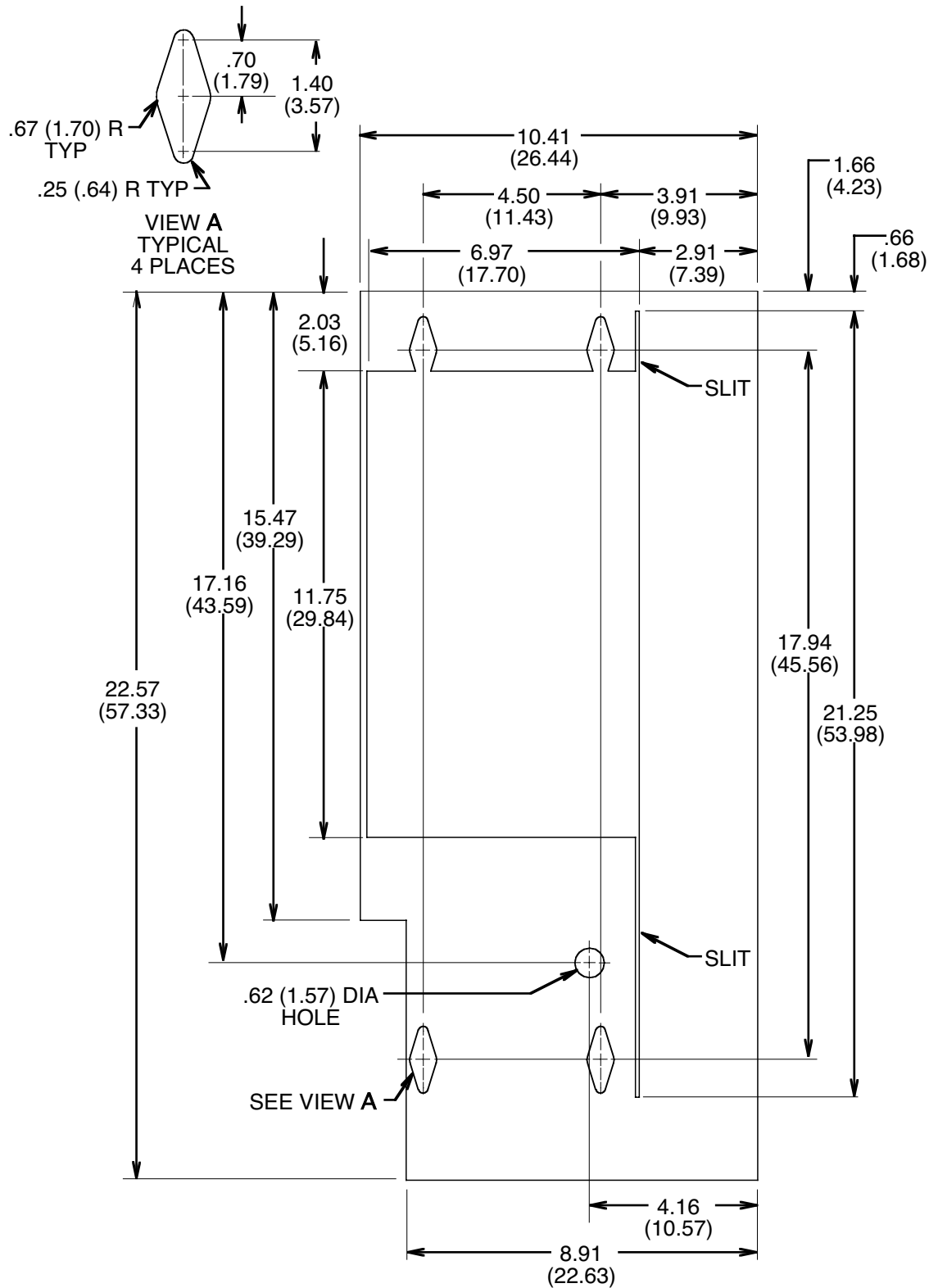

NOTE
 1. FABRICATE FROM AMS3570/SH-1/2THK FLEXIBLE POLYURETHANE FOAM, OPEN CELL, MEDIUM FLEXIBILITY, 2.5 LB PER CU FT, .50 (1.27) STK

Figure 24.

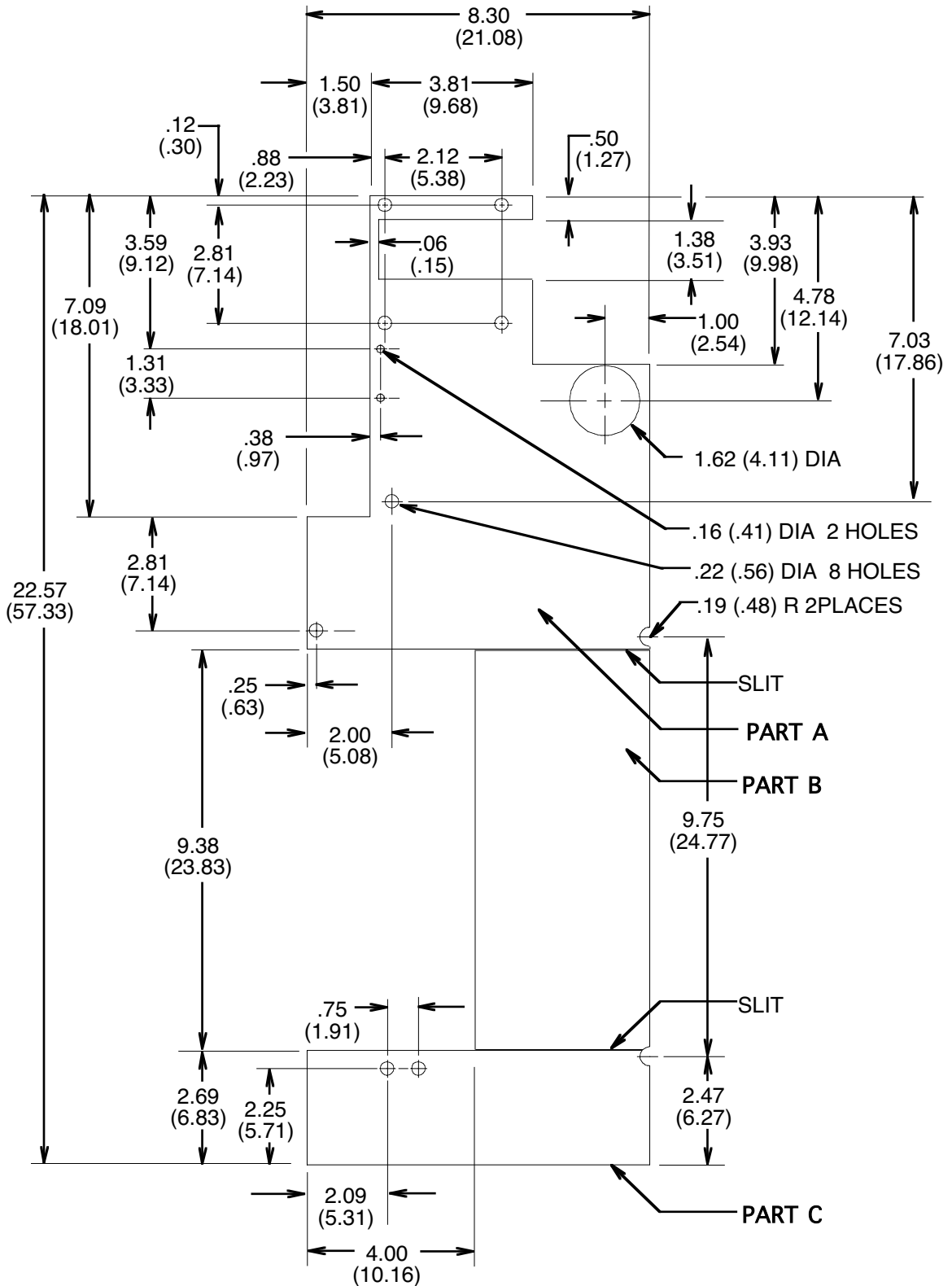

NOTE
 1. FABRICATE FROM AMS3570/SH-1/2THK FLEXIBLE POLYURETHANE FOAM, OPEN CELL, MEDIUM FLEXIBILITY, 2.5 LB PER CU FT, .50 (1.27) STK

Figure 25.

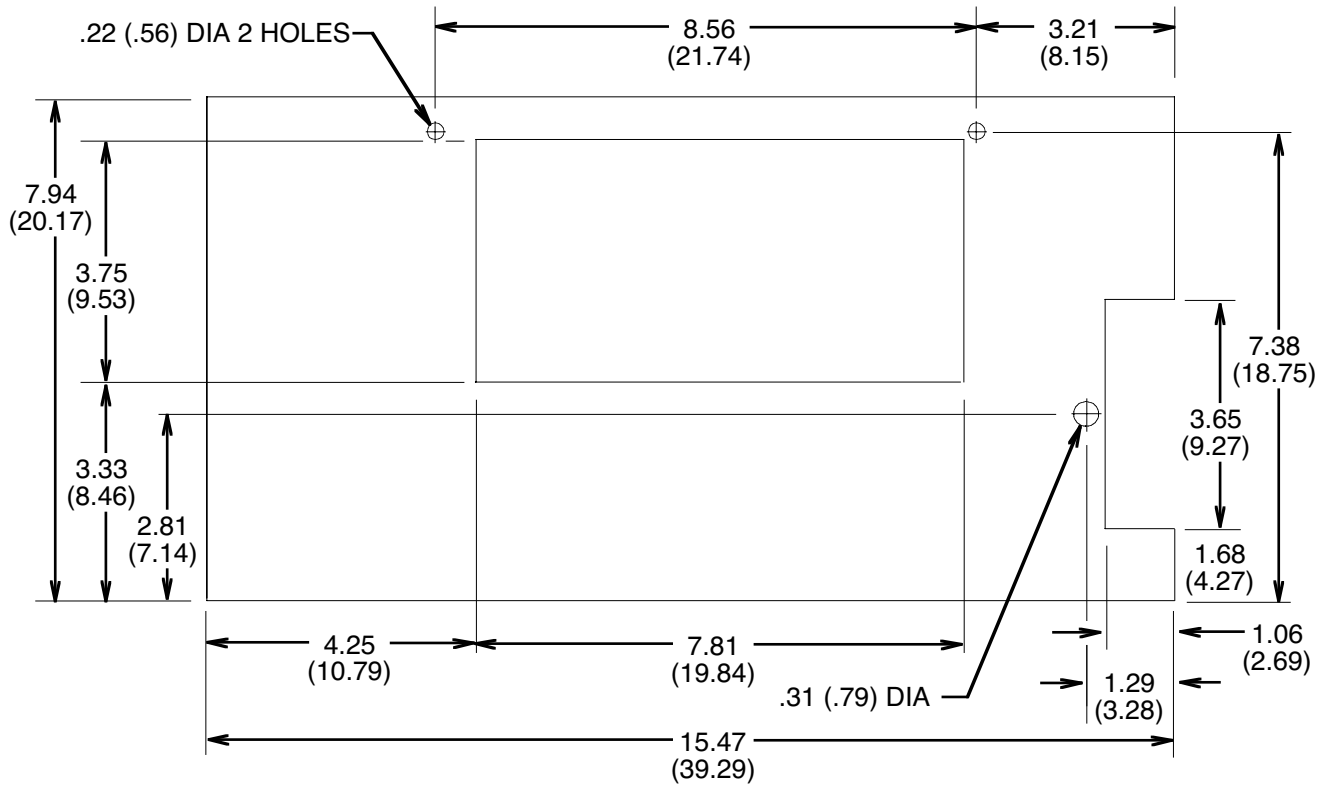

NOTE

1. FABRICATE FROM AMS3570/SH-1/2THK FLEXIBLE POLYURETHANE FOAM, OPEN CELL, MEDIUM FLEXIBILITY, 2.5 LB PER CU FT, .50 (1.27) STK

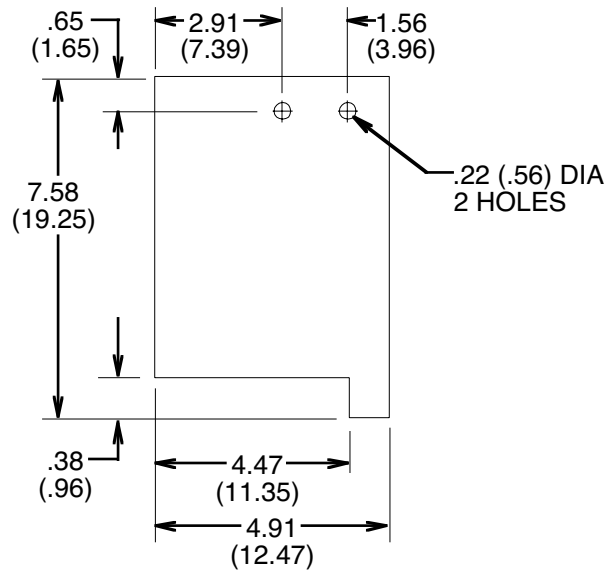

NOTE

1. FABRICATE FROM NSN 5640-00-237-4780 STK

Figures 26 and 27.

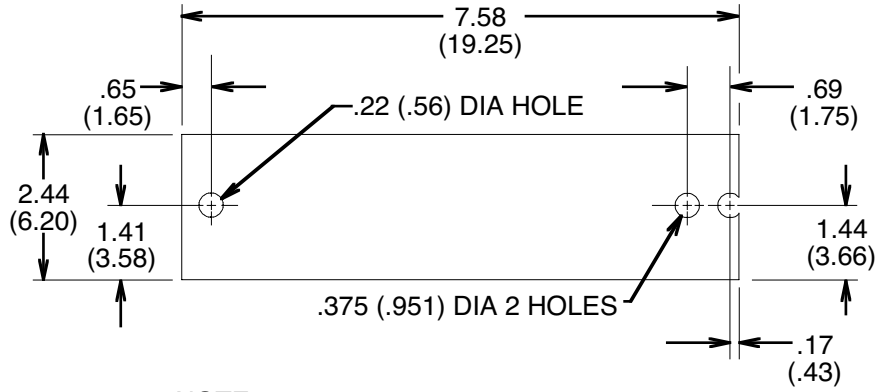

NOTE
1. FABRICATE FROM NSN 5640-00-237-4780 STOCK

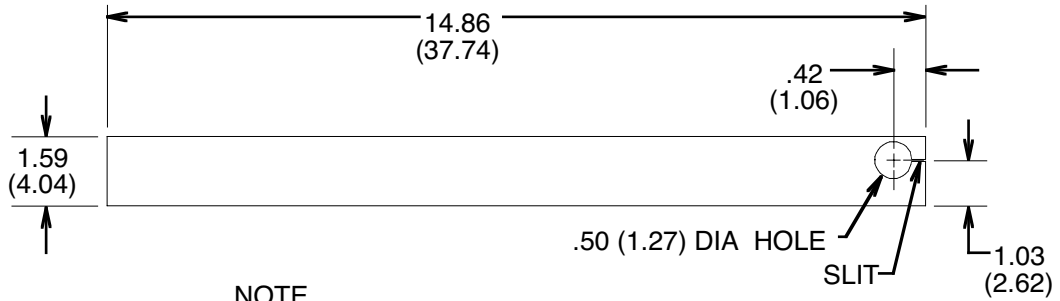

NOTE
1. FABRICATE FROM NSN 5640-00-198-7255 STOCK

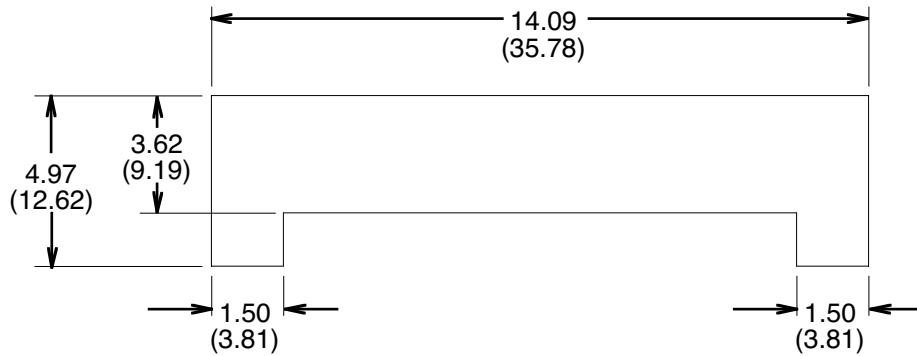

NOTE
1. FABRICATE FROM NSN 5640-00-198-7255 STOCK

Figures 28, 29, and 30.

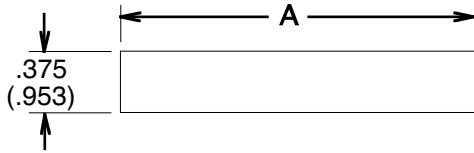

14.09 (35.79)	13225E8451/28
5.34 (13.56)	13225E8451/25
A DIM	PART NUMBER

NOTE
1. FABRICATE FROM 9320-01-N80-1131 STK

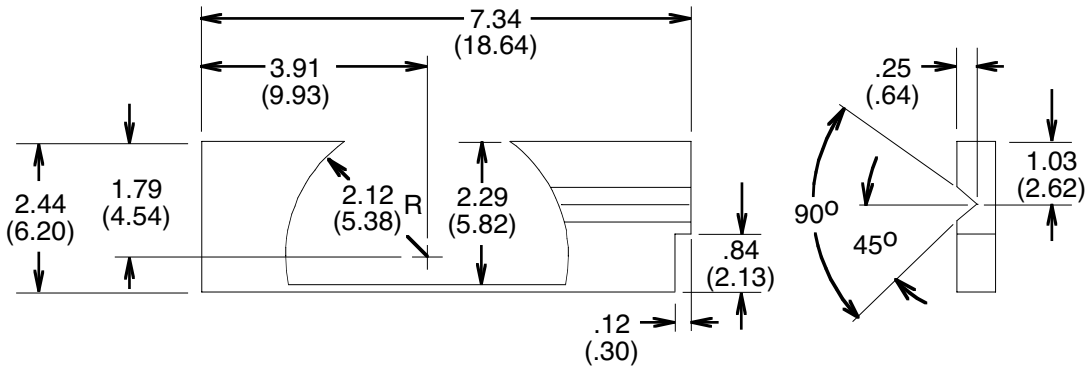

NOTE
1. FABRICATE FROM 5640-00-237-4781 STK

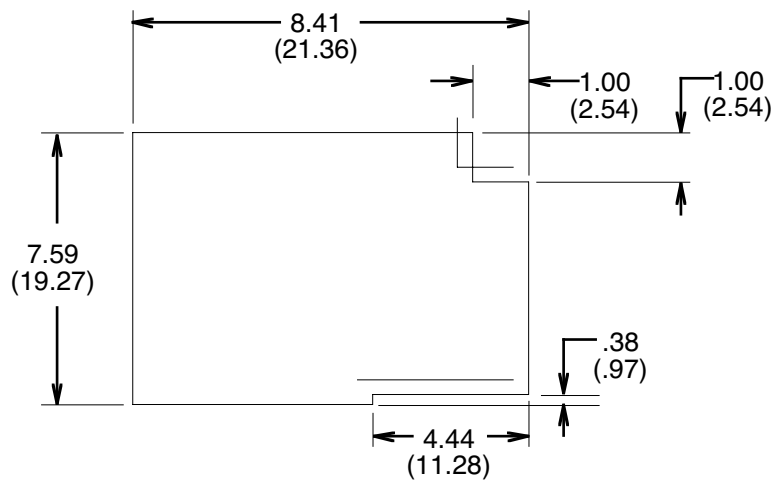

NOTE
1. FABRICATE FROM 5640-00-237-4781 STK

Figures 31, 32, 33.

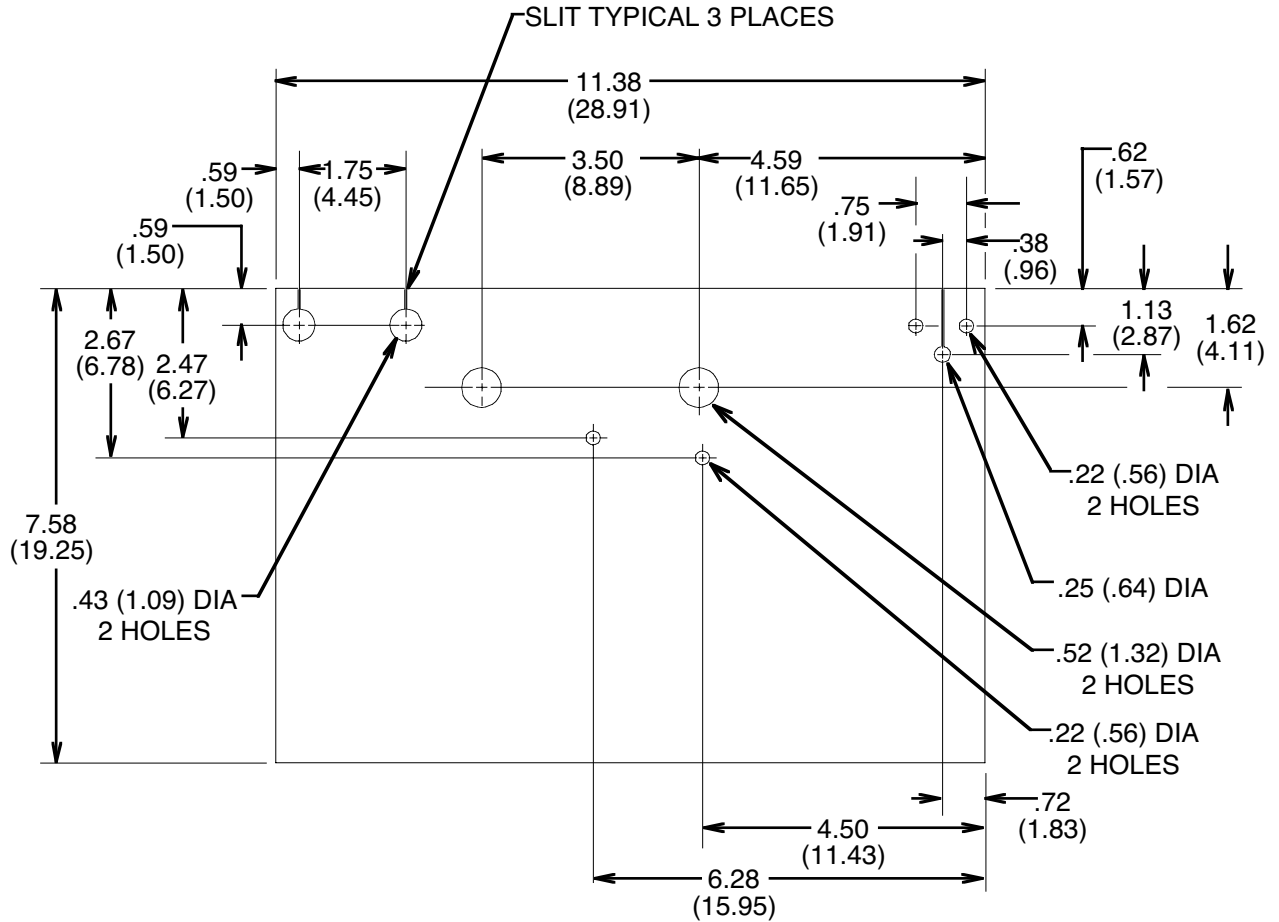

NOTE

1. FABRICATE FROM AMS3570/SH-1/2THK FLEXIBLE POLYURETHANE FOAM, OPEN CELL, MEDIUM FLEXIBILITY, 2.5 LB PER CU FT, .50 (1.27) STK

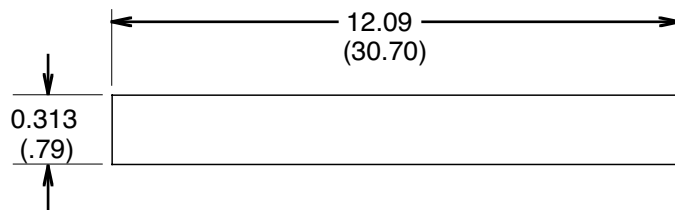

NOTE

1. FABRICATE FROM AMSTMD6576T Y2GRASOFT 0.063 THK X 0.313 WIDE

Figures 34 and 35.

END OF WORK PACKAGE

CHAPTER 11.
SUPPORTING INFORMATION

**OPERATOR'S, UNIT, DIRECT SUPPORT, AND GENERAL SUPPORT MAINTENANCE
AIR CONDITIONER, HORIZONTAL, COMPACT
(NSN 4120-01-502-1319)**

REFERENCES

SCOPE

This section lists all forms, field manuals, and technical manuals referenced in this manual.

FORMS

- Recommended Changes to Publications and Blank Forms
- Equipment Inspection and Maintenance Worksheet
- Quality Deficiency Report

TECHNICAL MANUALS

- Painting Instructions for Field Use
- Unit, Direct Support, and General Support Maintenance Repair Parts and Special Tools List
- Procedures for Destruction of Equipment to Prevent Enemy Use

MISCELLANEOUS PUBLICATIONS

- The Army Maintenance Management System (TAMMS)
- Warranty Program for Air Conditioners
Horizontal, Compact, 9,000, BTU/HR
- Environmental Control of Small Shelters

END OF WORK PACKAGE

OPERATOR'S, UNIT, DIRECT SUPPORT, AND GENERAL SUPPORT MAINTENANCE**AIR CONDITIONER, HORIZONTAL, COMPACT****(NSN 4120-01-502-1319)****INTRODUCTION FOR MAINTENANCE ALLOCATION CHART (MAC)**

INTRODUCTION**The Army Maintenance System MAC**

This introduction provides a general explanation of all maintenance and repair functions authorized at various maintenance levels under the standard Army Maintenance System concept.

The MAC (immediately following the introduction) designates overall authority and responsibility for the performance of maintenance functions on the identified end item or component. The application of the maintenance functions to the end item or component shall be consistent with the capacities and capabilities of the designated maintenance levels, which are shown on the MAC in column (4) as:

Unit — includes two subcolumns, C (operator/crew) and O (unit) maintenance.

Direct Support — includes an F subcolumn.

General Support — includes an H subcolumn.

Depot — includes a D subcolumn.

The tools and test equipment requirements (immediately following the MAC) list the tools and test equipment (both special tools and common tool sets) required for each maintenance function as referenced from the MAC.

The remarks (immediately following the tools and test equipment requirements) contain supplemental instructions and explanatory notes for a particular maintenance function.

Maintenance Functions

Maintenance functions are limited to and defined as follows:

1. **Inspect.** To determine the serviceability of an item by comparing its physical, mechanical, and/or electrical characteristics with established standards through examination (e.g., by sight, sound, or feel). This includes scheduled inspection and gagings and evaluation of cannon tubes.
2. **Test.** To verify serviceability by measuring the mechanical, pneumatic, hydraulic, or electrical characteristics of an item and comparing those characteristics with prescribed standards on a scheduled basis, i.e., load testing of lift devices and hydrostatic testing of pressure hoses.
3. **Service.** Operations required periodically to keep an item in proper operating condition; e.g., to clean (includes decontaminate, when required), to preserve, to drain, to paint, or to replenish fuel, lubricants, chemical fluids, or gases. This includes scheduled exercising and purging of recoil mechanisms.
4. **Adjust.** To maintain or regulate, within prescribed limits, by bringing into proper position, or by setting the operating characteristics to specified parameters.
5. **Align.** To adjust specified variable elements of an item to bring about optimum or desired performance.
6. **Calibrate.** To determine and cause corrections to be made or to be adjusted on instruments of test, measuring, and diagnostic equipment used in precision measurement. Consists of comparisons of two instruments, one of which is a certified standard of known accuracy, to detect and adjust any discrepancy in the accuracy of the instrument being compared.

7. Remove/Install. To remove and install the same item when required to perform service or other maintenance functions. Install may be the act of emplacing, seating, or fixing into position a spare, repair part, or module (component or assembly) in a manner to allow the proper functioning of an equipment or system.
8. Replace. To remove an unserviceable item and install a serviceable counterpart in its place. "Replace" is authorized by the MAC and assigned maintenance level is shown as the third position code of the Source, Maintenance and Recoverability (SMR) code.
9. Repair. The application of maintenance services, including fault location/troubleshooting, removal/installation, disassembly/assembly procedures, and maintenance actions to identify troubles and restore serviceability to an item by correcting specific damage, fault, malfunction, or failure in a part, subassembly, module (component or assembly), end item, or system.

NOTE

The following definitions are applicable to the "repair" maintenance function:

Services — Inspect, test, service, adjust, align, calibrate, and/or replace.

Fault location/troubleshooting — The process of investigating and detecting the cause of equipment malfunctioning; the act of isolating a fault within a system or Unit Under Test (UUT).

Disassembly/assembly — The step-by-step breakdown (taking apart) of a spare/functional group coded item to the level of its least component, that is assigned an SMR code for the level of maintenance under consideration (i.e., identified as maintenance significant).

Actions — Welding, grinding, riveting, straightening, facing, machining, and/or resurfacing.

10. Overhaul. That maintenance effort (service/action) prescribed to restore an item to a completely serviceable/operational condition as required by maintenance standards in appropriate technical publications. Overhaul is normally the highest degree of maintenance performed by the Army. Overhaul does not normally return an item to like new condition.
11. Rebuild. Consists of those services/actions necessary for the restoration of unserviceable equipment to a like new condition in accordance with original manufacturing standards. Rebuild is the highest degree of materiel maintenance applied to Army equipment. The rebuild operation includes the act of returning to zero those age measurements (e.g., hours/miles) considered in classifying Army equipment/components.

Explanation of Columns in the MAC

Column (1) — Group Number. Column (1) lists FGC numbers, the purpose of which is to identify maintenance significant components, assemblies, subassemblies, and modules with the Next Higher Assembly (NHA).

Column (2) — Component/Assembly. Column (2) contains the item names of components, assemblies, subassemblies, and modules for which maintenance is authorized.

Column (3) — Maintenance Function. Column (3) lists the functions to be performed on the item listed in column (2). (For a detailed explanation of these functions refer to "Maintenance Functions" outlined above.)

Column (4) — Maintenance Level. Column (4) specifies each level of maintenance authorized to perform each function listed in column (3), by indicating work time required (expressed as manhours in whole hours or decimals) in the appropriate subcolumn. This work time figure represents the active time required to perform that maintenance function at the indicated level of maintenance. If the number or complexity of the tasks within the listed maintenance function varies at different maintenance levels, appropriate work time figures are to be shown for each level. The work time figure represents the average time required to restore an item (assembly, subassembly, component, module, end item, or system) to a serviceable condition under typical field operating conditions. This time includes preparation time (including any necessary disassembly/assembly time), troubleshooting/fault location time, and quality assurance time in addition to the time required

to perform the specific tasks identified for the maintenance functions authorized in the MAC. The symbol designations for the various maintenance levels are as follows:

C — Operator or crew maintenance

O — Unit maintenance

F — Direct support maintenance

L — Specialized repair activity (SRA)

H — General support maintenance

D — Depot maintenance

NOTE

The "L" maintenance level is not included in column (4) of the MAC. Functions to this level of maintenance are identified by a work time figure in the "H" column of column (4), and an associated reference code is used in the REMARKS column (6). This code is keyed to the remarks and the SRA complete repair application is explained there.

Column (5) — Tools and Equipment Reference Code. Column (5) specifies, by code, those common tool sets (not individual tools), common Test, Measurement and Diagnostic Equipment (TMDE), and special tools, special TMDE and special support equipment required to perform the designated function. Codes are keyed to the entries in the tools and test equipment table.

Column (6) — Remarks Code. When applicable, this column contains a letter code, in alphabetical order, which is keyed to the remarks table entries.

Explanation of Columns in the Tools and Test Equipment Requirements

Column (1) — Tool or Test Equipment Reference Code. The tool or test equipment reference code correlates with a code used in column (5) of the MAC.

Column (2) — Maintenance Level. The lowest level of maintenance authorized to use the tool or test equipment.

Column (3) — Nomenclature. Name or identification of the tool or test equipment.

Column (4) — National Stock Number (NSN). The NSN of the tool or test equipment.

Column (5) — Tool Number. The manufacturer's part number, model number, or type number.

Explanation of Columns in the Remarks

Column (1) — Remarks Code. The code recorded in column (6) of the MAC.

Column (2) — Remarks. This column lists information pertinent to the maintenance function being performed as indicated in the MAC.

OPERATOR'S, UNIT, DIRECT SUPPORT, AND GENERAL SUPPORT MAINTENANCE
AIR CONDITIONER, HORIZONTAL, COMPACT
(NSN 4120-01-502-1319)
MAINTENANCE ALLOCATION CHART (MAC)

Table 1. MAC for F9000H-4SPFI.

(1) GROUP NUMBER	(2) COMPONENT/ASSEMBLY	(3) MAINTENANCE FUNCTION	(4) MAINTENANCE LEVEL				(5) TOOLS AND EQUIPMENT REF CODE	(6) REMARKS CODE	
			UNIT		DIRECT SUPPPORT	GENERAL SUPPORT			DEPOT
			C	O	F	H			D
00	AIR CONDITIONER ASSEMBLY 9,000 BTUH HORIZONTAL, COMPACT, 208 V, 3 PH, 400 HZ	Inspect Adjust Service Replace	0.1 0.1	0.3 0.5 1.0				1 1	a
01	HOUSING COVERS, PANELS GRILLES, SCREENS, AND INFORMATION PLATES	Inspect Adjust Service Repair	0.1 0.1	0.2 0.5		0.5		1 2	b c, d
0101	COVER, ASSEMBLIES	Inspect Repair Replace	0.1		0.5			2 1	c
0102	LOUVER, ASSEMBLY	Inspect Adjust Service Repair Replace	0.1	0.2 0.5 0.2 1.0 1.0				1 1 1 1	d
02	AIR CIRCULATING AND CONDENSATE DRAIN SYSTEM	Inspect Service Repair	0.1	0.2 0.3 0.5				1 1 1	d
03	ELECTRICAL	Inspect Test Repair		1.0 1.0 1.5				1 1 1, 4	d
0301	CONTROL MODULE ASSEMBLY	Test Repair Replace		1.0 1.0 0.5				1 1 1	d
030101	CONNECTOR WITH LEADS	Test Repair Replace		0.5 1.0 1.5				1 1 1	
0302	JUNCTION BOX ASSEMBLY	Test Repair Replace		1.0 1.0 3.0				1, 3 1 1	d
030201	WIRING HARNESS	Test Repair Replace		0.5 1.0 1.5				1 1 1	
0303	CABLE ASSEMBLIES	Test Repair Replace		0.5 1.0 1.5				1 1 1	
0304	POWER FACTOR IMPROVEMENT ASSEMBLY	Test Repair Replace		0.5 1.0 1.5				1 1 1	d
04	EVAPORATOR FAN, MOTOR, AND HEATER	Inspect Test Repair		0.5 1.0 4.0				1 1 1	d

(1) GROUP NUMBER	(2) COMPONENT/ASSEMBLY	(3) MAINTENANCE FUNCTION	(4) MAINTENANCE LEVEL					(5) TOOLS AND EQUIPMENT REF CODE	(6) REMARKS CODE
			UNIT		DIRECT SUPPPORT	GENERAL SUPPORT	DEPOT		
			C	O	F	H	D		
0401	EVAPORATOR FAN ASSY, 208 V, 3 PH, 400 HZ	Inspect Service Test Repair Replace		0.5 0.5 0.5 1.0 1.5				1 1 1 1 1	e d
05	CONDENSER FAN & MOTOR	Inspect Service Test Repair Replace		0.5 0.5 0.5 1.0 1.5	0.5 0.5 6.0 5.5			1 1 1 1, 5, 6, 7 1, 5, 6, 7	e d h
06	REFRIGERATION SYSTEM	Inspect Test Repair			1.0 1.5 6.0			1 1 1, 5, 6, 7	
0601	VALVES, SOLENOID	Test Repair Replace		0.5 0.8	0.8 6.0			1, 3 1 1, 5, 6, 7	f
0602	COMPRESSOR	Test Repair Replace		0.5 0.8	0.8 6.0			1 1 1, 5, 6, 7	g
07	HOUSING	Inspect Repair Replace				1.0 4.0 8.0		1 2 1, 5, 6, 7	
08	ACCESSORY ITEMS	Inspect Replace		0.1 0.5				1 1	

Table 2. Tools and Test Equipment for F9000H-4SPFI.

TOOL OR TEST EQUIPMENT REF CODE	MAINTENANCE LEVEL	NOMENCLATURE	NATIONAL STOCK NUMBER	TOOL NUMBER
1	O	Tool Kit, Service, Refrigeration Unit	5180-00-597-1474	SC 5180-90-CL-N18
2	F	Shop Equipment, Auto Organizational #1 Common	4910-00-754-0654	
3	O	Power Supply, 28 Volt dc	6130-01-143-5947	
4	O	Heat Gun	4940-01-042-4855	
5	F	Recovery and Recycle Unit, Refrigerant	4130-01-338-2707	
6	F	Nitrogen Regulator	6680-00-503-1327	
7	F	Pump, Vacuum	4310-00-289-5967	

Table 3. Remarks for F9000H-4SPFI.

REMARKS CODE	REMARKS
a	Operator is limited to adjustment of control panel settings.
b	Operator is limited to adjustment of air discharge and return louvers on front of unit.
c	Repair is limited to straightening of bends or dents and replacement of gaskets, insulation or nameplates.
d	Repair is limited to replacement of damaged component parts.
e	Service is limited to cleaning of fan blades.
f	Repair to solenoid valves at "O" level is limited to electrical coil.
g	Compressor repair is limited to electrical connector.
h	Repair and replacement at "O" level is limited to fan motor and shaft extension only. Condenser coil must be removed to repair or replace the fan or housing.

OPERATOR'S, UNIT, DIRECT SUPPORT, AND GENERAL SUPPORT MAINTENANCE**AIR CONDITIONER, HORIZONTAL, COMPACT****(NSN 4120-01-502-1319)****COMPONENTS OF END ITEM (COEI) AND BASIC ISSUE ITEMS (BII) LISTS**

INTRODUCTION**Scope**

This section lists components of the end items and basic issue items for the air conditioner to help you inventory the items required for safe and efficient operation.

General

The COEI and BII information is divided into the following lists:

1. Components of End Item (COEI). This list is for information purposes only and is not authority to requisition replacements. These items are part of the end item. As part of the end item, these items must be with the end item whenever it is issued or transferred between property accounts. Items of COEI are removed and separately packaged for transportation or shipment only when necessary. Illustrations are furnished to help you find and identify the items.
2. Basic Issue Items (BII). These essential items are required to place the (*enter name of end item*) in operation, operate it, and to do emergency repairs. Although shipped separately packaged, BII must be with the air conditioner during operation and when it is transferred between property accounts. Listing these items is your authority to request/requisition them for replacement based on authorization of the end item by the TOE/MTOE. Illustrations are furnished to help you find and identify the items.

Explanation of Columns in the COEI List and Basic Issue Items (BII) List

The following list provides an explanation of columns found in the tabular listings:

1. Column (1) — Illus Number. Gives you the number of the item illustrated.
2. Column (2) — National Stock Number (NSN). Identifies the stock number of the item to be used for requisitioning purposes.
3. Column (3) — Description, CAGEC, and Part Number. Identifies the Federal item name (in all capital letters) followed by a minimum description when needed. The stowage location of COEI and BII is also included in this column. The last line below the description is the CAGEC (commercial and Government entity code) followed by the part number.
4. Column (4) — Usable On Code. When applicable, gives you a code if the item you need is not the same for different models of equipment.

These codes are identified below:

Column (5) — Unit of Measure (U/M). Indicates the physical measurement or count of the item as issued per the National Stock Number shown in column (2).

Column (6) — Qty Required. Indicates the quantity required.

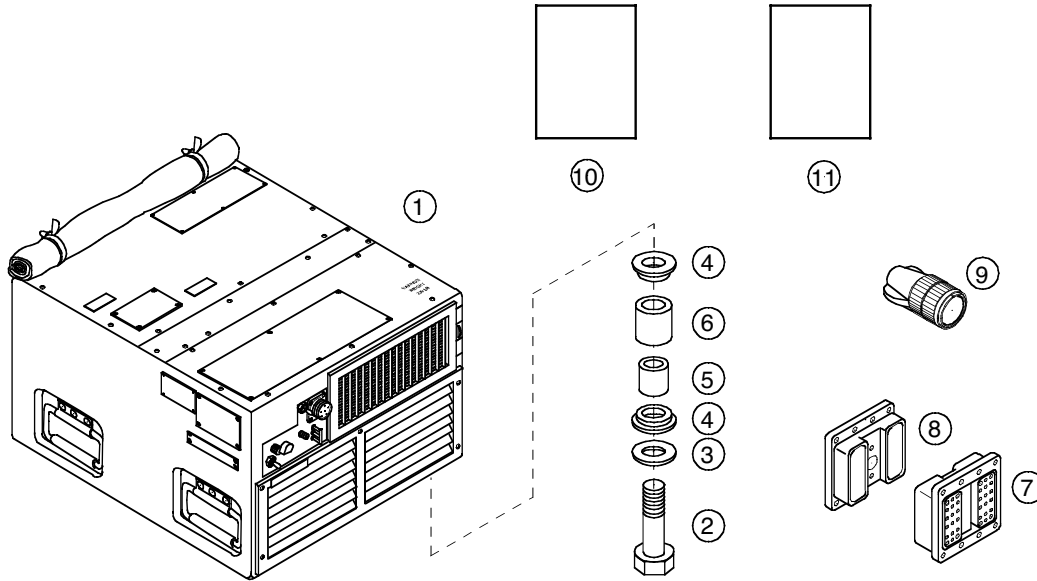

Table 1. Components of End Item and Basic Issue Items List.

(1) ILLUS NUMBER	(2) NATIONAL STOCK NUMBER	(3) DESCRIPTION, CAGEC, AND PART NUMBER	(4) USABLE ON CODE	(5) U/M	(6) QTY RQR
1	4120-01-502-1319	Air Conditioner (94833) F9000H-4SPFI		EA	1
2	5305-00-269-2807	Screw, Cap, Hex Head (96906) MS90726-64		EA	4
3	5310-00-566-9504	Washer (97403) 13216E6138-2		EA	4
4	5340-01-042-5759	Mount Resilient (97403) 13216E6137		EA	8
5	5365-01-044-6408	Spacer (97403) 13216E6152		EA	4
6	4720-01-038-2334	Tube Elastomeric (97403) 13216E6153		EA	4
7	5935-00-482-2390	Connector, Receptacle Electrical (97403) 13216E6177		EA	1
8	5935-00-482-2388	Connector, Plug Electrical (97403) 13216E6209-1		EA	1
9	5935-00-725-4153	Connector, Plug Electrical (96906) MS3106R18-11S		EA	1
10		Department of the Army Technical Manual; Operator's, Unit, Direct Support, and General Support Maintenance Manual TM9-4120-428-14		EA	1
11		Department of the Army Technical Manual; Unit, Direct Support, and General Support Repair Parts and Special Tools List Manual TM9-4120-428-24P		EA	1

END OF WORK PACKAGE

OPERATOR'S, UNIT, DIRECT SUPPORT, AND GENERAL SUPPORT MAINTENANCE
AIR CONDITIONER, HORIZONTAL, COMPACT
(NSN 4120-01-502-1319)
EXPENDABLE AND DURABLE SUPPLIES AND MATERIALS LIST

INTRODUCTION

Scope

This section lists the expendable/durable supplies and materials you will need to operate and maintain the air conditioner. These items are authorized to you by CTA 50-970, Expendable Items (Except Medical, Class V, Repair Parts, and Heraldic Items).

Explanation of Columns in the Expendable/Durable Items List

Column (1) — Item Number. This number is assigned to the entry in the list and is referenced in the narrative instructions to identify the material (e.g., Use coater air filter, Item 1, WP 0094 00).

Column (2) — Level. This column identifies the lowest level of maintenance that requires the listed item (*include as applicable: C = Operator/Crew, O = Unit/AVUM, F = Direct Support/AVIM, H = General Support, D = Depot*).

Column (3) — National Stock Number (NSN). This is the NSN assigned to the item, used to request or requisition the item.

Column (4) — Item Name, Description, Commercial and Government Entity Code (CAGEC), and Part Number (P/N). This column provides the Federal Item Name and, if required, a description to identify the item. The last line for each item indicates the part number followed by the Commercial and Government Entity (CAGE) in parenthesis, if applicable.

Column (5) — Unit of Measure (U/M). This code shows the physical measurement or count of an item, such as gallon, dozen, gross, etc.

Table 4. Expendable and Materials Items List.

(1) ITEM NUMBER	(2) LEVEL	(3) NATIONAL STOCK NUMBER	(4) ITEM NAME, DESCRIPTION, CAGEC, AND PART NUMBER	(5) U/M
1	O	4130-00-860-0042	Coater, Air Filter, 1 Pint Container	Ea.
2	F	3040-00-664-0439	Adhesive, General Purpose, 1 Pint Container	Ea
3	O	6850-00-281-1985	Dry Cleaning Solvent (58536) A-A-511	Gal.
4	F	6850-00-837-9927	Monochlorodifluoromethane, Tehnical: w/cylinder 22 IB (Refrigerant-22) (81348) BB-F-1421, Type 22	Cy
5	F	6830-00-782-6512	Dischlorotetrafluoroethane Technical: w/cylinder (Refrigerant- 1 14) BB-F-1421, Type 114 (81348)	Cy
6	O	3439-01-045-7940	Flux, Solder, Liquid, Rosin Base MIL-F-14256	Qt
7	O		Solder, Lead-Tin, QQ-S-571 Type SN60WRP2	
8	F	6830-00-292-0732	Nitrogen	Cy

(1) ITEM NUMBER	(2) LEVEL	(3) NATIONAL STOCK NUMBER	(4) ITEM NAME, DESCRIPTION, CAGEC, AND PART NUMBER	(5) U/M
9	F		Brazing Alloy, Silver QQ-B-564, Grade O, 1, or II	Oz
10	F		Brazing Alloy, Silver Grade III	Oz
11	F	3439-00-640-3713	Flux, Brazing O-F-499, Type B	Oz
12	F	5350-00-192-5047	Abrasive cloth	Pg
13	F	7920-00-205-1711	Rags	Pg
14	O	9150-01-340-3804	Silicon Spray, P/N AS193 (61014)	Oz
15	O	7930-00-764-5066	Detergent, Dishwasher	Oz
16	O	6510-01-016-8772	Adhesive Remover	Oz
17	F	9150-00-189-6727	Oil, MIL-L-2104, Grade 10 (81349)	Qt
18	F	5640-00-580-6276	Insulation Tape	Roll

END OF WORK PACKAGE

GLOSSARY

Term	Definition
ECU	Environmental Control Unit
ESD	Electro-Static Discharge
BTU	British Thermal Unit

INDEX

<u>WP Title</u>	<u>WP Sequence No.</u>	<u>WP Title</u>	<u>WP Sequence No.</u>
A		And Installation	
Actuating Cylinder Replacement	0077 00	Control Module Wiring Harness Inspection, Removal, Testing, Repair, And Installation	0032 00
B		D	
Brazing, Debrazing, And Cleaning Procedures	0062 00	Dehydrator (Filter/Drier) Replacement	0070 00
C		Description And Use Of Operator Controls And Indicators	0004 00
Charging The Refrigeration System	0066 00	Discharging The Refrigerant System	0060 00
Components Of End Item (COEI) And Basic Issue Items (BII) Lists	0093 00	E	
Compressor Circuit Breaker (CB1) Removal, Inspection, Testing, Replacement, And Installation	0030 00	Electrical Wiring Repair	0025 00
Compressor Testing, Removal, Repair, And Installation	0085 00	Equipment Description And Data	0002 00
Condensate Drain Inspection, Cleaning, And Replacement	0024 00	Evacuating The Refrigeration System	0065 00
Condenser Air Discharge Louver And Linkage Cleaning, Inspection, Removal And Installation	0022 00	Evaporator Coil Inspection And Cleaning	0048 00
Condenser Coil Inspection And Cleaning	0051 00	Evaporator Coil Replacement	0071 00
Condenser Coil Replacement	0082 00	Evaporator Fan Speed Toggle Switch (S2) Removal, Inspection, Testing, Replacement, And Installation	0028 00
Condenser Fan And Housing Removal And Installation	0057 00	Evaporator Fan, Motor, And Housing Cleaning, Inspection, Testing, Removal, Assembly, And Installation	0044 00
Condenser Fan Motor, Inspection, Testing, Removal, And Installation	0047 00	Expansion Valve (Primary) Replacement	0072 00
Connectors (Installation)	0052 00	Expansion Valve (Quench)	0073 00
Control Circuit Breaker CB2 Inspection, Testing, And Replacement	0039 00	Expendable And Durable Supplies And Materials List	0094 00
Control Module Assembly Removal, Repair And Installation	0026 00		
Control Module Rotary Switch Relay Inspection, Removal, Testing, Repair, Replacement,	0031 00		

<u>WP Title</u>	<u>WP Sequence No.</u>	<u>WP Title</u>	<u>WP Sequence No.</u>
F		J	
Fabric Cover Removal, Cleaning And Installation	0015 00	Junction Box Removal, Inspection, Repair, And Installation	0033 00
Flushing The Refrigerant System	0063 00	Junction Box Wiring Harness Inspection, Removal, Testing, Repair, And Installation	0034 00
Fresh Air Damper And Actuator Cleaning And Inspection	0023 00		
Fresh Air Damper And Actuator Removal, Replacement, Installation, And Adjustment	0056 00	L	
		Leak Testing	0064 00
G		Liquid Indicator (Sight Glass) Replacement	0083 00
General Information	0001 00	Low Pressure Cutout Switch (LPCO) Bypass Installation	0050 00
General Information	0087 00	Low Pressure Switch (S5) Inspection, Testing, And Replacement	0079 00
General Maintenance Instructions	0054 00	Lubrication Instructions	0012 00
H		M	
Heater Elements Inspection, Testing, Removal, Cleaning, Replacement, And Installation	0046 00	Maintenance Allocation Chart (Mac)	0092 00
Heater Thermostat S6 Removal, Inspection, Testing, Replacement, And Installation	0045 00	Maintenance Items (Various)	0011 00
High Pressure Switch S4 Inspection, Testing, And Replacement	0078 00	Miscellaneous Cables, Harnesses, And Terminal Boards Inspection, Testing, Repair, And Installation	0040 00
Housing Repair And Replacement	0088 00	Mist Eliminator Replacement, Cleaning, And Inspection	0021 00
I		Mode Selector Switch S1 Removal, Inspection, Testing, Replacement, And Installation	0029 00
Illustrated List Of Manufactured Items	0089 00	O	
Information Plates Inspection And Replacement	0020 00	Operation Under Unusual Conditions	0006 00
Installation Hardware Inspection And Replacement	0053 00	Operation Under Usual Conditions	0005 00
Introduction For Maintenance Allocation Chart (Mac)	0091 00	Overheating Checks	0068 00

<u>WP Title</u>	<u>WP Sequence No.</u>	<u>WP Title</u>	<u>WP Sequence No.</u>
P		S	
Phase Sequence Relay (K5) Testing And Replacement	0036 00	Screens, Guards, And Louvers Repair And Replacement	0058 00
Power Factor Improvement Assembly Testing, Removal, And Installation	0043 00	Service (Charging) Valves Replacement	0080 00
Pressure Regulator Replacement	0076 00	Service Manifold Removal And Installation	0059 00
Pressure Relief Valve Replacement	0081 00	Service Upon Receipt	0013 00
Preventative Maintenance Checks And Services (PMCS)	0010 00	Solenoid Valve (Coil) Testing, Repair, Removal, And Installation	0049 00
Preventive Maintenance Checks And Services	0014 00	Solenoid Valve L1 Replacement	0074 00
Purging The Refrigerant System	0061 00	Solenoid Valve L2 Replacement	0075 00
R		Supply Air Louver Removal, Cleaning And Installation	0019 00
Rear Screen And Guard Cleaning And Replacement	0017 00	T	
Receiver Replacement	0084 00	Temperature Selector Switch S3 Removal, Inspection, Testing, And Installation	0027 00
Rectifier CR1 And Capacitors C1 And C2 Inspection, Testing, And Replacement	0041 00	Theory Of Operation, Cooling And Heating	0003 00
References	0090 00	Time Delay Relay (K1) Testing, Inspection, Removal, And Installation	0035 00
Refrigerant Pressure Check	0069 00	Top Panel Removal, Cleaning And Installation	0016 00
Refrigeration System Troubleshooting	0067 00	Top Panels Repair And Replacement	0055 00
Relay K4 Inspection, Testing, And Replacement	0038 00	Transformer T1 Inspection And Replacement	0042 00
Relays K2 And K3 Inspection, Testing, And Replacement	0037 00	Troubleshooting Index And Operational Checkout And Troubleshooting Procedures	0007 00
Return Air Louver And Air Filter Removal, Cleaning, Inspection, And Installation	0018 00	Troubleshooting Index And Operational Checkout And Troubleshooting Procedures	0008 00
		Troubleshooting Index And Operational Checkout And Troubleshooting Procedures	0009 00
		Tubing And Fitting Replacement	0086 00

RECOMMENDED CHANGES TO PUBLICATIONS AND BLANK FORMS						Use Part II (<i>reverse</i>) for Repair Parts and Special Tool Lists (RPSTL) and Supply Catalogs/Supply Manuals (SC/SM).	DATE
For use of this form, see AR 25-30; the proponent agency is OAASA							
TO: (<i>Forward to proponent of publication or form</i>) (<i>Include ZIP Code</i>)				FROM: (<i>Activity and location</i>) (<i>Include ZIP Code</i>)			
PART I - ALL PUBLICATIONS (EXCEPT RPSTL AND SC/SM) AND BLANK FORMS							
PUBLICATION/FORM NUMBER					DATE		TITLE
ITEM	PAGE	PARA- GRAPH	LINE	FIGURE NO.	TABLE	RECOMMENDED CHANGES AND REASON	
* Reference to line numbers within the paragraph or subparagraph.							
TYPED NAME, GRADE OR TITLE					TELEPHONE EXCHANGE/AUTOVON, PLUS EXTENSION		SIGNATURE

TO: <i>(Forward direct to addressee listed in publication)</i>	FROM: <i>(Activity and location) (Include ZIP Code)</i>	DATE
---	--	-------------

PART II - REPAIR PARTS AND SPECIAL TOOL LISTS AND SUPPLY CATALOGS/SUPPLY MANUALS

PUBLICATION NUMBER			DATE		TITLE			
PAGE NO.	COLM NO.	LINE NO.	NATIONAL STOCK NUMBER	REFERENCE NO.	FIGURE NO.	ITEM NO.	TOTAL NO. OF MAJOR ITEMS SUPPORTED	RECOMMENDED ACTION

PART III - REMARKS *(Any general remarks or recommendations, or suggestions for improvement of publications and blank forms. Additional blank sheets may be used if more space is needed.)*

TYPED NAME, GRADE OR TITLE	TELEPHONE EXCHANGE/AUTOVON, PLUS EXTENSION	SIGNATURE
----------------------------	--	-----------